

Kubota

Kubota HP: <https://www.kubota.com/network/index.html>

English (U.S.A./CANADA)
Code No. RD188-8121-1

K
X
0
4
0
-
5

OPERATOR'S MANUAL

KUBOTA EXCAVATOR

MODEL **KX**040-5

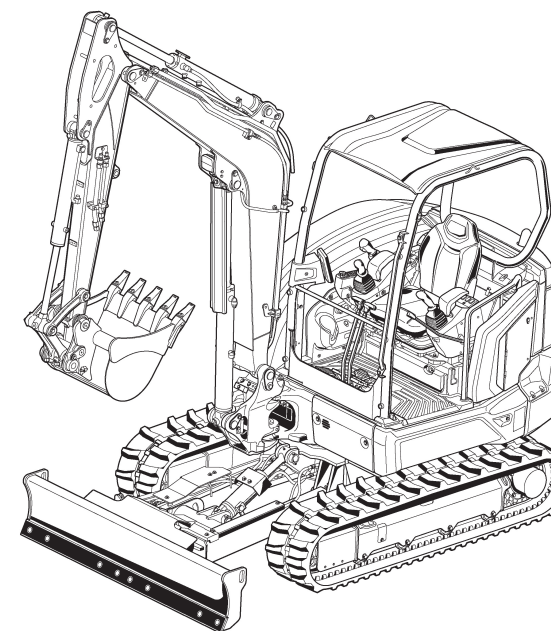

1WRRR00001A01

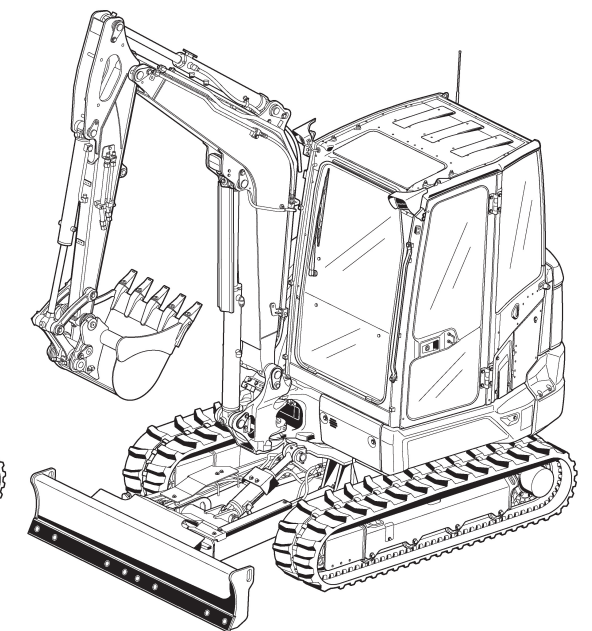

1WRRR00002A01

READ AND SAVE THIS MANUAL

LIST OF ABBREVIATION

Abbreviations	Description
AFS	Air Flow Sensor
AI	Auto Idle
API	American Petroleum Institute
ASTM	American Society for Testing and Materials, USA
CECE	Committee for European Construction Equipment
CRS	Common Rail System
DIN	Deutsches Institut für Normung, GERMANY (German Institute for Standardization)
DOC	Diesel Oxidation Catalyst
DPF	Diesel Particulate Filter
EGR	Exhaust Gas Re-circulation
EN	European Standard
FRONT	"Front" means the direction towards the boom and dozer
Hi	High speed
ISO	International Organization for Standardization
JIS	Japanese Industry Standard
L	Volume (Liter)
L/min	Liter per minute
Lo	Low speed
MAF	Mass Air Flow
MIL	Military Standard
OPG	Operator Protective Guards
OSHA	Occupational Safety and Health Administration
P/L	Pressure Limiter
PCV	Positive Crankcase Ventilation
ROPS	Roll-Over Protective Structure
rpm	Revolutions Per Minute
SAE	Society of Automotive Engineers, USA
TPSS	Two Pattern Selection System

California Proposition 65









































▲ WARNING ▲

Engine exhaust, some of its constituents, certain vehicle components and fluids, contain or emit chemicals known to the State of California to cause cancer and birth defects or other reproductive harm.

**Canadian Electromagnetic Compatibility (EMC):
This machine complies with Industry Canada ICES-002.**

UNIVERSAL SYMBOLS

The instruments and operation elements have been marked with a series of symbols in order to simplify the operation of the machine. These symbols are listed below with their respective descriptions.

	Safety alert symbol		Swivel - right
	Warning lamp - "Fuel level too low"		Boom - up
	System lamp		Boom - down
	Warning lamp - "Engine oil pressure"		Arm - up
	Warning lamp - "Battery charge"		Arm - crowd
	Coolant temperature		Bucket - crowd
	Hydraulic oil temperature		Bucket - dump
	Auto Idle (AI)		Boom - swing (left)
	Indicator lamp - "Glow"		Boom - swing (right)
	Working light		Dozer - raise
	Horn		Dozer - lower
	Wiper		Dozer float
	Washer and wiper		Operation direction of control lever
	Diesel		Operation direction of control lever
	Hydraulic fluid		Read operator's manual
	Gear oil		Lock
	Fast		Unlock
	Slow		Engine stop
	Machine - overhead movement toward the front		DPF standby / regeneration
	Machine - overhead movement toward the rear		Engine rev up
	Swivel - left		



Inhibit DPF regeneration



Service indicator



Menu switch



Return switch



Travel alarm cancel



Camera



Auxiliary port



Auxiliary port - one-way hold



Acknowledge



Cancel



Air conditioner

FOREWORD

Thank you for the purchase of a Kubota product.

Before using this product, read this manual carefully and use the product correctly. After reading, keep the manual in a safe and easy-to-access place for future reference. Note that product specifications are subject to change without prior notice. The product delivered to you may differ slightly from the product described in the manual.



SAFETY FIRST

This symbol, the industry's "Safety Alert Symbol", is used throughout this manual and on labels on the machine itself to warn of the possibility of personal injury. Read these instructions carefully. It is essential that you read the instructions and safety regulations before you attempt to assemble or use this unit.



DANGER:

Indicates an imminently hazardous situation which, if not avoided, will result in death or serious injury.



WARNING:

Indicates a potentially hazardous situation which, if not avoided, could result in death or serious injury.



CAUTION:

Indicates a potentially hazardous situation which, if not avoided, could result in minor or moderate injury.

IMPORTANT:

Indicates that equipment or property damage could result if instructions are not followed.

NOTE:

Gives helpful information.

OTHERS

ABOUT TRADEMARKS

Trademark	Owner
 Bluetooth [®]	The Bluetooth [®] word mark and logos are registered trademarks owned by Bluetooth SIG, Inc. and any use of such marks by Kubota Corporation is under license.

Company names, product names and service names described in this manual are the trademarks or registered trademarks of their respective owners. In the text, those names are not accompanied by trademark symbols (®, ™).

CONTENTS

SAFE OPERATION	7
DEALER SERVICE	31
WARRANTY POLICY	31
SCRAPPING THE PRODUCT AND ITS PROCEDURE.....	32
TECHNICAL DATA	33
EXCAVATOR PARTS	35
INSTRUMENT PANEL AND CONTROLS	37
INSTRUMENT PANEL AND SWITCHES	37
HANDLING THE INSTRUMENT PANEL AND SWITCHES.....	40
1. Starter switch.....	40
2. Display for normal operation.....	40
2.1 Fuel gauge	40
2.2 Fuel level audible indication switch (when refueling).....	41
2.3 Coolant temperature gauge	41
2.4 Overheat warning.....	42
2.5 Hydraulic oil temperature gauge	42
2.6 Hydraulic oil overheat warning	42
2.7 Temperature drop indication of hydraulic oil.....	43
2.8 Hour meter	43
2.9 Engine tachometer	43
2.10 Glow indication.....	43
2.11 Periodic Check	43
2.11.1 Service hour meter.....	45
2.12 Log record	46
2.13 AUX settings	46
2.14 User settings	46
2.14.1 Setting the clock	46
2.14.2 Reordering year/month/day and selecting AM/PM or 24-hour.....	48
2.14.3 Setting the display brightness.....	48
2.14.4 Setting the engine auto-stop function	49
2.14.5 Setting the work light turn-off delay function.....	50
2.14.6 Registering new user passwords.....	50
2.14.7 Changing user passwords	51
2.14.8 Deleting user passwords	52
2.14.9 Changing the machine password	53
2.14.10 Setting the heat-up function.....	53
2.15 Audio mode	54
2.15.1 Changing the audio screen.....	54
2.15.2 Switching the audio power ON and OFF	55
2.15.3 Switching audio source.....	56
2.15.4 Adjusting the audio volume.....	56
2.15.5 Operating AM mode.....	57
2.15.6 Operating FM mode.....	58
2.15.7 Operating Bluetooth mode.....	59
2.15.8 Operating weather band mode	60
2.15.9 Call control for Bluetooth-connected cell phone	62
3. Warning lamp.....	63
4. Display for warnings	63
4.1 Remaining fuel warning.....	63
4.2 Battery charge warning	63
4.3 Low engine oil pressure warning.....	63

4.4 Various error warnings	64
4.5 Checking error warnings	64
HORN SWITCH	64
OPERATING THE WORKING LIGHT SWITCH.....	64
1. Night operation	65
AUX PORT ENABLE SWITCH	65
AUTO IDLE CONTROL SWITCH	65
THROTTLE POTENTIOMETER	66
TRAVEL SPEED SWITCH	66
INHIBIT DIESEL PARTICULATE FILTER (DPF) REGENERATION SWITCH.....	67
BEACON LIGHT SWITCH	67
ELECTRICAL OUTLET AND USB OUTLET.....	67
CONTROL PEDALS AND LEVERS	69
HANDLING THE PILOT CONTROL LOCK LEVER.....	70
CAB OPERATION.....	71
OPERATING THE WIPER AND WASHER.....	71
INTERIOR LAMP	71
HEATER SWITCH.....	71
OPENING AND CLOSING THE CAB DOOR	72
OPENING AND CLOSING THE FRONT WINDOW DOOR OF THE CAB.....	72
OPENING AND CLOSING THE SIDE WINDOW OF THE CAB.....	73
REMOVING THE FRONT WINDOW BASE.....	73
EMERGENCY HAMMER.....	73
AIR CONDITIONER.....	74
1. Air flow	74
2. Air control vent.....	74
2.1 Front air outlet.....	74
3. Control panel	75
4. Operation.....	75
RADIO	76
BLUETOOTH MICROPHONE	76
IMPACT OF BLUETOOTH.....	76
COMPLIANCE STATEMENT	77
1. FCC Statement.....	77
2. ISED Canada Statement	78
OPERATING THE ENGINE	79
STARTING THE ENGINE	79
STARTING THE ENGINE UNDER COLD CONDITIONS.....	81
STARTING WITH AN AUXILIARY BATTERY	82
CHECK POINTS AFTER STARTING THE ENGINE	82
STOPPING THE ENGINE.....	83
1. Engine stop button.....	83
2. Overheating countermeasures	83
DPF REGENERATION	84
OPERATING THE EXCAVATOR	85
OPERATION OF A NEW MACHINE.....	85
PREPARATIONS BEFORE STARTING THE MACHINE	85
1. Adjusting the operator's seat	85
2. Using the seat belt.....	85
STARTING THE MACHINE	86
1. Pilot control lock lever.....	86
DRIVING	86
1. Drive levers (right, left)	87
TURNS.....	88
1. Pivot turn	88

2. Spin turn	89
UP AND DOWNHILL DRIVING.....	89
PARKING ON A SLOPE	89
OPERATING THE DOZER	90
TWO PATTERN SELECTION SYSTEM (TPSS)	90
1. Pattern change	90
OPERATION OF THE BOOM.....	90
OPERATION OF THE ARM.....	91
OPERATION OF THE BUCKET	91
SWIVEL AND BOOM SWING OPERATION.....	92
1. Swivel operation	92
2. Boom swing operation	92
AUXILIARY PORT OPERATION	92
1. Selecting operation modes	93
2. Operating the AUX port	94
2.1 One-way hold	96
3. Maximum flow volume	97
3.1 Setting the maximum flow volume	97
RELEASING PRESSURE TRAPPED IN THE HYDRAULIC SYSTEM	100
1. Releasing pressure trapped in the AUX port	100
ANGLE BLADE OPERATION [ANGLE BLADE TYPE].....	101
6-IN-1 BLADE OPERATION [6-IN-1 BLADE TYPE]	101
ONE-WAY OR TWO-WAY CIRCUIT SELECTION VALVE OPERATION.....	102
OPERATING THE BOOM LOWERING VALVE	103
AUTO IDLE (AI) OPERATION	103
IMPORTANT INFORMATION ON MACHINE OPERATION	104
TRANSPORTING THE MACHINE.....	105
TRANSPORTING ON A TRUCK	105
TOWING THE MACHINE.....	106
LIFTING THE EXCAVATOR.....	107
BASIC POINTS WHEN LIFTING WITH CABLES OR STRAPS.....	107
SAFETY ASPECTS WHEN LIFTING WITH CABLES OR STRAPS	107
LIFTING THE MACHINE.....	107
MAINTENANCE.....	110
PRECAUTIONS WHEN WASHING THE MACHINE	110
MAINTENANCE INTERVALS	111
1. Air conditioner.....	117
OPENING AND CLOSING THE COVERS	118
1. Opening and closing the engine hood	118
2. Opening and closing the fuel tank cover	118
3. Opening and closing the side cover	119
4. Storing tools.....	119
5. Cup holder	119
6. Where to store the grease gun	119
7. Where to keep the operator's manual.....	120
DAILY CHECKS	120
1. Walk-around inspection	120
2. Checking the coolant level.....	120
3. Checking the fuel level	121
4. Checking the engine oil level.....	121
5. Checking the hydraulic oil level	122
6. Checking the water separator.....	123
7. Checking the radiator and oil cooler	123
8. Checking the ROPS	124
9. Checking the filter indicator	124
10. Checking the V-belt	125

11. Checking the washer liquid	125
12. Checking and cleaning the engine and electrical wiring	125
13. Checking the evacuator valve	125
14. Checking the diesel particulate filter (DPF) muffler	125
15. Checking for exhaust leaks	126
16. Checking the electrical equipment.....	126
17. Checking the seat belt.....	126
18. Greasing the front attachments	126
REGULAR CHECKS AND MAINTENANCE WORK.....	129
EVERY 50 SERVICE HOURS	129
1. Draining water from the fuel tank.....	129
2. Cleaning the water separator	129
3. Checking the battery condition	129
3.1 Charging the battery.....	130
4. Greasing the swivel bearing teeth	131
5. Checking the tracks	131
EVERY 150 SERVICE HOURS	131
1. Cleaning the air conditioner filter	131
EVERY 200 SERVICE HOURS	132
1. Checking the radiator hoses and clamps	132
2. Greasing the swivel bearing	133
3. Inspecting and cleaning the air filter element	133
4. Cleaning the evacuator valve	134
5. Checking the fuel line and intake air line	134
6. Checking the air conditioner condenser	135
EVERY 250 SERVICE HOURS	136
1. Adjusting the V-belt tension	136
1.1 Checking and adjusting the fan belt tension	136
1.2 Checking and adjusting the air conditioner belt tension [CAB type only]	136
2. Greasing the pilot valve linkage.....	137
EVERY 500 SERVICE HOURS	137
1. Replacing the water separator filter element	137
2. Changing the engine oil.....	137
3. Replacing the engine oil filter cartridge	138
4. Changing the drive unit oil	139
5. Replacing the fuel filter cartridge	139
6. Replacing the hydraulic oil tank breather filter.....	139
EVERY 1000 SERVICE HOURS	140
1. Replacing the hydraulic pilot filter element	140
2. Replacing the hydraulic return filter element	141
3. Changing the hydraulic oil (including replacing the suction filter).....	141
4. Checking the hydraulic oil (hydraulic hammer operation).....	143
5. Cleaning the auxiliary valve filter	143
6. Cleaning the pilot line filter	143
7. Checking the engine valve clearance.....	143
EVERY 1000 SERVICE HOURS OR ONCE A YEAR	144
1. Replacing the air filter element	144
EVERY 1500 SERVICE HOURS	144
1. Checking the injector tip	144
2. Checking the EGR cooler	144
EVERY 2000 SERVICE HOURS	144
1. Changing the front idler and track roller oil.....	144
2. Checking the alternator and starter motor	144
EVERY 3000 SERVICE HOURS	144
1. Checking the EGR system	144
2. Checking the turbo charger	144
ANNUAL SERVICING.....	144

1. Checking the electrical wiring and fuses	144
2. Checking the air conditioner pipes and hoses	144
3. Checking the exhaust manifold (cracks, gas leakage, and mounting screw)	145
4. Checking the intake air line for air leaks	145
5. Checking the boost sensor and AFS (Air Flow Sensor)	145
6. Checking the condition of the diesel particulate filter (DPF) muffler	145
7. Checking the diesel particulate filter (DPF) differential pressure sensor and piping for gas leaks	145
8. Checking the diesel particulate filter (DPF) exhaust gas temperature sensor	145
9. Checking the EGR piping for gas leaks	145
BIENNIAL SERVICING	145
1. Replacing the air conditioner pipes and hoses	145
2. Replacing radiator hoses and hose clamps	145
3. Changing the radiator coolant	146
4. Replacing the fuel hoses and hose clamps	147
5. Replacing the intake air line	147
6. Replacing the diesel particulate filter (DPF) differential pressure sensor rubber piping (front and back)	148
7. Replacing the suction pipe downstream the AFS (Air Flow Sensor)	148
8. Replacing the EGR cooler hoses	148
9. Replacing the hydraulic hoses	148
SERVICING AS REQUIRED	148
1. Checking the quantity of refrigerant (gas)	148
2. Draining the water separator	149
3. Cleaning the diesel particulate filter (DPF)	149
4. Cleaning the plastic parts and synthetic leather	149
OTHER ADJUSTMENTS AND REPLACEMENTS	150
PURGING THE FUEL SYSTEM	150
ADJUSTING THE TRACKS	150
1. Adjusting steel tracks	150
2. Adjusting rubber tracks	151
2.1 Special information regarding the use rubber tracks	152
CHANGING THE BUCKET	153
REPLACING FUSES	153
REPLACING SLOW-BLOW FUSES	154
TROUBLESHOOTING	156
TROUBLESHOOTING OF THE ENGINE AND OTHER SYSTEMS	156
OPERATION IN COLD WEATHER	158
PREPARATION FOR WORK IN COLD WEATHER	158
AFTER WORKING IN COLD WEATHER	158
LONG-TERM STORAGE	159
STORING THE MACHINE	159
OPERATING THE MACHINE AFTER LONG-TERM STORAGE	159
PERIODIC REPLACEMENT OF PARTS	159
RECOMMENDED OILS AND FUELS	161
BIODIESEL FUEL (BDF)	163
REQUEST REGARDING FUEL USE AND MAINTENANCE OF CRS DIESEL ENGINES	165
APPENDICES	166
MAIN DIMENSIONS	166
LIFTING CAPACITY	167
IMPORTANT INFORMATION	167
LIFTING CAPACITY OF (CANOPY, RUBBER TRACK, STANDARD BLADE)	168
LIFTING CAPACITY OF (CANOPY, STEEL TRACK, STANDARD BLADE)	169
LIFTING CAPACITY OF (CANOPY, RUBBER TRACK, ANGLE BLADE)	170

LIFTING CAPACITY OF (CANOPY, STEEL TRACK, ANGLE BLADE).....	171
LIFTING CAPACITY OF (CANOPY, RUBBER TRACK, 6-IN-1 BLADE)	172
LIFTING CAPACITY OF (CANOPY, STEEL TRACK, 6-IN-1 BLADE).....	173
LIFTING CAPACITY OF (CAB, RUBBER TRACK, STANDARD BLADE)	174
LIFTING CAPACITY OF (CAB, STEEL TRACK, STANDARD BLADE).....	175
LIFTING CAPACITY OF (CAB, RUBBER TRACK, ANGLE BLADE).....	176
LIFTING CAPACITY OF (CAB, STEEL TRACK, ANGLE BLADE).....	177
LIFTING CAPACITY OF (CAB, RUBBER TRACK, 6-IN-1 BLADE).....	178
LIFTING CAPACITY OF (CAB, STEEL TRACK, 6-IN-1 BLADE)	179
LIST OF SCREENS	180
NAVIGATION SCREENS	180
AUTOMATIC DIESEL PARTICULATE FILTER (DPF) REGENERATION	187
LOCKING AND RELEASING THE DIESEL PARTICULATE FILTER (DPF) REGENERATION	189
SOFTWARE INFORMATION	191
INDEX.....	192

SAFE OPERATION

The best way to prevent accidents is to follow the safety instructions and warnings in this manual, regulations, and safe operating practices.

Read and understand this manual before operating the machine.

Every user, however experienced, should carefully read and understand this manual and those of the attachments and accessories before operating the machine. The owner is obliged to inform the operators of these instructions in detail.

Store this manual in the back of the seat.

(See Where to keep the operator's manual on page 120.)

BEFORE OPERATING THE MACHINE

1. General

- Obey the safety labels on the machine.
- The seat belt must be inspected regularly and replaced if frayed or damaged.

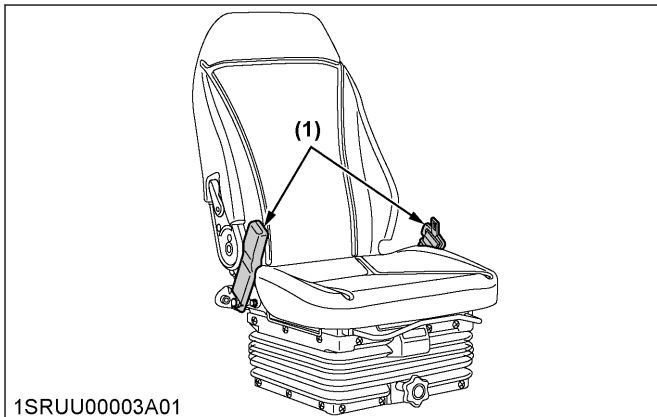

(1) Seat belt

- Always sit in the operator's seat when starting the engine or operating levers or controls.
- Study control lever pattern A and pattern B. Then choose the one which feels most familiar. Familiarize yourself with the pattern selected by operating the machine slowly and at low engine speed.
 - Engage the lever lock to prevent accidental pattern change.

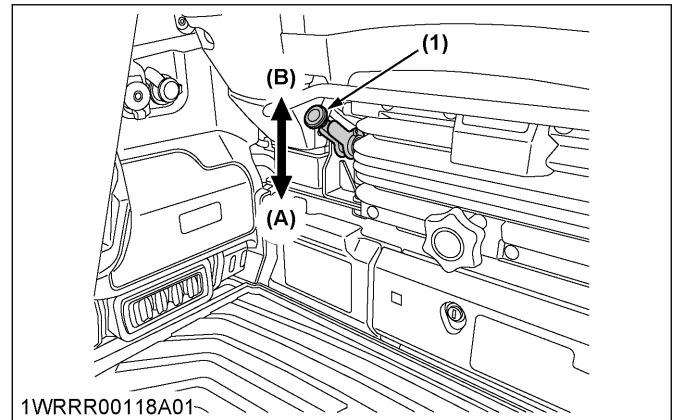

(1) Pattern selector lever (two pattern selection system: TPSS) (A) Pattern A (B) Pattern B

- Do not operate the machine while under the influence of alcohol, medication, controlled substances or while fatigued.
- Check the surroundings carefully before using the machine or when attachments are being attached.
 - Pay attention to overhead clearances with electric wires.

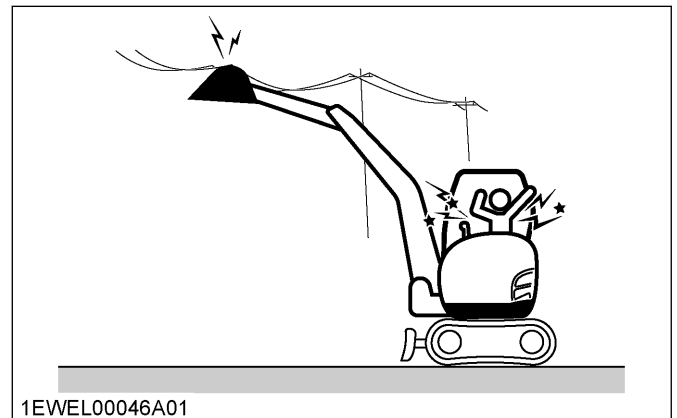

- Check for pipes and buried cables before digging.
- Check for hidden holes, obstacles, soft underground, and overhangs.

! SAFE OPERATION

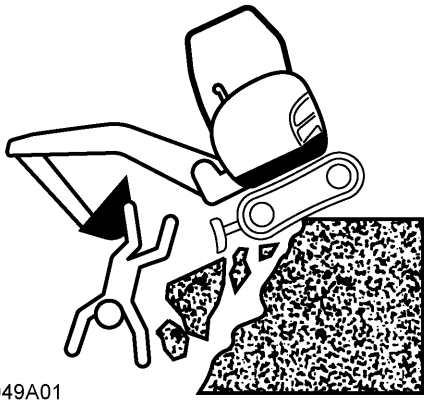

1EWEL00049A01

- While using the machine, do not allow any persons within the working range.
- Check local regulations and call 811 before digging.
- Do not allow other persons to use the machine before having informed them of the exact operation and work instructions, and make sure that they have read and fully understood the operator's manual.
- Do not wear baggy, torn or oversized clothing when working with the machine as such clothing can get caught in rotating parts or control elements which can cause accidents or injuries. Wear adequate safety clothing, such as a safety helmet, safety shoes, eye protection, ear protection, working gloves and so on, as necessary and as prescribed by law or other standards or regulations.

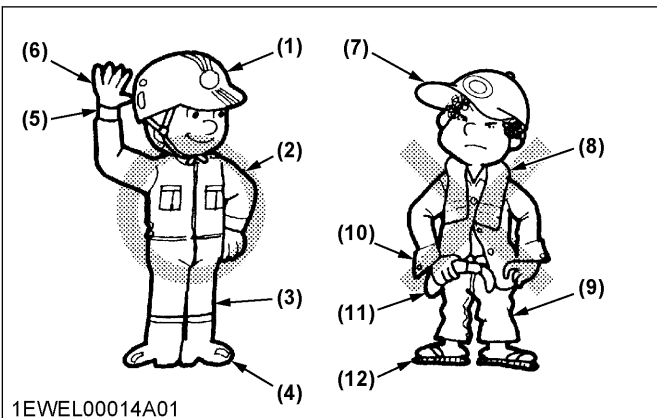

1EWEL00014A01

- | | |
|----------------------------------|--|
| (1) <i>Helmet</i> | (7) <i>Soft hat</i> |
| (2) <i>Clothing fit for work</i> | (8) <i>Towel</i> |
| (3) <i>Tight seams</i> | (9) <i>Baggy trousers</i> |
| (4) <i>Good grip footwear</i> | (10) <i>Loose cuffs of the shirt</i> |
| (5) <i>Well fitting cuffs</i> | (11) <i>Baggy shirt</i> |
| (6) <i>Working gloves</i> | (12) <i>Sandals or open-toed shoes</i> |

- Do not allow passengers to ride on any part of the machine at any time. The operator must remain in the machine seat during operation.
- Check mechanical parts for wear, and make sure that they are correctly adjusted. Replace worn or damaged parts immediately. Check nuts and bolts regularly to make sure that they are tightened to the correct torque.

- Keep your machine clean. Heavy soiling, grease, dust and grass can cause fires, accidents or injuries.
- Use only Kubota's authorized attachments.
- Before starting the machine, be absolutely sure that the machine has been filled with fuel, lubricated, greased and undergone all necessary maintenance.
- Do not modify the machine.
- Do not operate a hydraulic hammer on anything that is above the operator's seat level as objects may fall into the operator station.
- Make sure that attachments, particularly those utilizing quick attach systems, are securely mounted.
- Install protective guards on the machine when working in areas where objects may fall or be thrown.

2. ROPS and OPG

- For your safety, a roll-over protective structure (ROPS) with a seat belt or operator protective guard, top guard level I (OPG, top guard level I) with a seat belt is installed by Kubota. The OPG (top guard level I), in accordance with ISO10262, is equivalent in definition to a falling object protective structure (FOPS).
- Always use the seat belt when the machine is equipped with a ROPS or OPG (top guard level I) as this combination will reduce the risk of serious injury or death in case of machine tip-over or instability, or in case of falling objects.
- Do not modify any structural members of the ROPS or OPG (top guard level I) by welding, drilling, bending, grinding or cutting, as this may weaken the structure.
- If any component is damaged, replace it. Do not attempt repairs.
- If the ROPS or OPG (top guard level I) is loosened or removed for any reason, make sure all parts are reinstalled correctly. Tighten the mounting bolts to the proper torque.
- The ROPS meets the requirements of ISO 3471. The OPG (top guard level I) meets the requirements of OSHA 1926.1003 / ISO 10262.
- Never operate the machine when the operating mass including the operator exceeds the maximum permissible total weight indicated on the ROPS identification plate.

! SAFE OPERATION

[Canopy]

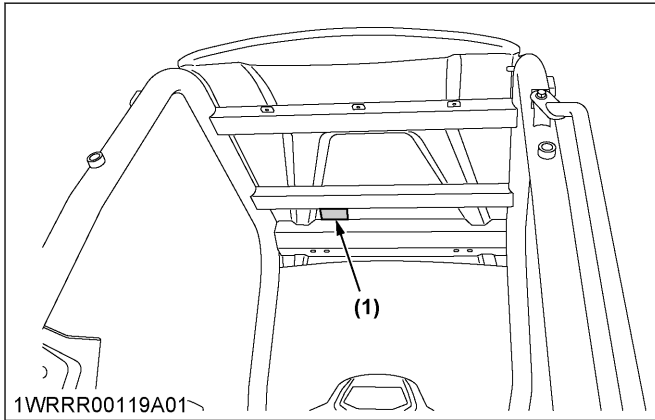

(1) ROPS identification plate

[CAB]

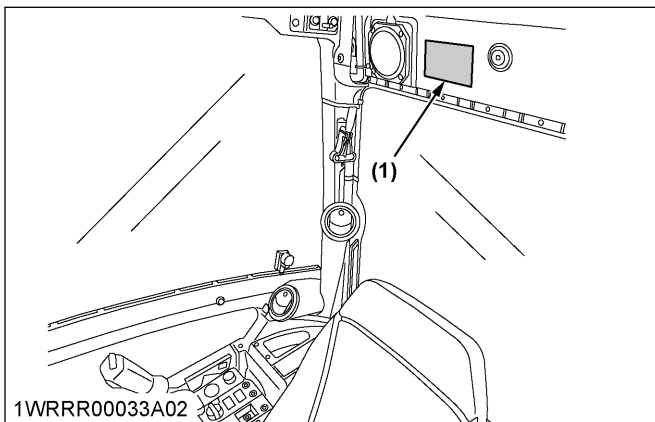

(1) ROPS identification plate

OPERATING THE EXCAVATOR

1. Starting to operate the machine

- Get into and out of the machine safely. Always face the machine. Always use handrails and available steps and keep yourself well balanced. Do not hold any of the control levers or switches. Do not jump on or off the machine, whether stationary or in motion.
- Start and control the machine only from the operator's seat. The driver should not lean out of their seat when the engine is running.
- Before starting the engine, make sure that lock levers are in the LOCK positions, all control levers and pedals are in their "NEUTRAL" positions, and the seat belt is fastened correctly.
Before starting the engine, make sure that the control levers, travel lever, pedals, and other control elements are not stuck and can be moved smoothly.
If any issues are found, immediately pinpoint the cause and correct it.
- Be mindful of the location of the dozer blade while traveling (the dozer must be raised). If the levers

are activated with the dozer blade at the rear, the tracks will move in the opposite direction of the drive levers.

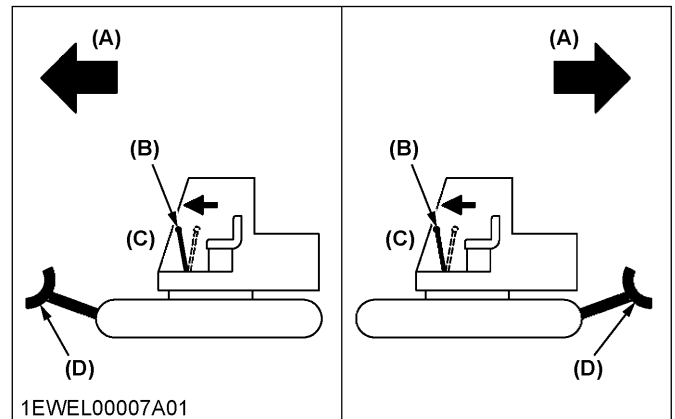

- (A) Travel direction
- (B) Drive levers
- (C) Front
- (D) Dozer blade

2. Working the machine

- Do not operate or idle engine in a non-ventilated area. Carbon monoxide gas is colorless, odorless, and deadly. If you experience the initial symptoms of low to moderate CO poisoning, which include headaches, fatigue, shortness of breath, nausea, or dizziness, stop operation and seek medical attention.

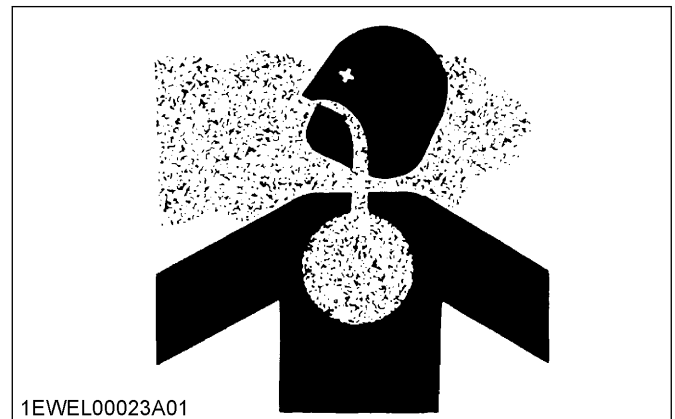

- Keep all safety equipment and covers in place. Replace damaged or missing safety devices.
- When operating the machine, keep hands and body inside of the ROPS or OPG (top guard level I) protective envelope. Do not touch or depress the control levers or the pedals from outside the CAB while the engine is running.
- Operate the machine so that it does not tip over. Keep away from steep slopes and embankments. Do not swing the bucket downhill. Lower the dozer during digging. Keep the bucket as low as possible while driving uphill. Turn slowly on slopes (at reduced speed). Do not place the machine near the

! SAFE OPERATION

edges of trenches and banks, as the earth can give way due to the weight of the machine.

Never cross an incline horizontally or at an angle, as it can cause the machine to roll over. Approach inclines head-on to avoid the loss of control.

Avoid performing any work with the machine when it is on an incline, as this could cause the machine to become unbalanced and roll over. Always take care when moving the machine on an incline.

Allowable climbing angle	36 % (20 degrees)
--------------------------	-------------------

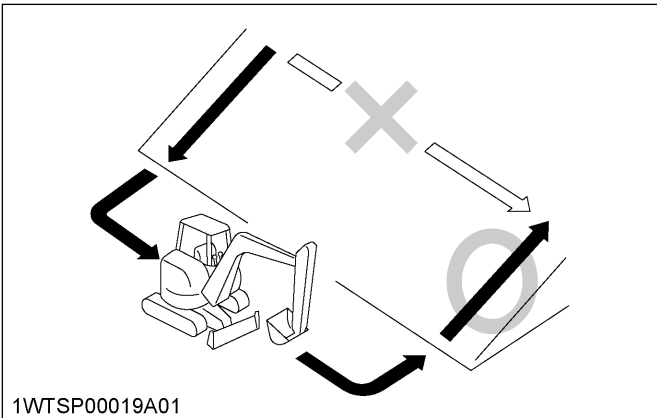

1WTSP00019A01

- Always pay close attention to the area to which the machine is being moved.
- Do not change direction on steep slopes, as the machine could roll over. Before changing direction, be aware of people in the work area.
- Details regarding the operation of the machine can be found in a different section. (See OPERATION OF A NEW MACHINE on page 85.)

3. Safety for children

Tragedy can occur if the operator is not alert to the presence of children. Children generally are attracted to machines and the work they do.

- Never assume that children will remain where you last saw them.
- Keep children out of the work area and under the watchful eye of another responsible adult.
- Be alert and shut your machine down if children enter the work area.
- Never carry children on your machine. There is no safe place for them to ride. They may fall off and be run over or interfere with your control of the machine.
- Never allow children to operate the machine even under adult supervision.
- Never allow children to play on the machine or on the attachments.
- Use extra caution when backing up. Look behind and down to make sure the area is clear before moving.

3.1 Avoiding crystalline silica (quartz) dust

To avoid serious injury or death from silica dust:

- Avoid exposure to dust containing crystalline silica particles.

This dust can cause serious injury to the lungs (silicosis).

Because crystalline silica is a basic component of sand and granite, many activities at construction sites produce dust containing crystalline silica.

Trenching, sawing and boring of material containing crystalline silica can produce dust containing crystalline silica.

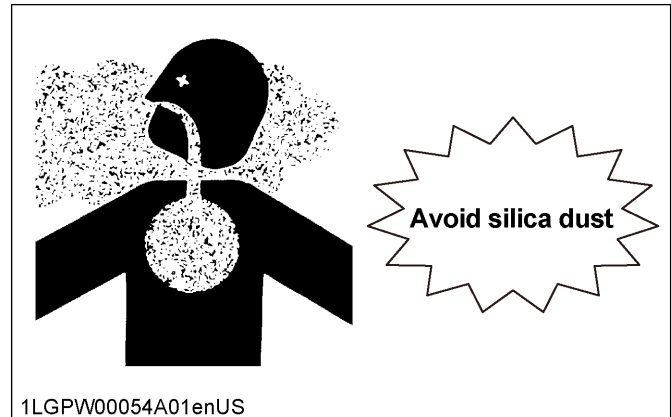

1LGPW00054A01enUS

- If dust which contains crystalline silica is present, there are guidelines which should be followed:
 - Be aware of the potential health effects of crystalline silica and that smoking may add to the damage.
 - Be aware of and follow OSHA (or other local, State or Federal) guidelines for exposure to airborne crystalline silica.
 - Know the work operations where exposure to crystalline silica may occur.
 - Participate in air monitoring or training programs offered by the employer.
 - Be aware of and use optional equipment controls such as water sprays, local exhaust ventilation, and enclosed CABS with positive pressure air conditioning, if the machine has such equipment. Otherwise respirators shall be worn.
 - Where respirators are required, wear a respirator approved for protection against crystalline silica containing dust. Do not alter the respirator in any way. Workers who use tight-fitting respirators cannot have beards/mustaches which interfere with the respirator seal to the face.
 - If possible, change into disposable or washable work clothes at the work site; shower and change into clean clothing before leaving the work site.

! SAFE OPERATION

- Do not eat, drink, use tobacco products, or apply cosmetics in areas where there is dust containing crystalline silica.
- Store food, drink and personal belongings away from the work area.
- Wash hands and face before eating, drinking, smoking, or applying cosmetics after leaving the exposure area.

AFTER OPERATION

Before leaving the machine:

- Park the machine on a firm, flat and level surface. If this is not possible, put the bucket on the ground and place all control levers in their "NEUTRAL" positions, then brace the tracks with chocks.
- Do not park the machine anywhere there are combustible materials such as dried grass or straw.
- Lower the attachments and the dozer blade to the ground.
- Stop the engine.
- Release the pressure from the hydraulic system.
- Lock all control levers.
- Lock the CAB door (if equipped).

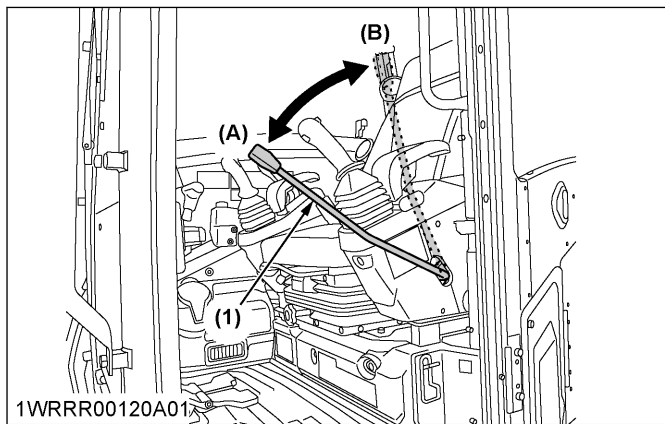
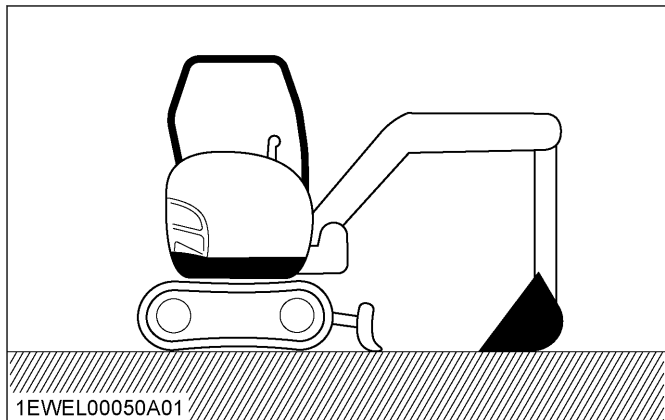

(1) Pilot control lock lever

(A) UNLOCK
(B) LOCK

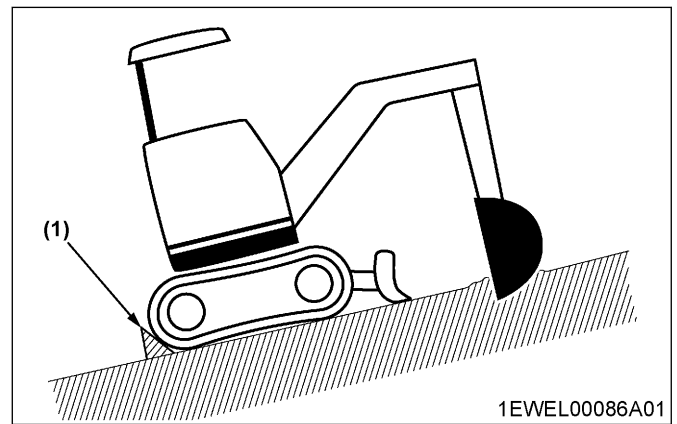

(1) Chock

SAFE LOADING AND TRANSPORT OF THE MACHINE

- Observe all regulations concerning the transport of machine on public roads.
- Use adequately long and robust ramps when loading the machine.
(See TRANSPORTING THE MACHINE on page 105)
- Do not change the running direction. To avoid tipping over, do not try to swing the attachment crosswise to the loading ramps.
- Lower the attachment on the loading bed and release the pressure from the hydraulic system. Block the tracks with blocks and chain down the machine. After loading the machine on the vehicle, securely chain down the undercarriage of the machine using suitable chains, tensioners, and approved methods.

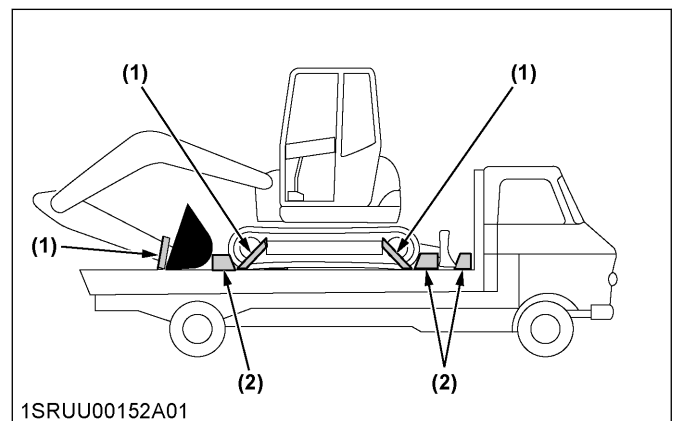

(1) Chain

(2) Block

- Avoid abrupt braking of the vehicle with the machine loaded. Sudden braking causes the machine to move and may cause a serious accident.
- When towing another machine or pulling a load, the load must be less than the strength of the towing

⚠️ SAFE OPERATION

line attached to machine. The towing eye should not be used to tie down or lift the machine.

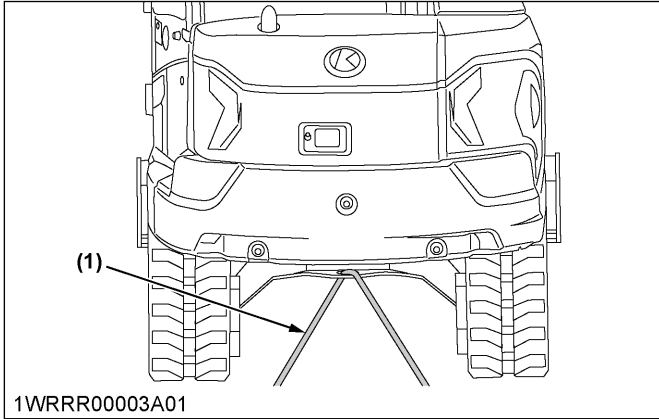

(1) Tow line

Maximum drawbar pull at coupling hook	69.5 kN (15624 lbf, 7087 kgf)
Maximum vertical load at coupling hook	12.1 kN (2721 lbf, 1234 kgf)

- Do not use the hooks on the roof of canopy and CAB for lifting the machine.

MAINTENANCE

1. Precautions when performing checks or maintenance

Before doing maintenance work on the machine, park the machine on a firm, flat and level surface, lower the attachments to the ground, stop the engine, release pressure trapped in the hydraulic system, lock all control levers. When dismantling hydraulic parts, make sure that the hydraulic oil has cooled down sufficiently to avoid burns. Start maintenance work carefully, such as loosening a plug slowly so that oil will not squirt out.

- Before doing work on the engine, the exhaust system, the radiator and the hydraulics, let the machine cool down sufficiently.
- Always turn off the engine when filling the fuel tank. Avoid spilling and over-filling of fuel.
- Keep a first aid box and a fire extinguisher handy at all times.
- Use eye protection and a face mask to protect the eyes and respiratory system against dust and other foreign particles.

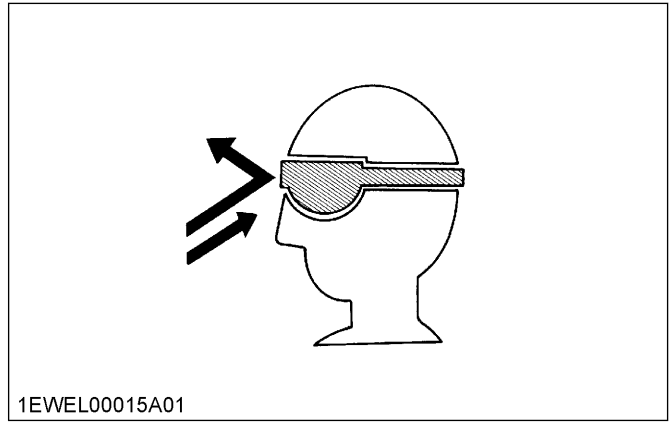

- Inspect ROPS/OPG (top guard level I) for damage and if damage is found contact your Kubota dealer for repairs.
- Kubota does not use components which contain asbestos and recommends against the use of such components.
- To avoid hazardous high voltage, turn the starter switch to the **[STOP]** position if it is necessary to check to repair the computer, harness or connectors.
- Prohibit unauthorized persons from entering the work area to prevent injury caused by debris flying off of machine parts during grinding, welding, using a hammer, or other tasks.
- Make sure that the work area is clear and safe. Work on a firm, level surface with adequate lighting. Work in well-ventilated area if you work indoors. Make sure that the area is free from any potentially dangerous conditions such as obstacles, slippery surfaces, and so on.
- Make sure that the machine is clean and free of debris.
 - Always remove any debris from the machine and clean it before performing maintenance or repair work.
 - Before washing or cleaning the machine using water, stop engine and make sure that all of the electrical parts and devices are covered. Any water seepage into the electrical wiring on the machine can cause a short circuit or cause the controls to malfunction. Never use water or steam to clean any of the electrical parts and devices, such as the battery, the sensors, or the connectors.

! SAFE OPERATION



- Always make sure that the engine is stopped before performing any maintenance or repairs. Otherwise, clothing, tools, hands, or other parts of the body can get caught in moving parts of the machine, causing personal injury or death.

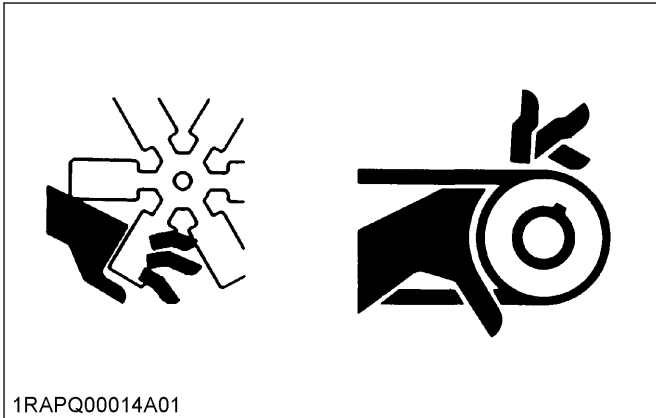

- Do not lubricate or mechanically adjust while the engine is running, even if the machine is stationary.
- Exercise caution when refueling:
 - Never smoke cigarettes or permit the use of fire while refueling or in the vicinity of refueling.
 - Always make sure that the engine is off and cool before removing the fuel cap to refuel the tank. Avoid getting fuel on any hot components.
 - Keep control of the fuel-filler-nozzle while refueling.
 - Never overfill the tank with fuel. Leave room for thermal expansion.
 - Always remove any excess or spilled fuel immediately.
 - Always make sure that the fuel-tank-cap is securely reinstalled.
Replace the fuel-tank-cap only with a manufacturer-approved cap whenever it becomes damaged. Use of the wrong type of cap may not allow for proper venting, causing pressure in the tank to build up.
 - Never use fuel to clean the machine.
 - Always use the correct type of fuel for the machine and the temperature in which it is being operated.
 - Always use a properly grounded fueling system.

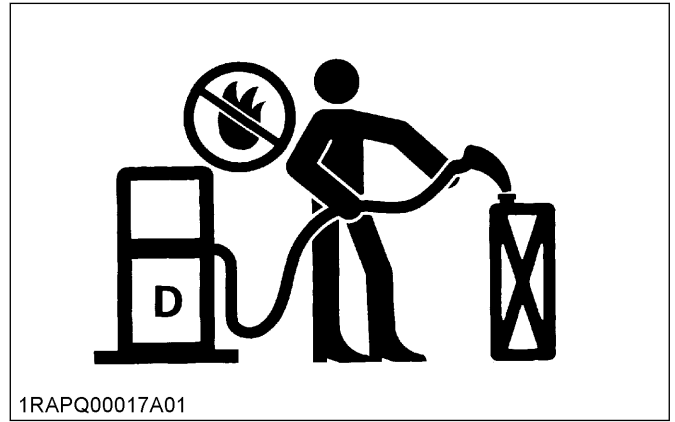

- Use caution when working around hot and pressurized components.
 - Always allow the engine to cool sufficiently before performing any maintenance, inspection, or repairs.
 - Never touch any parts such as the engine, the muffler, the radiator, the hydraulic lines, the sliding parts, and so on as they may be very hot immediately after the machine has been running and can cause burning. Allow the engine, the muffler, the radiator, the hydraulic lines, the sliding parts, and so on to cool sufficiently before touching them.
 - Always use sufficient care whenever removing the caps and plugs on the coolant, oil, and hydraulic fluid as they are hot and pressurized and can cause burning and injury from spraying of hot fluid.

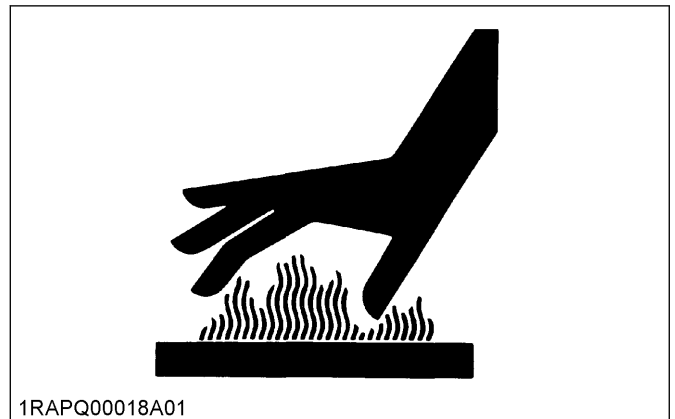

- Always carefully check the machine after performing any maintenance or repairs. Confirm that no oil, water, and so on is leaking from any parts that had been serviced by carefully inspecting the parts. Gradually speed up the engine from a low speed to higher speed to check operation.

2. Handling the battery

- Smoking is prohibited while refueling or handling the battery. Keep sparks and fire away from the fuel

! SAFE OPERATION

tank and battery. Flammable gases escape from the battery, especially during charging.

- Do not use or charge a refillable type battery if the fluid level is below the **[LOWER]** (lower limit level) mark. Otherwise, the battery component parts may prematurely deteriorate, which may shorten the battery's service life or cause an explosion. Check the fluid level regularly and add distilled water as required, so that the fluid level is between the **[UPPER]** and **[LOWER]** levels.
- To avoid sparks from an accidental short circuit, always disconnect the ground cable (-) of the battery first and reconnect it last.
- Read and follow the instructions when starting with an auxiliary battery.
(See STARTING WITH AN AUXILIARY BATTERY on page 82.)

3. Handling the radiator

- Do not open the radiator cap before the radiator has cooled down sufficiently.
Once the radiator has cooled sufficiently, loosen the cap to the first stop and allow the system enough time to release the remaining pressure. Then loosen the cap completely.

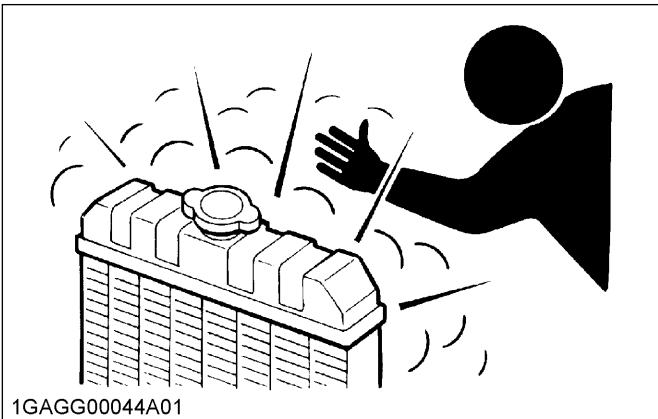

4. Handling the hydraulic components

- Make sure that pressure from all systems is sufficiently released before performing any maintenance or repairs. Oil or other fluids could be released when caps or filters are removed before the pressure has been stabilized in the hydraulic system.
 - Gradually release internal pressure build-up by standing out of the line of any possible spray and slowly removing plugs, screws, or disconnect hoses.
- Leaking hydraulic fluid has enough pressure to penetrate the skin and cause serious injuries. Leakages from pin holes can be totally invisible. Do

not use hands for checking for leaks. Always use a piece of wood or cardboard. It is strongly recommended that you use a face shield or eye protection.

In case of injuries caused by leaking hydraulic fluid, contact a doctor immediately. This fluid can cause gangrene or serious allergic reactions.

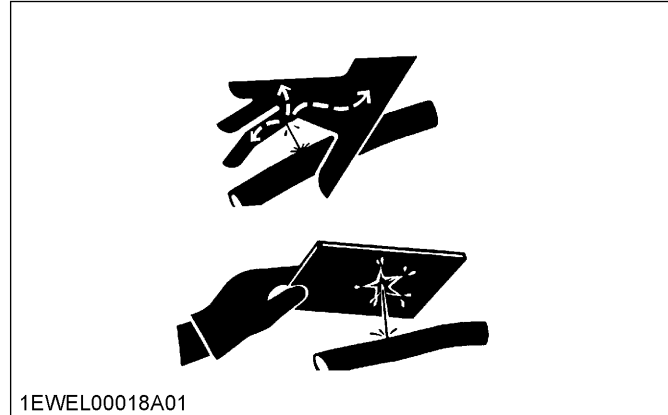

- Do not dismantle the spring of the track tensioner. If dismantling is necessary, contact your Kubota dealer. The assembly must be done according to the Kubota work shop manual (WSM) for the product involved.
- Always use care whenever using grease that is pressurized.
 - Always follow the proper procedure to adjust tension.
Grease in the track adjuster is pressurized and improper release can cause the discharge valve to fly off, causing personal injury or death.
 - Always loosen the grease fitting slowly.
 - Avoid standing in front of, or putting any parts of the body in the line of the grease fitting.
 - If no grease is released when the grease fitting is loosened, the machine has a malfunction. Do not perform repairs of any kind yourself and contact the local dealer for repairs. If no grease is released when the grease fitting is loosened, any operation of the machine can be very dangerous.

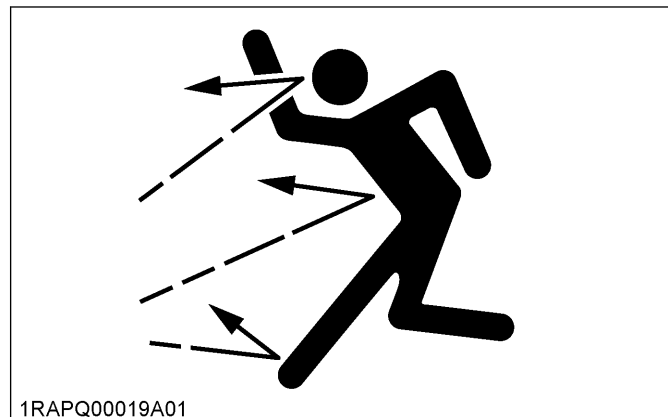

5. Precautions when using the front attachments to lift the machine

- Securely support the machine with stands or suitable blocking before working underneath. For your safety, do not work under any hydraulically supported devices. They can settle, suddenly leak down, or be accidentally lowered.

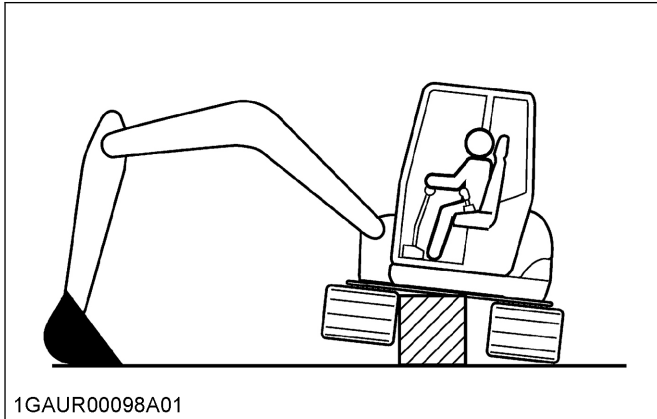

- When lifting the machine itself with an attachment, place a safety block or safety post to prevent the machine from rolling over. Keep the pilot control lock lever in the LOCK position.

6. Handling the high-pressure fuel system

- Do not open high-pressure fuel system. High-pressure fluid remaining in fuel lines can cause serious injury. Do not disconnect nor attempt to repair fuel lines, sensors, or any other components between the high-pressure fuel pump and injectors on engines with high-pressure common rail fuel system.

7. Fire prevention

- The machine and some attachments have components that are at high temperatures under normal operating conditions. The primary source of high temperatures is the engine and exhaust system. The electrical system, if damaged or incorrectly maintained, can be a source of arcing or sparks. The following fire prevention guidelines will help to keep your equipment up and running efficiently and keep the risk of fire to a minimum.
 - Blow off all accumulated debris near hot engine exhaust components such as the turbocharger, exhaust manifold, exhaust pipes and muffler. Do this more frequently when working in severe conditions.
 - Clean out all accumulated flammable debris (such as leaves, straw, pine needles, branches,

bark, small wood chips) and any other combustible materials from inside the machine belly pans or lower unit structures as well as from the area in proximity to the engine.

- After use and pressure-washing, make sure there is nothing flammable near the exhaust pipe. Grass, twigs, or other organic debris under the hood may cause fire.
- Inspect all fuel lines and hydraulic hoses for wear or for deterioration. Replace them immediately if they begin to leak.
- Examine electrical wiring and connectors frequently for damage. Repair any wires that are loose or frayed before operating the machine. Clean all electrical connections and tighten them as necessary.
- Inspect the exhaust system daily for any signs of leakage. Check for broken pipes and muffler and also for loose or missing bolts, nuts and clamps. If any exhaust leaks or fractured parts are found, repairs must be completed prior to operation.
- Always keep a multipurpose fire extinguisher on or near the machine. Be familiar with the operation of the fire extinguisher.
- Do not weld on pipes or tanks containing flammable liquids. Do not gas cut pipes or tanks containing flammable liquids. Before doing any such work, carefully drain any flammable fluids. Then clean pipes and tanks thoroughly with a non-flammable solvent before welding or cutting.
- To prevent personal injury or death, use explosion-proof lighting when working on, inspecting, or using fuel, oil, coolant, battery fluid, and so on. If you do not use the explosion-proof lighting or if it breaks, it can ignite and cause fire, injury, or death.

WASTE MATERIAL

- Always make sure that any material and waste products from the repair and maintenance of the machine are collected into proper containers using a funnel, or other device. Dispose of waste material properly to avoid pollution and contamination of the environment.
- Consult local regulations and codes when disposing of oil, fuel, engine coolant, refrigerant, solvents, filters, batteries, and any other potentially harmful and hazardous material or substance.

SAFE OPERATION

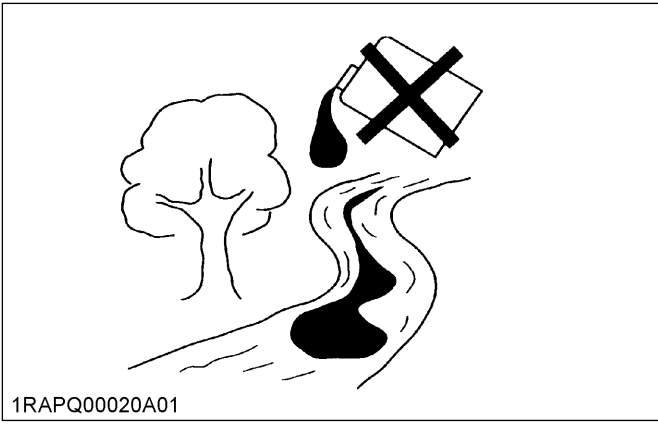

SAFETY LABELS

[CAB]

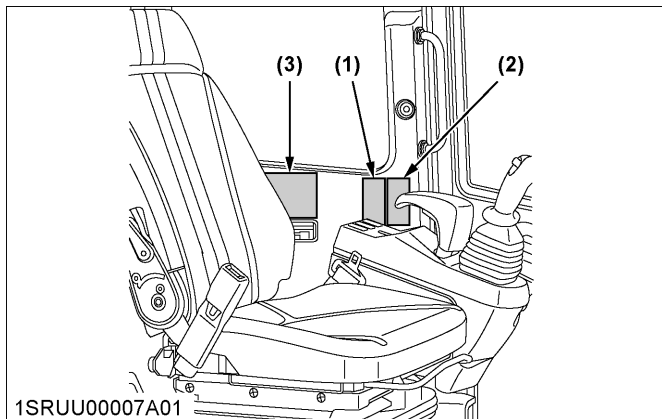

(1) Part No. RD809-5738-2

[Canopy]

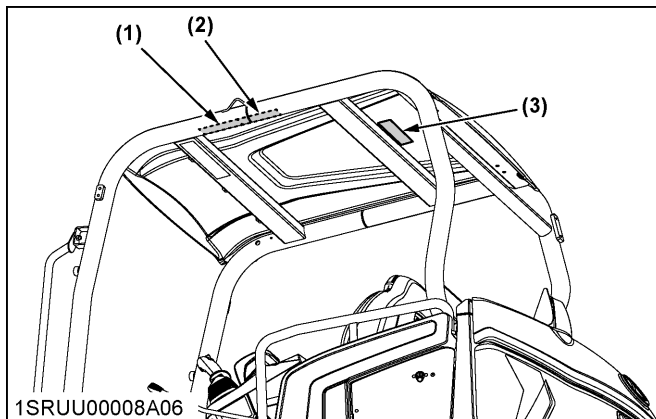

(2) Part No. RD809-5736-1



(3) Part No. RD578-5727-1



! WARNING

<p>TRAVEL DIRECTION</p>	<p>TRAVEL DIRECTION</p>	<p>TO AVOID PERSONAL INJURY OR DEATH: Before moving the excavator, KNOW THE LOCATION OF THE DOZER BLADE. The excavator will travel in the direction of the dozer blade when drive levers are moved away from the operator.</p>
<p>DO NOT OPERATE WITHOUT ROPS. YOU COULD BE CRUSHED.</p>	<p>USE SEAT BELT</p>	

⚠ SAFE OPERATION

[CAB]

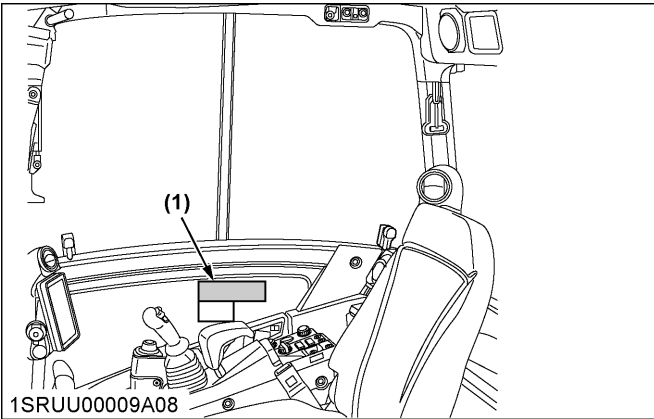

[Canopy]

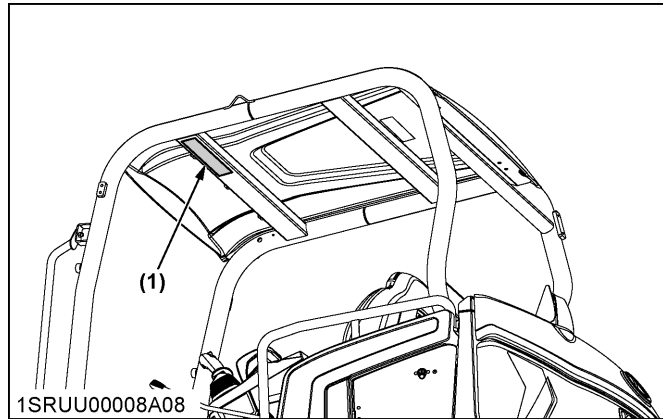

(1) Part No. RC488-5728-1

⚠ WARNING

IMPORTANT

TO AVOID PERSONAL INJURY OR DEATH:

1. Read and understand operator's manual before attempting to start or operate the excavator. Read the manual of the attachment to do a correct operation safely when other attachments are installed instead of Kubota specified bucket.
2. Before starting engine, make sure all control levers are in neutral and the operating area is clear of all bystanders.
3. Never allow passengers on any part of the excavator while operating.
4. Know your work area before starting operation.
 - Check underground lines and cables.
 - Stay off slopes too steep for safe operation.
 - Check for hidden holes, obstacles or drop-offs and overhangs.
5. Make sure all shields are in place and securely fastened.
6. Before dismounting from the machine, lower all attachment to the ground, stop the engine and remove the key.
7. Damaged ROPS must be replaced, not repaired or revised.

Never use boom, dipper, or bucket to hammer or beat sideways.
Excavator is not intended for these usages.

! SAFE OPERATION

[CAB]

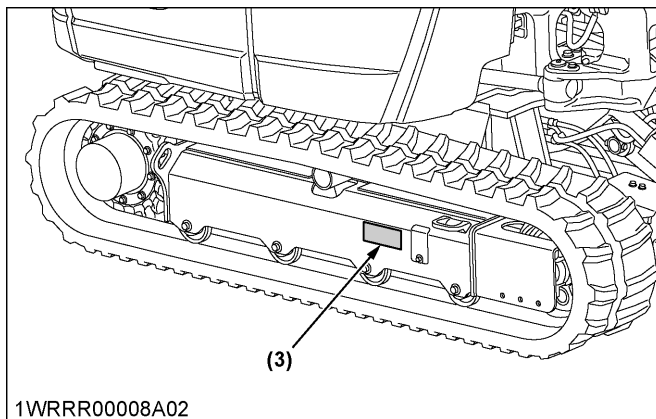
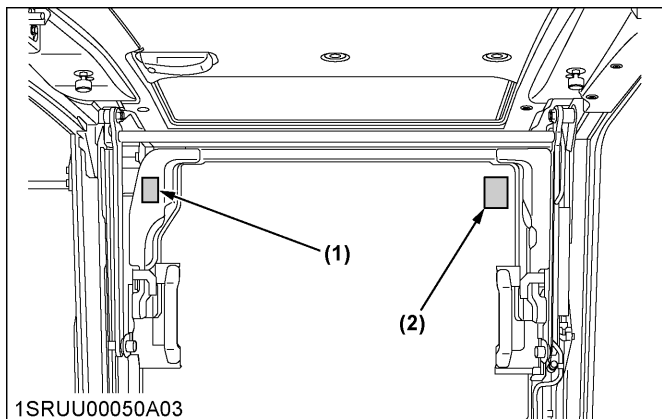

(1) Part No. RD579-5793-1 [CAB]

Do not forget to lock the front window.

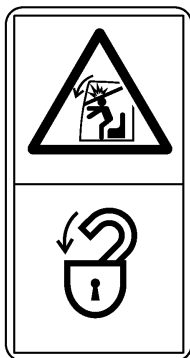

(2) Part No. RC488-5785-1 [CAB]

Open the front window slowly to avoid being hit in the body.



(3) Part No. RB456-5795-1 (both sides)

There is a risk of grease fittings flying off and causing injury.

When loosening the crawler, read the operator's manual and take the correct measures.

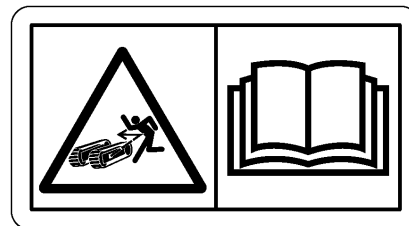

⚠️ SAFE OPERATION

[CAB]

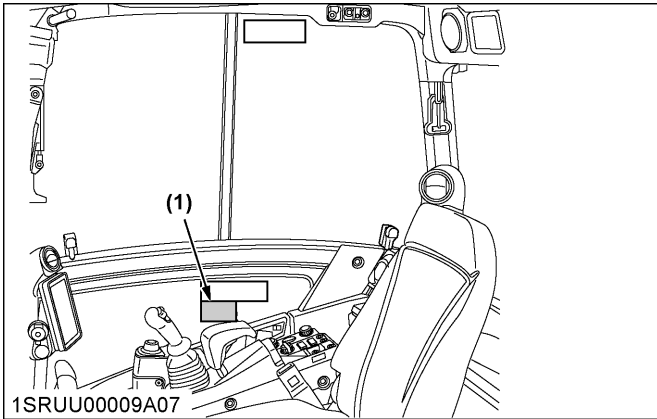

(1) Part No. RD358-5745-1
[Standard blade type]

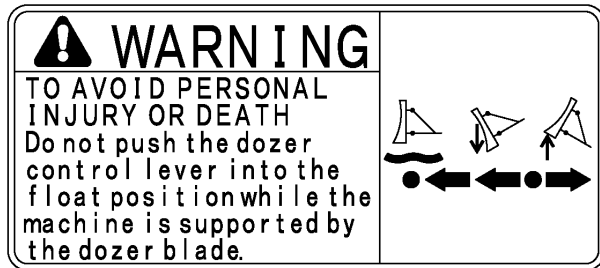

[Canopy]

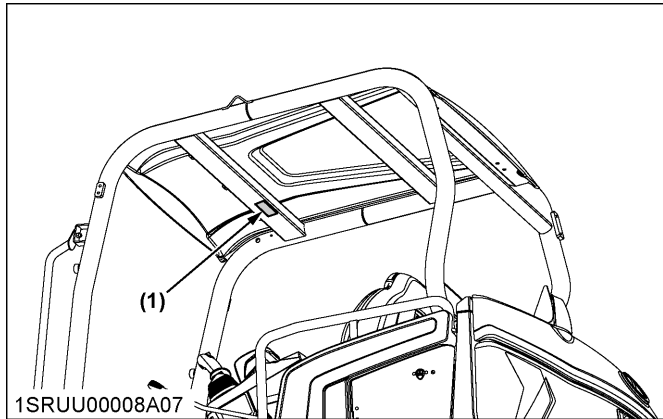

(1) Part No. RD188-7596-1
[Angle blade type]

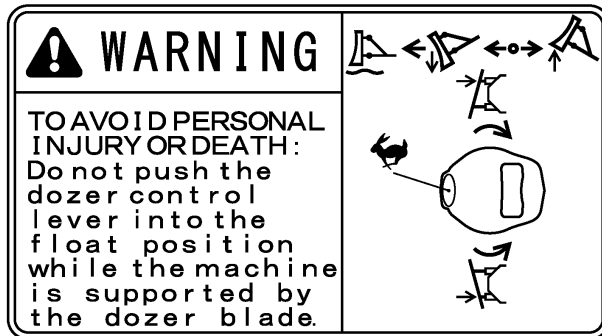

(1) Part No. RD188-7698-1
[6-in-1 blade type]

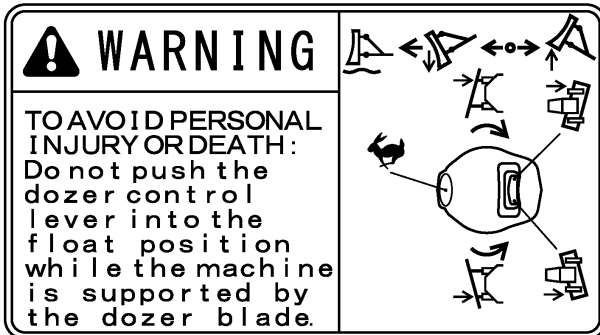

! SAFE OPERATION

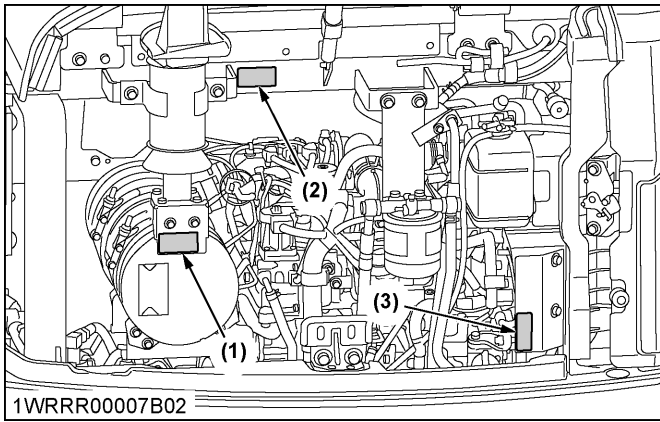

(1) Part No. RD579-5745-1

Touching the muffler or other high-temperature sections of the machine during operation or after stopping can cause burns. Do not touch the high-temperature sections of the machine.

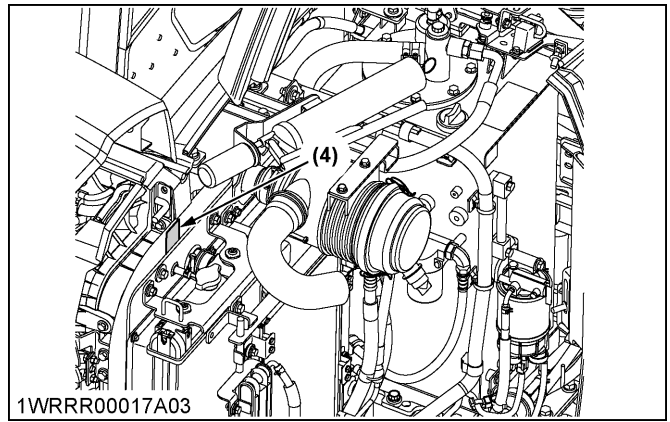
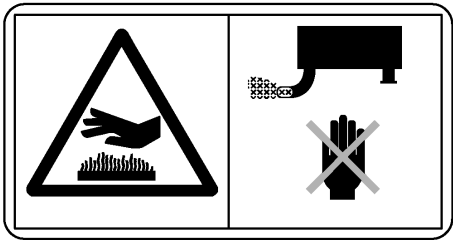

(2) Part No. RD579-5725-1

Touching the muffler or other high-temperature sections of the machine during operation or after stopping can cause burns. Do not touch the high-temperature sections of the machine.

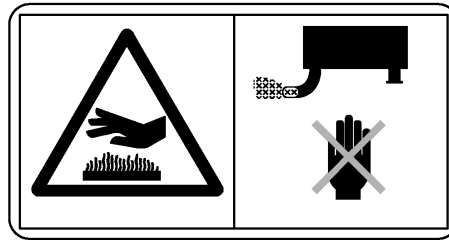

(3) Part No. 6C090-4958-2

There is a risk of being caught in the rotating sections of the fan and the fan belt, causing injury. When performing inspections and maintenance, completely stop the rotation.



(4) Part No. RC488-5754-1



SAFE OPERATION

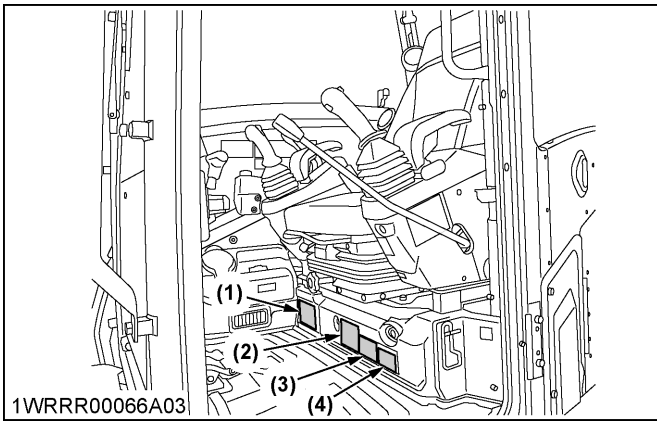

(1) Part No. RD578-5732-1

(2) Part No. 3B791-9870-3

<p>⚠ WARNING</p> <p>TO AVOID PERSONAL INJURY OR DEATH:</p> <ol style="list-style-type: none"> 1. Study control lever pattern A and pattern B. Then choose the one which is most familiar. 2. Position the pattern selector lever in either the lowered position (pattern A) or the upward position (pattern B). 3. Engage lever lock to prevent accidental pattern change. 4. Familiarize yourself with the pattern selected by operating slowly. 	<p>Pattern B</p>  <p>Pattern A</p>
---	---

<p>⚠ WARNING</p> <p>TO AVOID EXPOSURE TO DUST CONTAINING SILICA PARTICLES:</p> <ul style="list-style-type: none"> • This dust can cause serious injury to the lungs under some exposure levels. • Be aware of and follow the OSHA (or other regulatory body) guidelines for exposure to airborne crystalline silica. • To meet OSHA silica guidelines, use appropriate Personal Protective Equipment and dust abatement systems, such as waterspray systems.

(3) Part No. TC650-6597-1

(4) Part No. RC488-5737-1

<p>California Proposition 65</p> <p>⚠ WARNING ⚠</p> <p>Engine exhaust, some of its constituents, certain vehicle components and fluids, contain or emit chemicals known to the State of California to cause cancer and birth defects or other reproductive harm.</p>

<p>⚠ WARNING</p> <p>TO AVOID PERSONAL INJURY OR DEATH :</p> <p>STOP Do not open engine hood before stopping engine.</p> <p>Only when engine does not stop with the key, Pull back this stop button and hold it until the engine stops.</p>

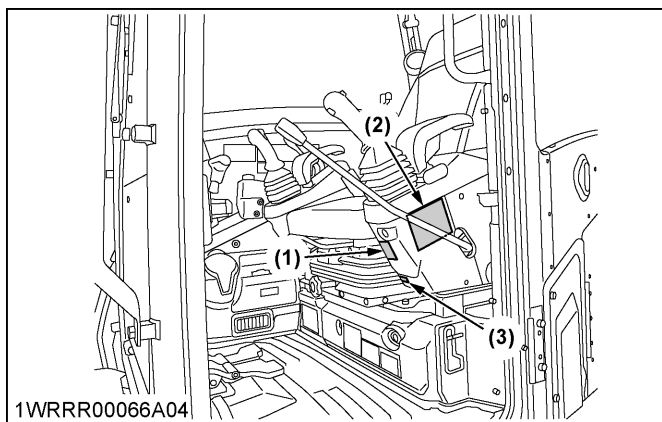

(1) Part No. RC488-5753-1

(2) Part No. RC488-5763-1



(3) Part No. RD579-5755-1

Never put your hands and fingers in the gap under the left console.

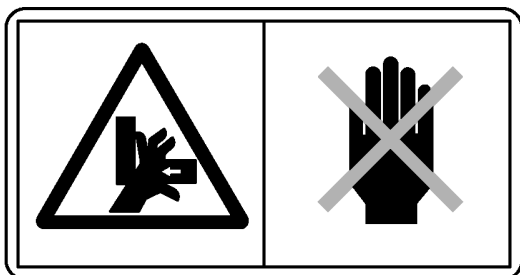

⚠️ SAFE OPERATION

[Canopy]

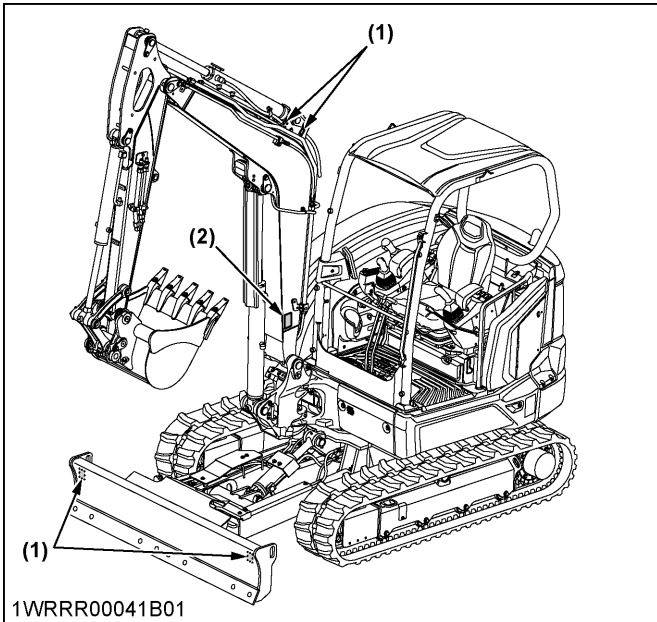

[CAB]

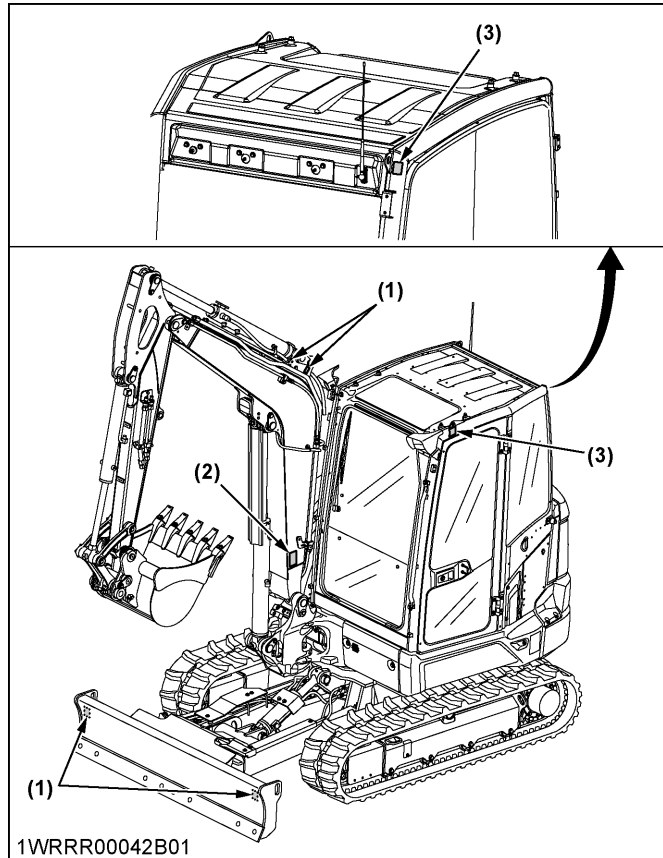

(1) Part No. RC108-5796-1
Lifting position

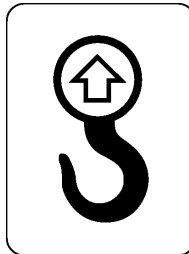

(3) Part No. RB419-5796-2

Prohibited for use in lifting the machine

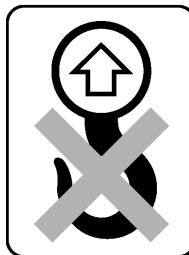

[Canopy]

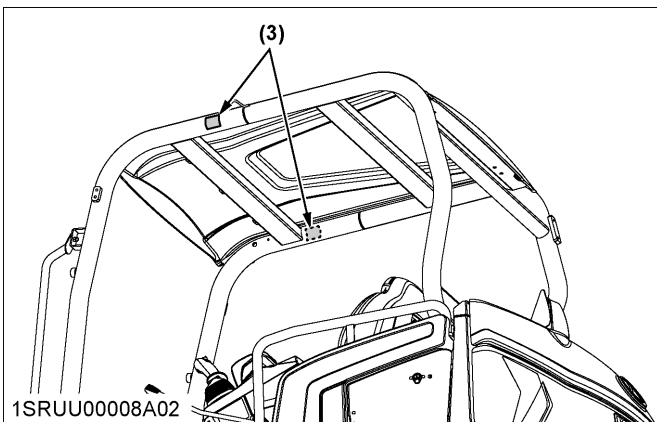

(2) Part No. 68328-5735-1 (both sides)

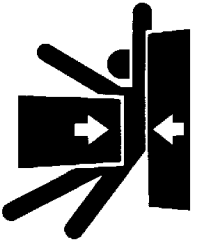

⚠️ WARNING

BOOM PINCH POINTS:
Keep out of this area to avoid serious personal injury or death.

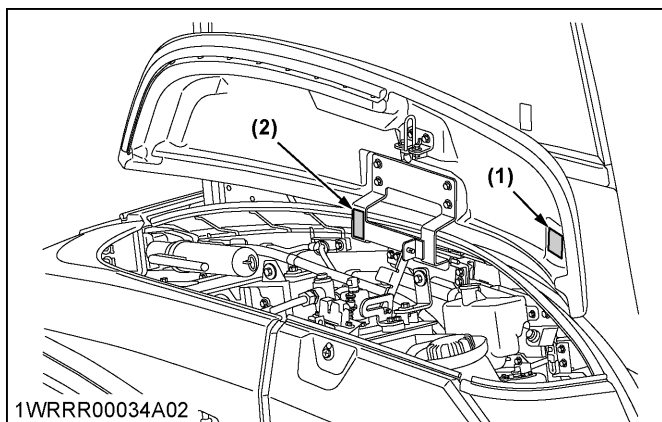

(1) Part No. RD578-5736-1

Diesel fuel only No fire

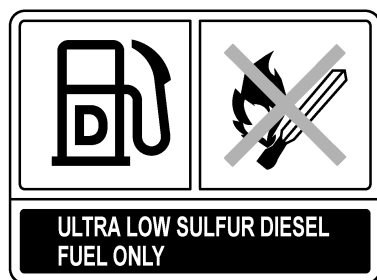

(2) Part No. RD579-5724-1

Release the pressure in the hydraulic tank before performing maintenance.

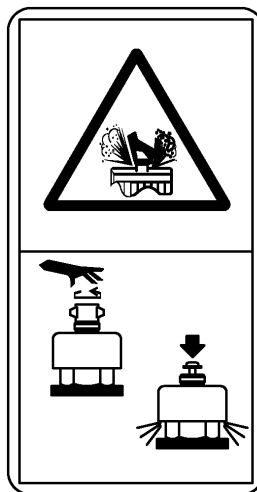

⚠️ SAFE OPERATION

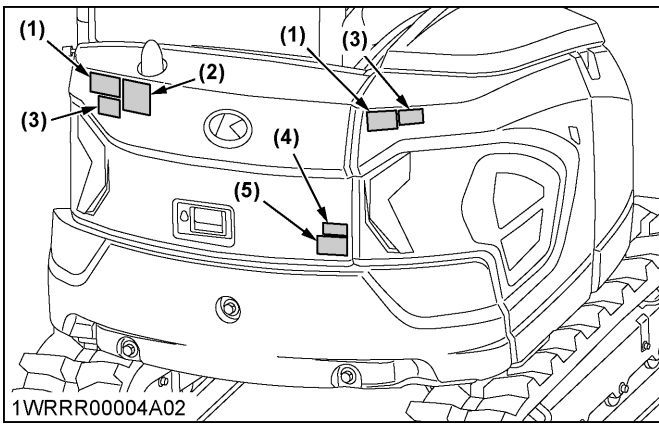

(1) Part No. RC788-5727-2

When the machine swivels, there is a risk of being crushed by the upper rotating body.
Do not stand within the machine's working range.

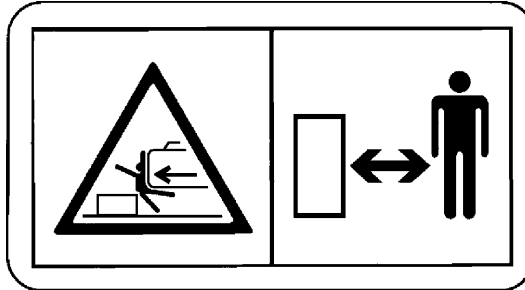

(2) Part No. 3S205-9868-1

⚠️ WARNING

TO AVOID PERSONAL INJURY OR DEATH:
When the Diesel Particulate Filter (DPF) is in the regenerating mode, the exhaust gas and the DPF muffler become hot.
During regeneration, take into account that the muffler will be very hot and keep the machine away from other people, animals, plants, and flammable material.
Also keep the area near the DPF muffler clean and away from flammable material.

(3) Part No. RD148-7687-1
[6-in-1 blade type]

⚠️ WARNING

BLADE PINCH POINTS:
Keep out of this area to avoid serious personal injury or death.

(4) Part No. RC488-5714-1

⚠️ WARNING

TO AVOID PERSONAL INJURY OR DEATH
NEVER OPEN BEFORE STOPPING ENGINE

(5) Part No. RD578-5718-1

⚠️ DANGER

TO AVOID PERSONAL INJURY OR DEATH FROM A MACHINE RUNAWAY.

1. Do not start engine by shorting across starter terminals.
2. Start engine only from operator's seat.

! SAFE OPERATION

[CAB]

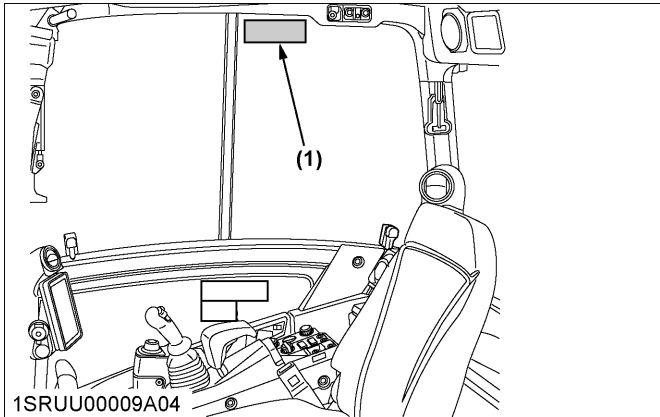

[Canopy]

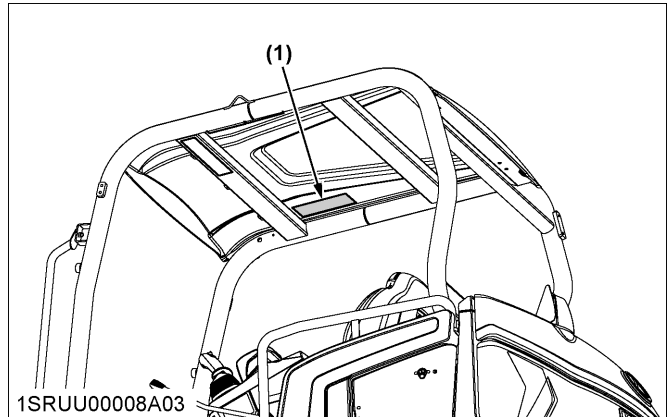

(1) Part No. RD188-5747-1

! WARNING

TO AVOID PERSONAL INJURY OR DEATH:

- Do not move raised load over people.
- It is forbidden to lift loads greater than those values mentioned in the lifting capacity tables.
- The values mentioned in the table are valid only on even, hard grounds. When lifting on soft ground, the machine can tilt over due to the fact that the load is concentrated only on one side of the machine.
- The table values are calculated at the end of the arm without the bucket. In order to find the allowable loads for machines with bucket, the bucket weight must be subtracted from the values in the table.

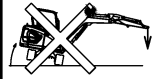

- The lifting capacities are based on ISO 10567 and do not exceed 75% of the static tilt load of the machine or 8% of the hydraulic lifting capacity of the machine.
- The strokes are as follows.
 - The load point corresponds to the front bolt part of the arm.
 - The machine positions are (i) over-front (Blade down), (ii) over-front (Blade up), and (iii) over-side.
 - The operating cylinder is the boom cylinder.
- The bucket of the excavator, the hook, the sling and other lifting accessories are taken into consideration for the loads.

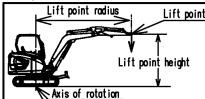







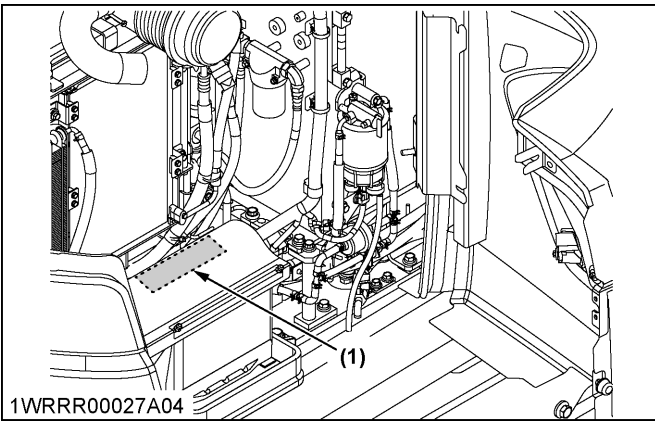



LIFT POINT HEIGHT (ft)	LIFTING CAPACITY OVER-FRONT BLADE DOWN Unit=1000lbs					LIFTING CAPACITY OVER-FRONT BLADE UP Unit=1000lbs					LIFTING CAPACITY OVER-SIDE Unit=1000lbs				
	LIFT POINT RADIUS(ft)					LIFT POINT RADIUS(ft)					LIFT POINT RADIUS(ft)				
	MIN	6	10	14	MAX	MIN	6	10	14	MAX	MIN	6	10	14	MAX
12															
8			1.79	1.66	1.67			1.79	1.41	1.26			1.79	1.26	1.12
4			2.60	1.87	1.72			2.24	1.37	1.16			1.96	1.22	1.03
0	2.46	3.12	2.03	1.80	2.46	2.15	1.34	1.20	2.46	1.88	1.19	1.06			
-4	3.28	5.55	2.94		3.28	5.05	2.15		3.28	4.17	1.88				
-8	2.88				2.88				2.88						

Machine with ROPS canopy and rubber track, without bucket.



⚠️ SAFE OPERATION



(1)

⚠️ DANGER / POISON			
SHIELD EYES. EXPLOSIVE GASES CAN CAUSE BLINDNESS OR INJURY.  	NO SPARKS, FLAMES, SMOKING  	SULFURIC ACID CAN CAUSE BLINDNESS OR SEVERE BURNS.  	FLUSH EYES IMMEDIATELY WITH WATER. GET MEDICAL HELP FAST. 
 KEEP OUT OF THE REACH OF CHILDREN.	 READ INSTRUCTIONS.	DO NOT TIP. DO NOT OPEN.	
CALIFORNIA PROPOSITION 65 <small>⚠️ WARNING: THIS PRODUCT CAN EXPOSE YOU TO CHEMICALS INCLUDING LEAD, WHICH IS KNOWN TO THE STATE OF CALIFORNIA TO CAUSE CANCER AND BIRTH DEFECTS OR OTHER REPRODUCTIVE HARM. FOR MORE INFORMATION GO TO WWW.P65WARNINGS.CA.GOV</small>			
		90D26L 52 Ah (5HR) 65 Ah (20HR) 12V RC125 (MIN) 680 CCA (SAE) 680 CCA (EA)	

S.O.C Indicator

 OK
  Charge
  Replace

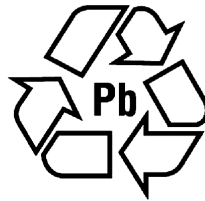

BATTERY MUST BE RECYCLED

Clarios Delkor Corporation :
 13, Okgye2gongdan-ro, Gumi-si,
 Gyeongsangbuk-do, Korea. Rep
www.delkor.com

 **Pb**

DK206682



Keep away cigarettes, flames or sparks.



Always shield eyes and face from battery.



Danger explosive gases.



Keep out of reach of children.



Poison causes severe burns.
Contains sulfuric acid.



Read and understand operator's manual.



Battery fluid (sulfuric acid) can cause blindness or severe burns.
If any fluid comes into contact with eyes, wash it off thoroughly with water.
If any gets in the eyes, seek immediate medical treatment.

1. Care of safety labels

- Keep safety labels clean and free from obstructing material.
- Clean safety labels with soap and water, and dry with a soft cloth.
- Replace damaged or missing safety labels with new labels from your Kubota dealer.
- If a component with safety label(s) affixed is replaced with new part, make sure new label(s) is (are) attached in the same location(s) as the replaced component.
- Mount new safety labels by applying on a clean dry surface and pressing any bubbles to outside edge.

DEALER SERVICE

Your Kubota dealer is always ready to help so that your machine offers the best performance. After having carefully read these instructions, you will realize that much of the routine maintenance can be done by yourself. For service, contact the Kubota dealer shop from which you purchased your product, or your local Kubota dealer. When ordering parts from your Kubota dealer, always mention the product identification number of the machine and the serial number of the engine.

Note these numbers right away in the space provided.

Machine product identification number	
Dealer's name (To be filled in by the owner)	
Date of purchase	

	Model	Serial number
Engine		

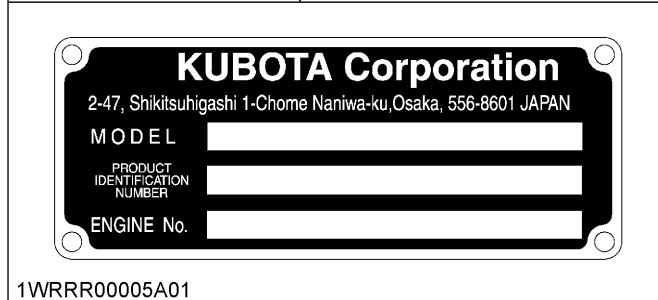
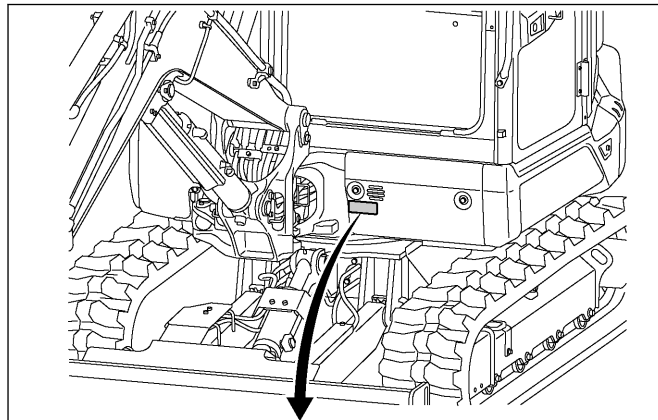

1WRRR00005A01

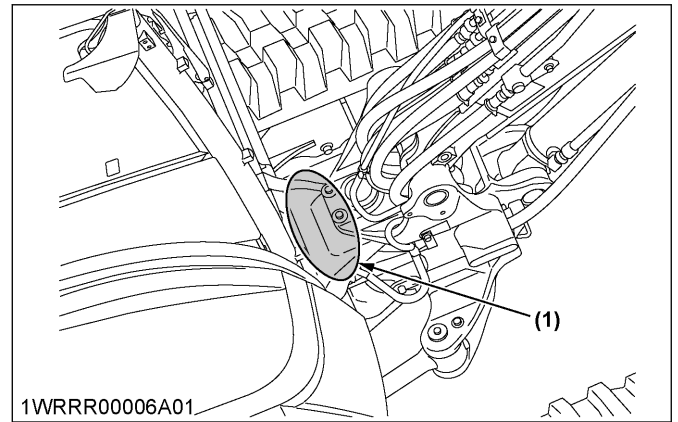

(1) Product identification number

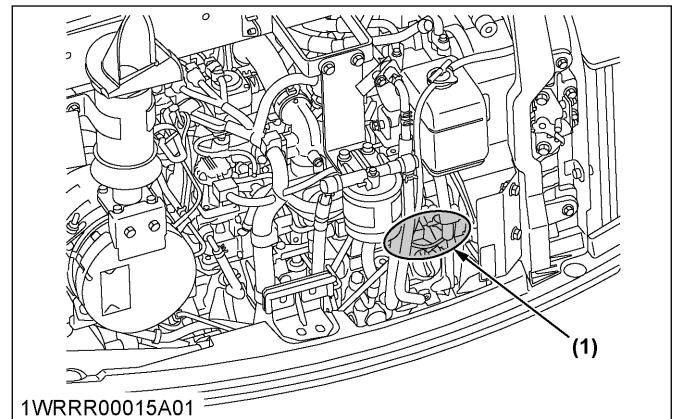

(1) Engine serial number

WARRANTY POLICY

This product is warranted under the **Kubota Limited Express Warranty**, a copy of which may be obtained from your selling dealer. No warranty shall, however, apply if the product has not been serviced and maintained according to the instructions given in the operator's manual, even if it is within the warranty period.

The product (s) described in this operator's manual are designed and manufactured only for the country in which they are initially wholesaled by Kubota or one of its affiliated companies. Neither Kubota Corporation nor its affiliated companies provide warranty for any product which is resold or retailed in any country other than the country for which the product (s) were designed or manufactured.

SCRAPPING THE PRODUCT AND ITS PROCEDURE

To put the product out of service, follow the local rules and regulations of the country or territory where you reside. If you have questions, contact your local Kubota dealer.

TECHNICAL DATA

Model		KX040-5											
Type		Rubber tracks											
		Standard Blade Type		Angle Blade Type		6-in-1 Blade Type							
		Canopy	CAB	Canopy	CAB	Canopy	CAB						
Operating weight (including operator)		kg (lbs.)	4165 (9182)	4300 (9480)	4365 (9623)	4495 (9910)	4520 (9965)	4650 (10251)					
Engine		Type						Water cooled 4 cycle diesel engine with 3 cylinder					
		Model		D1803-CR-TE5-BH5	D1803-CR-TE5-BH6	D1803-CR-TE5-BH5	D1803-CR-TE5-BH6	D1803-CR-TE5-BH5	D1803-CR-TE5-BH6				
		Total displacement		cc (cu.in)	1826 (111.4)								
		Engine power		SAE J1995 gross		kW (HP)		30.1 (40.4)					
				SAE J1349 net		kW (HP)		29.2 (39.1)	29.0 (38.9)	29.2 (39.1)	29.0 (38.9)	29.2 (39.1)	29.0 (38.9)
				ISO14396		kW (HP)		29.7 (39.8)					
		Rated speed		rpm	2200								
		Low idle speed		rpm	1150								
Performance		Swivel speed		rpm	9.2								
		Travel speed		Fast	km/h (mph)	5.0 (3.1)							
				Slow	km/h (mph)	2.7 (1.7)							
		Ground pressure		ISO 16754		kPa (kgf/cm ²) [psi]	31.2 (0.317) [4.51]	32.1 (0.327) [4.66]	32.6 (0.332) [4.73]	33.6 (0.343) [4.87]	33.8 (0.345) [4.90]	34.8 (0.355) [5.05]	
				Max. climbing angle		% (deg)	58 (30) ^{*1*2*3*4}						
Dozer		Width × height		mm (in.)	1700 × 350 (66.9 × 13.8)		1700 × 385 (66.9 × 15.2)		1800 × 385 (70.9 × 15.2)				
		Max swing angle		Left	rad (deg)	—		0.44 (25)					
				Right	rad (deg)	—		0.44 (25)					
		Max tilt angle		Left	rad (deg)	—				0.17 (10)			
Right	rad (deg)			—				0.17 (10)					
Boom swing angle		Left	rad (deg)	1.20 (70)									
		Right	rad (deg)	0.96 (55)									
Pressure connection for attachments		Maximum displacement (theoretical)		L (U.S.gals)/ min	65 (17) (AUX 1 port) 37 (9.8) (AUX 2 port)								
		Maximum pressure		kPa (kgf/cm ²) [psi]	17.2 (175) [2500] (AUX 1 port) 17.2 (175) [2500] (AUX 2 port)								
Fuel tank capacity		L (U.S.gals)	66 (17.4)										

*1 With unloaded digging bucket

*2 Firm compacted soil

*3 Operators must exercise extra caution and follow the instructions in the operator's manual.

*4 Worse conditions or heavier attachments than those listed will decrease the climbing angle.

NOTE :

- The performances are based on the machine with quick attach coupler (K7870A) and quick attach bucket (K7875A).
- These specifications are subject to change without notice.
- ROPS/OPG (Top Guard Level I) structure complies with ISO 3471, ISO 10262 and OSHA regulations.

Model		KX040-5							
Type		Steel tracks							
		Standard Blade Type		Angle Blade Type		6-in-1 Blade Type			
		Canopy	CAB	Canopy	CAB	Canopy	CAB		
Operating weight (including operator) kg (lbs.)		4240 (9348)	4375 (9645)	4435 (9777)	4570 (10075)	4590 (10119)	4725 (10417)		
Engine	Type	Water cooled 4 cycle diesel engine with 3 cylinder							
	Model	D1803-CR-TE5-BH5	D1803-CR-TE5-BH6	D1803-CR-TE5-BH5	D1803-CR-TE5-BH6	D1803-CR-TE5-BH5	D1803-CR-TE5-BH6		
	Total displacement	cc (cu.in) 1826 (111.4)							
	Engine power	SAE J1995 gross	kW (HP) 30.1 (40.4)						
		SAE J1349 net	29.2 (39.1)	29.0 (38.9)	29.2 (39.1)	29.0 (38.9)	29.2 (39.1)	29.0 (38.9)	
		ISO14396	kW (HP) 29.7 (39.8)						
	Rated speed	rpm 2200							
Low idle speed	rpm 1150								
Performance	Swivel speed	rpm 9.2							
	Travel speed	Fast	km/h (mph) 5.0 (3.1)						
		Slow	km/h (mph) 2.7 (1.7)						
	Ground pressure	ISO 16754	kPa	31.5	32.5	32.9	33.9	34.1	35.1
			(kgf/cm ²) [psi]	(0.321) [4.57]	(0.331) [4.71]	(0.335) [4.77]	(0.346) [4.92]	(0.348) [4.95]	(0.358) [5.09]
Max. climbing angle	% (deg) 58 (30) ^{*1*2*3*4}								
Dozer	Width × height		mm (in.) 1700 × 350 (66.9 × 13.8)		1700 × 385 (66.9 × 15.2)		1800 × 385 (70.9 × 15.2)		
	Max swing angle	Left	rad (deg) —		0.44 (25)				
		Right	rad (deg) —		0.44 (25)				
	Max tilt angle	Left	rad (deg) —			0.17 (10)			
		Right	rad (deg) —			0.17 (10)			
Boom swing angle	Left	rad (deg) 1.20 (70)							
	Right	rad (deg) 0.96 (55)							
Pressure connection for attachments	Maximum displacement (theoretical)	L (U.S.gals)/ min 65 (17) (AUX 1 port) 37 (9.8) (AUX 2 port)							
	Maximum pressure	kPa (kgf/cm ²) [psi] 17.2 (175) [2500] (AUX 1 port) 17.2 (175) [2500] (AUX 2 port)							
Fuel tank capacity		L (U.S.gals) 66 (17.4)							

*1 With unloaded digging bucket

*2 Firm compacted soil

*3 Operators must exercise extra caution and follow the instructions in the operator's manual.

*4 Worse conditions or heavier attachments than those listed will decrease the climbing angle.

NOTE :

- The performances are based on the machine with quick attach coupler (K7870A) and quick attach bucket (K7875A).
- These specifications are subject to change without notice.
- ROPS/OPG (Top Guard Level I) structure complies with ISO 3471, ISO 10262 and OSHA regulations.

EXCAVATOR PARTS

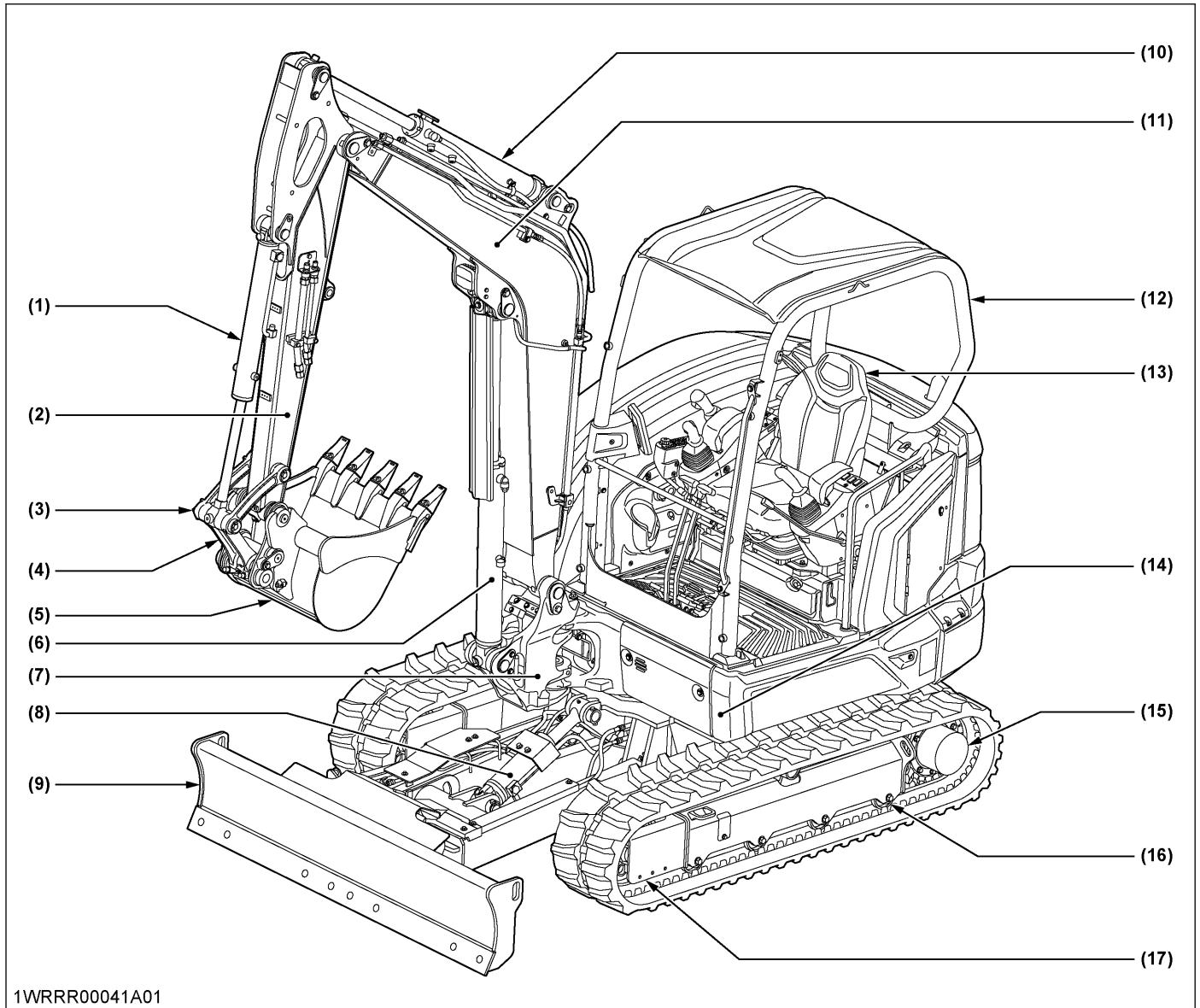

1WRRR00041A01

- (1) Bucket cylinder
- (2) Arm
- (3) Bucket link 2 and 3
- (4) Bucket link 1
- (5) Bucket

- (6) Boom cylinder
- (7) Swing bracket
- (8) Dozer cylinder
- (9) Dozer blade
- (10) Arm cylinder

- (11) Boom
- (12) Canopy
- (13) Seat
- (14) Swivel frame
- (15) Drive sprocket

- (16) Track roller
- (17) Front idler

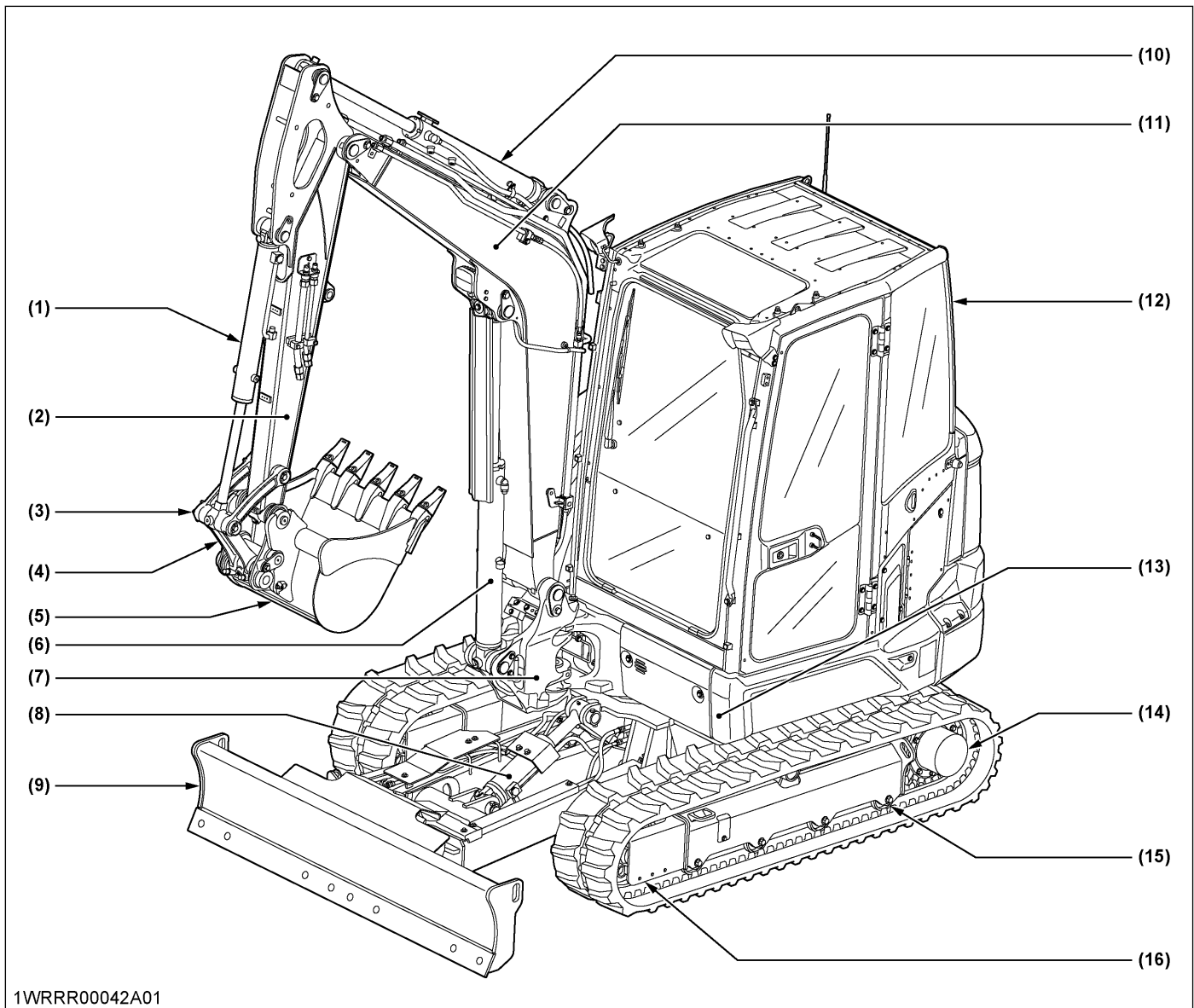

1WRRR00042A01

- | | | | |
|-------------------------|--------------------|-------------------|---------------------|
| (1) Bucket cylinder | (5) Bucket | (9) Dozer blade | (13) Swivel frame |
| (2) Arm | (6) Boom cylinder | (10) Arm cylinder | (14) Drive sprocket |
| (3) Bucket link 2 and 3 | (7) Swing bracket | (11) Boom | (15) Track roller |
| (4) Bucket link 1 | (8) Dozer cylinder | (12) CAB | (16) Front idler |

[6-in-1 blade type]

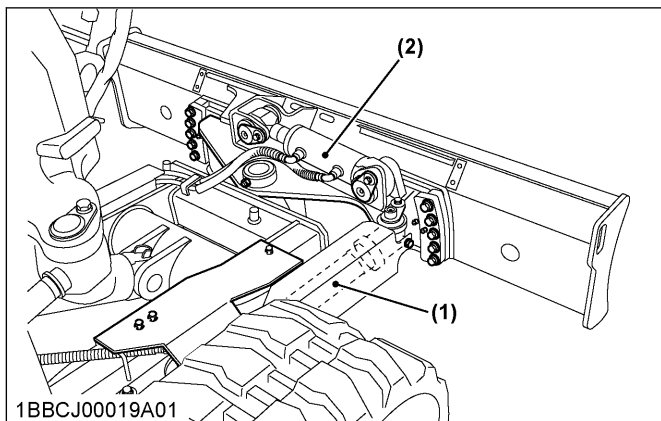

1BBCJ00019A01

- | |
|--------------------|
| (1) Angle cylinder |
| (2) Tilt cylinder |

INSTRUMENT PANEL AND CONTROLS

INSTRUMENT PANEL AND SWITCHES

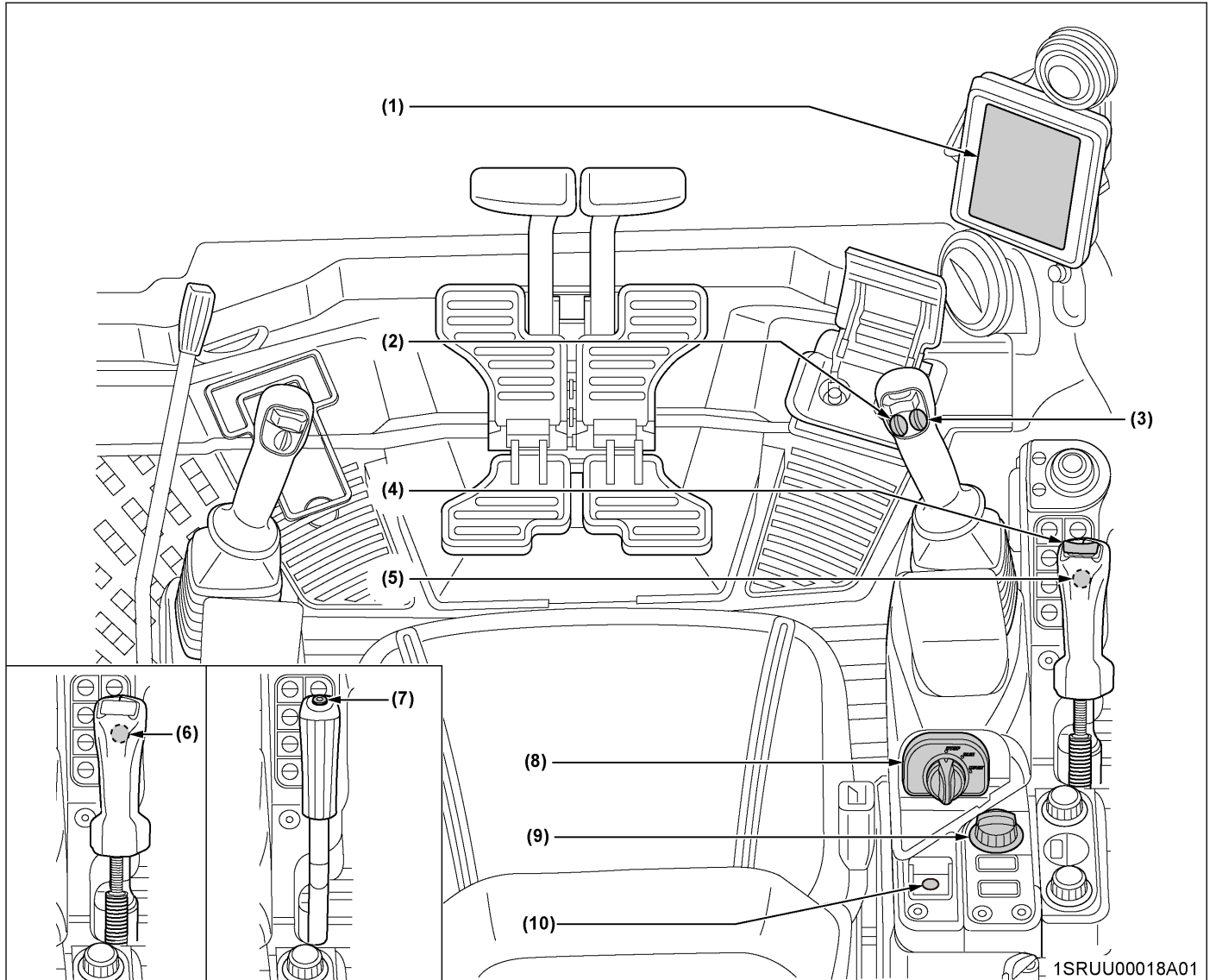

(1) Display	40	(7) Travel speed switch [Standard type]	66
(2) Horn switch	64	(8) Starter switch	40
(3) Aux port enable switch	65	(9) Throttle potentiometer	66
(4) Tilt switch [6-in-1 blade type]	101	(10) Inhibit Diesel Particulate Filter (DPF) regeneration switch (inhibit switch)	67
(5) Travel speed switch [6-in-1 blade type]	66		
(6) Travel speed switch [Angle blade type]	66		

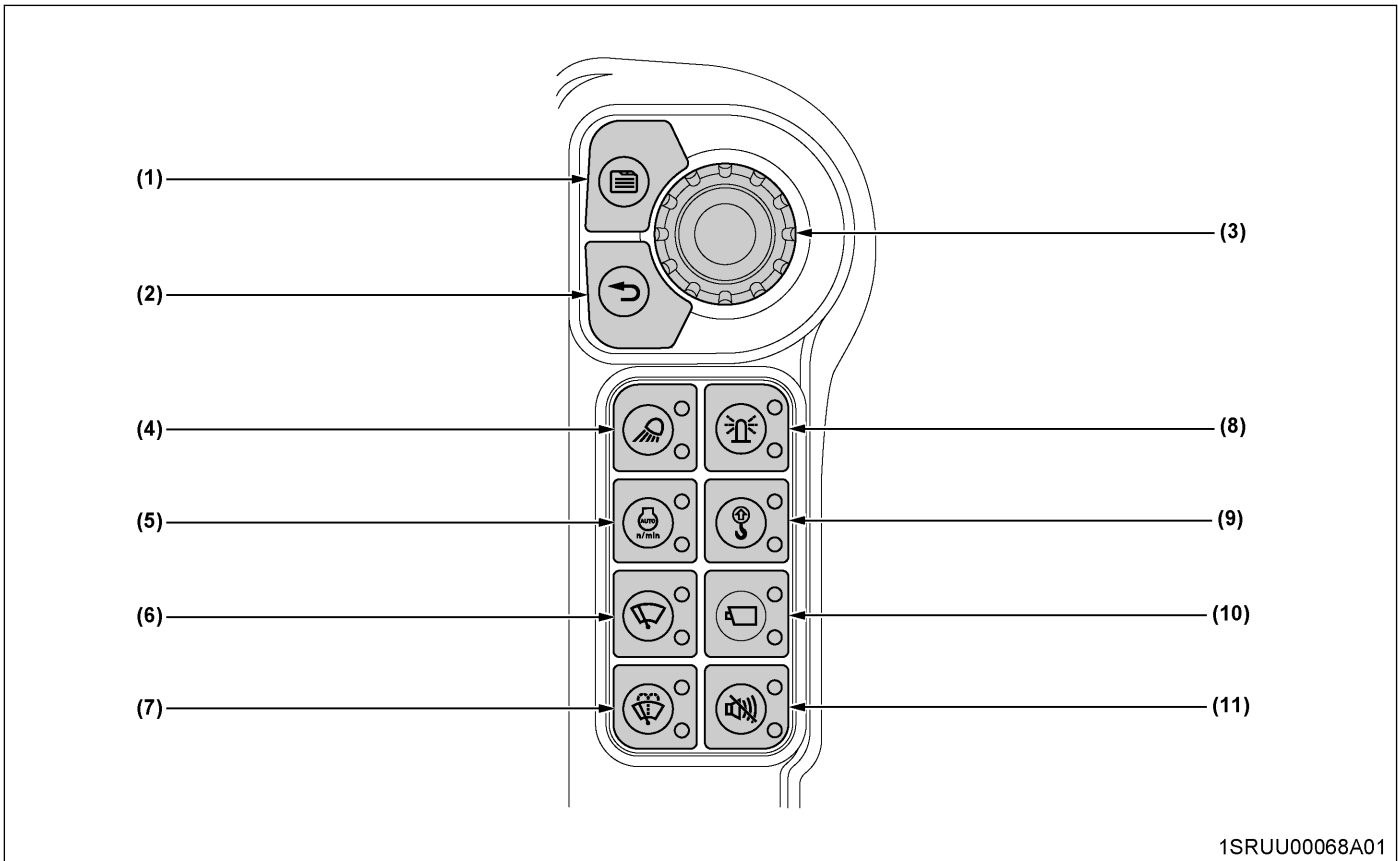

- (1) Menu switch
- (2) Return switch
- (3) Jog dial
- (4) Light switch
- (5) Auto idle control switch
- (6) Wiper switch

- (7) Washer switch
- (8) Beacon light switch
- (9) -
- (10) Camera switch (option)
- (11) Travel alarm cancel switch (option)

[Canopy]

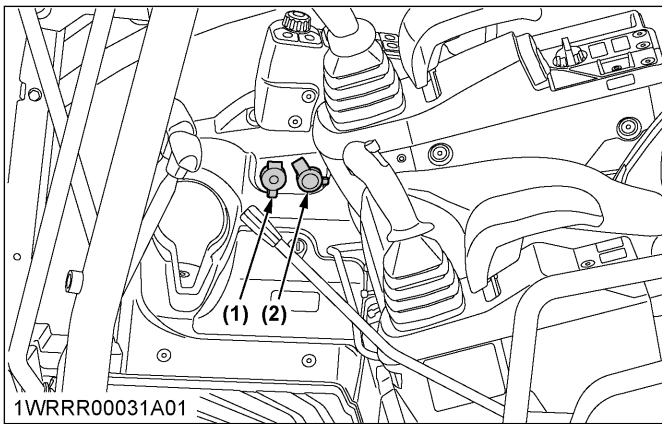

- (1) Electrical outlet
- (2) USB (Type-A) outlet

[CAB]

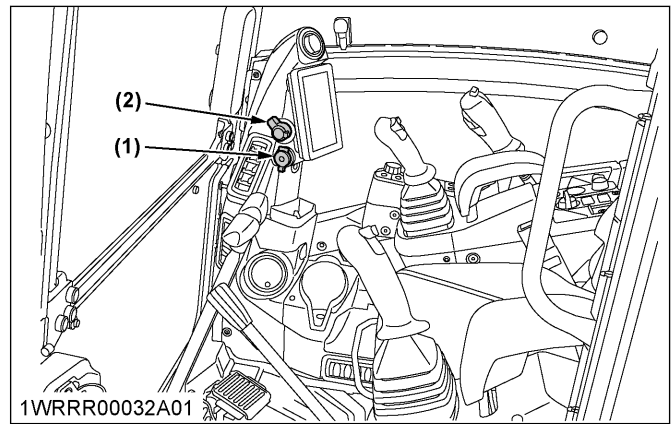

- (1) Electrical outlet
- (2) USB (Type-A) outlet

Home screen

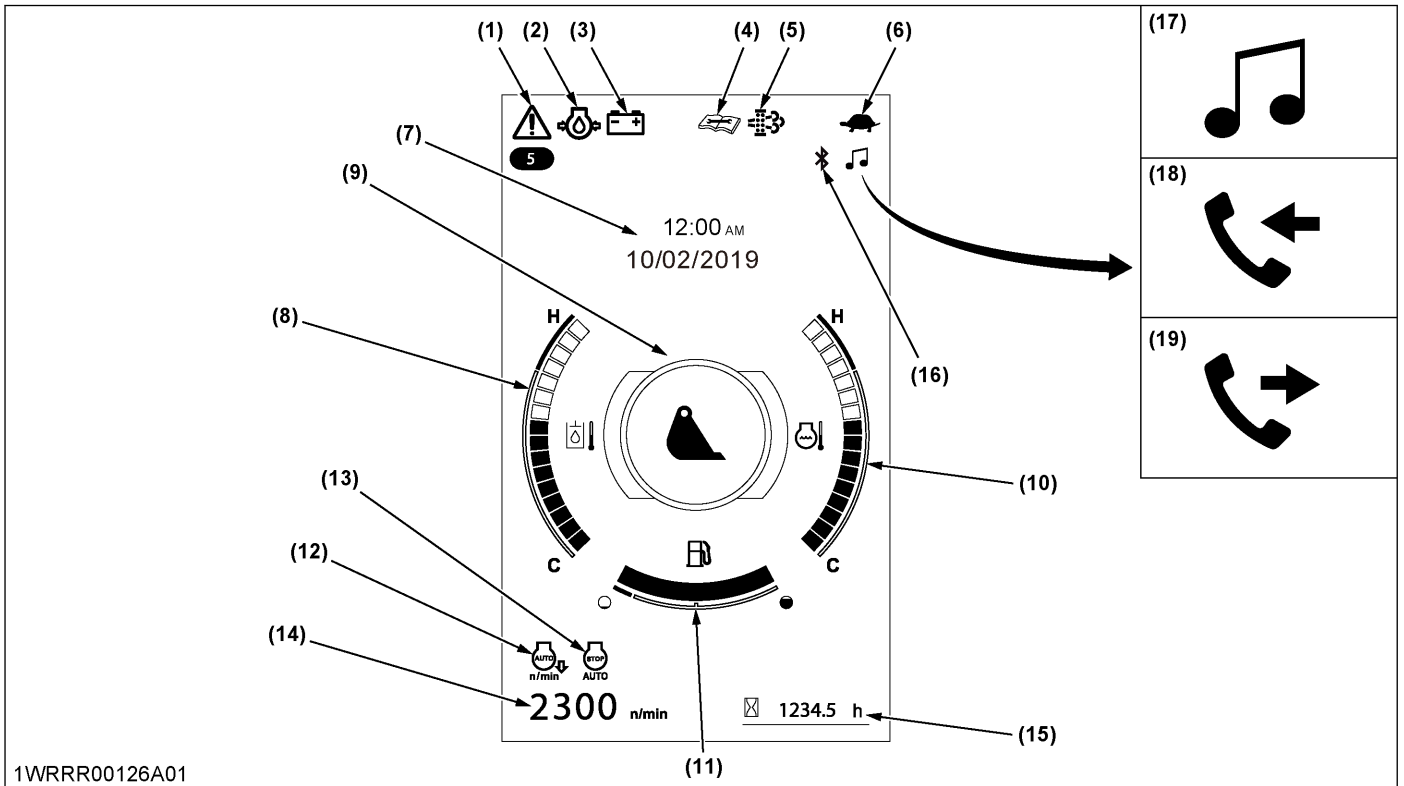

1WRRR00126A01

- (1) Warning lamp
- (2) Engine oil pressure warning lamp
- (3) Battery charging warning lamp
- (4) Periodic notification lamp
- (5) DPF regeneration lamp
- (6) Travel speed lamp
- (7) Time and date
- (8) Hydraulic oil temperature gauge
- (9) AUX mode
- (10) Coolant temperature gauge

- (11) Fuel gauge
- (12) AI lamp
- (13) Engine auto-stop lamp
- (14) Engine speed
- (15) Hour meter
- (16) Bluetooth
- (17) Audio
- (18) Incoming call
- (19) In a call

HANDLING THE INSTRUMENT PANEL AND SWITCHES

1. Starter switch

[STOP]

- The engine is stopped and the electrical parts cannot be used.

[RUN]

- Turn the starter switch one click from the [STOP] position to the [RUN] position. All the circuitry gets energized to start preheating. The message "Preheating" appears on-screen.
When checking for any lamp breakage, keep in mind that the lamp lights up and stays on for about 1 second.
- When the "Enter password" screen appears on the display, enter the 4-digit user password using the keypad.
(For details on entering user passwords, see STARTING THE ENGINE on page 79.)

[START]

- Move the pilot control lock lever to the LOCK position. Turn the starter switch one more click from the [RUN] position to the [START] position. The starter motor is then activated to start the engine. When you let go of the starter switch, the starter switch returns to the [RUN] position. Therefore, once the engine has started, let go of the starter switch.

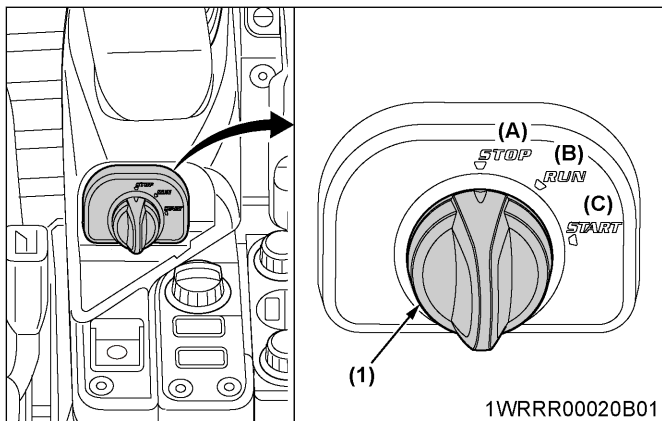

(1) Starter switch

- (A) STOP
- (B) RUN
- (C) START

NOTE :

- Even when the machine is off, press the jog dial, and the display shows the hour meter, fuel gauge, water temperature gauge, hydraulic oil temperature gauge, and clock for 10 seconds.

2. Display for normal operation

IMPORTANT :

- When cleaning the display screen, wipe with a soft cloth like those used for cleaning eyeglasses.
- Using a coarse cloth or rubbing too hard may damage the surface.
- Cleaning the display screen with alkaline, acidic, or organic solvents such as alcohol or benzene can damage the screen.

2.1 Fuel gauge

! WARNING

To avoid personal injury or death:

- Stop the engine before adding fuel.
- Keep open flames away from the machine, or it may cause a fire.
- Tighten the fuel cap after refueling.

With the starter switch at the [RUN] position, the fuel remaining in the fuel tank is indicated.

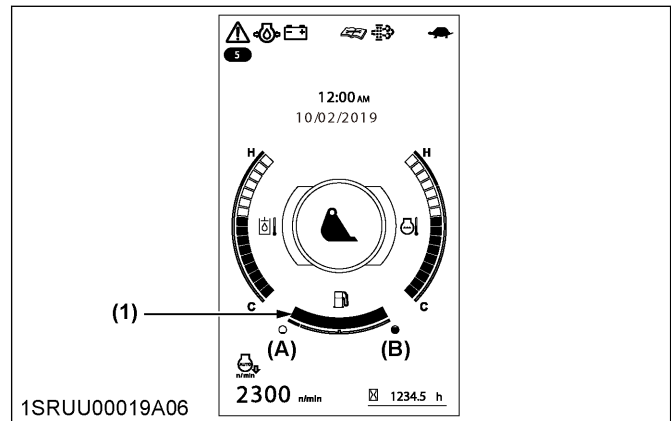

(1) Fuel gauge

- (A) EMPTY
- (B) FULL

If the fuel runs short, open the cap and refuel the tank.

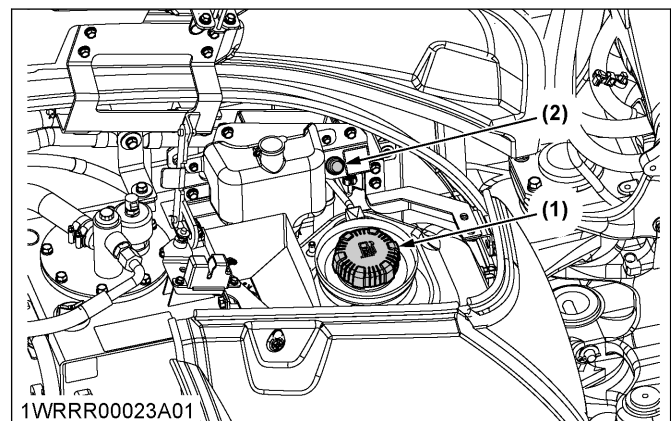

(1) Fuel cap

(2) Fuel level audible indication switch

IMPORTANT :

- If the fuel gauge indicator is near the “Empty”, or if the “Feed fuel” message appears, add fuel as soon as possible. If the indicator is near “Empty” and the machine is operated on a slope, the engine may run out of fuel.
- Users must take appropriate actions to insure fuel is not contaminated during the refueling operation.

2.2 Fuel level audible indication switch (when refueling)

The fueling progress can be monitored by a buzzer sound.

1. With the starter switch at the [STOP] position, press the fuel level audible indication switch.

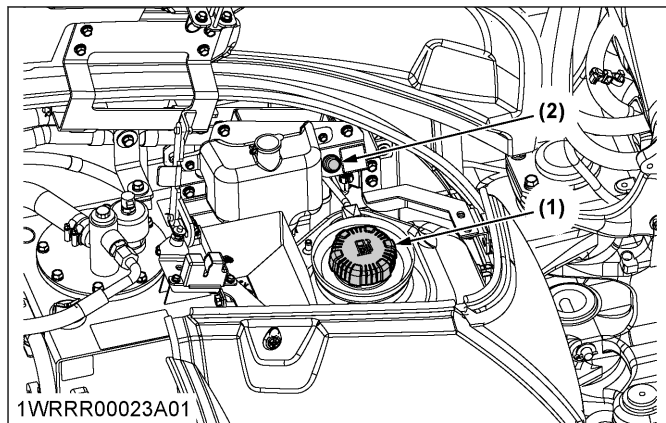

(1) Fuel cap
(2) Fuel level audible indication switch

2. Start refueling the machine. The buzzer beeping intervals change according to how much fuel is poured into the tank. As the fuel tank is filled up, the buzzer sound becomes almost continuous.

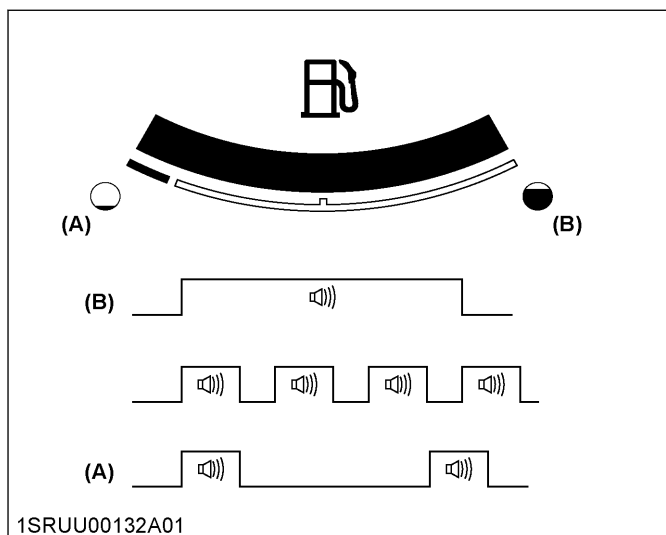

(A) EMPTY
(B) FULL

3. While refueling the machine, listen to the buzzer to know how much the fuel tank is filled.

NOTE :

- If fuel is poured too slowly, the buzzer will stop beeping. When resumed normally, the buzzer will start beeping.
4. To stop refueling halfway (before filling up), press the fuel level audible indication switch or simply stop refueling for a while. The buzzer will stop sounding.

2.3 Coolant temperature gauge

! WARNING

To avoid personal injury or death:

- Do not open the radiator cap during or just after operation. Hot coolant may gush out and scald you. Wait for the coolant to cool down before opening the cap.

The coolant temperature is indicated when the starter switch is at the [RUN] position.

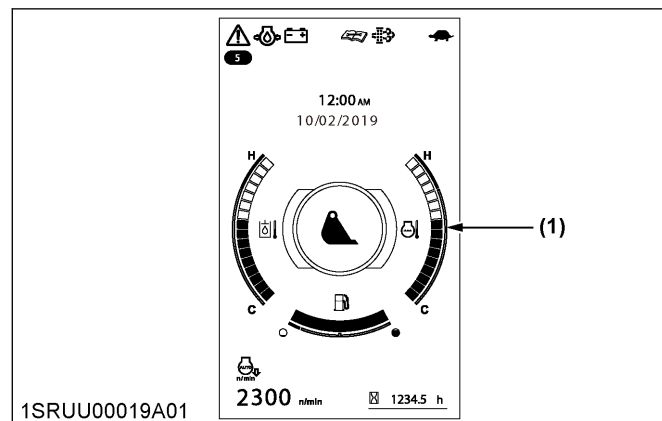

(1) Coolant temperature gauge

If the coolant temperature indicator is near [H], take the following steps. Depending on the coolant temperature, the warning message “Water temp. is rising” or “Overheat forced idling” appears. In either case, follow the same procedure:

1. Discontinue the job.
2. Reduce engine's rpm to idle and keep it at idle for 5 minutes.
3. Stop the engine and check the following points:
 - a. Low coolant level or leakage
 - b. Fan belt tension
 - c. Mud or dust deposits on radiator
 - d. Hydraulic oil leakage

2.4 Overheat warning

- If the coolant temperature becomes too high, the message “Water temp. is rising” appears on-screen for a certain period of time.

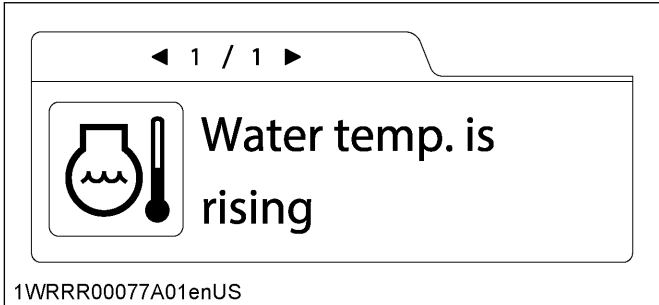

IMPORTANT :

- **If this message is displayed, interrupt the work and lower the engine rpm. This will reduce the coolant temperature.**
- The overheat warning appears on-screen. Also, the following message shows up on the display and the engine automatically starts idling. Acceleration is not operative.

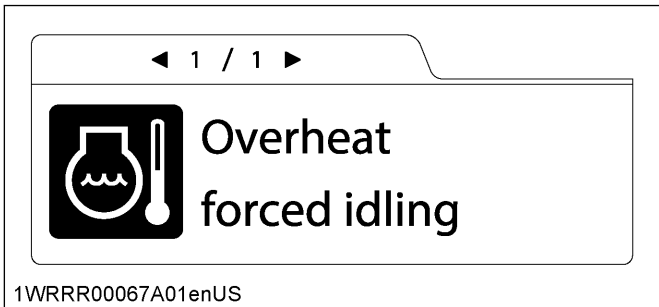

If this message appears, take corrective measures. (See Overheating countermeasures on page 83.)

NOTE :

- **Acceleration can be automatically enabled when the coolant temperature has dropped.**

2.5 Hydraulic oil temperature gauge

The hydraulic oil temperature is indicated when the starter switch is in the **[RUN]** position.

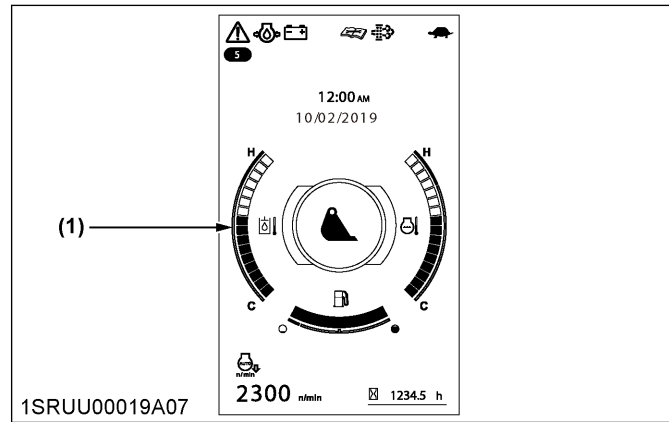

(1) Hydraulic oil temperature gauge

If the hydraulic oil temperature indicator is near “H”, take the following steps. Depending on the coolant temperature, the warning message “Hyd. oil temp. is rising” or “Overheat forced idling” appears. In either case, follow the same procedure:

1. Discontinue the job.
2. Reduce engine's rpm to idle and keep it at idle for 5 minutes.
3. Stop the engine and check the following points.
 - a. Low hydraulic oil level or leakage
 - b. Fan belt tension
 - c. Mud or dust deposits on the oil cooler
 - d. Coolant leakage

2.6 Hydraulic oil overheat warning

If the hydraulic oil temperature becomes too high, the message “Hyd. oil temp. is rising” appears on-screen for certain period of time.

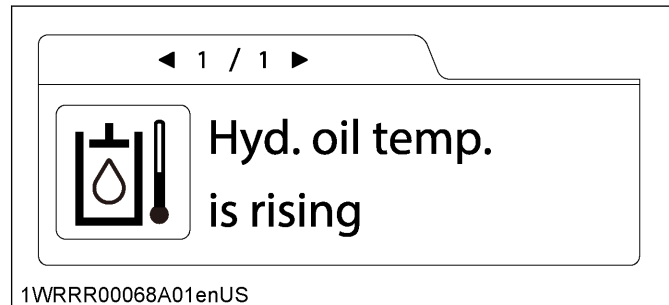

IMPORTANT :

- **If this message is displayed, interrupt the work and lower the engine rpm. This will reduce the hydraulic oil temperature.**
- **The overheat warning appears on-screen. Also, the following message shows up on the display and the engine automatically starts idling. Acceleration is not operative.**

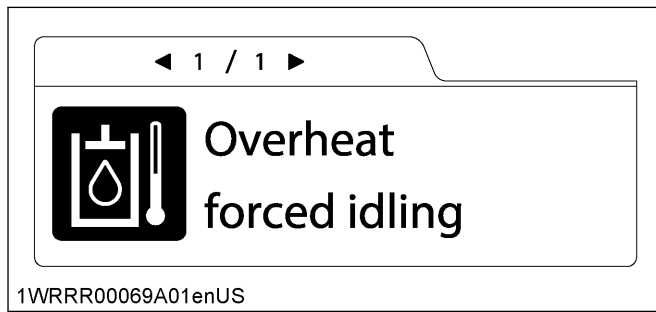

2.7 Temperature drop indication of hydraulic oil

If the hydraulic oil temperature is too low at a start of the engine, the following message appears.

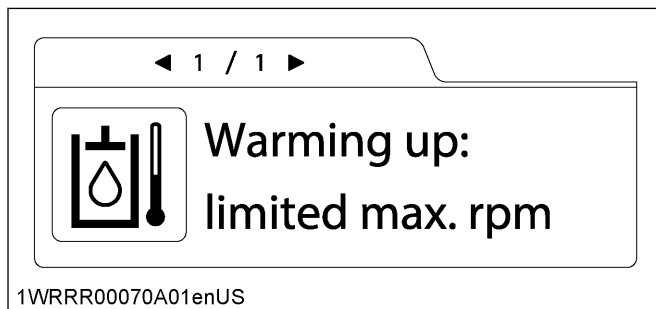

If this message appears, warm up the engine at lower than the medium speed.

(For warming-up instructions, see CHECK POINTS AFTER STARTING THE ENGINE on page 82.)

While this message is displayed, the engine rpm can only turn at up to the medium speed until the hydraulic oil temperature rises to an appropriate level.

When the hydraulic oil temperature has risen to the appropriate level, the engine rpm may be raised to maximum level accordingly by turning the throttle potentiometer.

2.8 Hour meter

The hour meter indicates the total operating hours of the machine.

How it works:

- The meter advances 1 hour after an hour of operation regardless of the engine rpm.

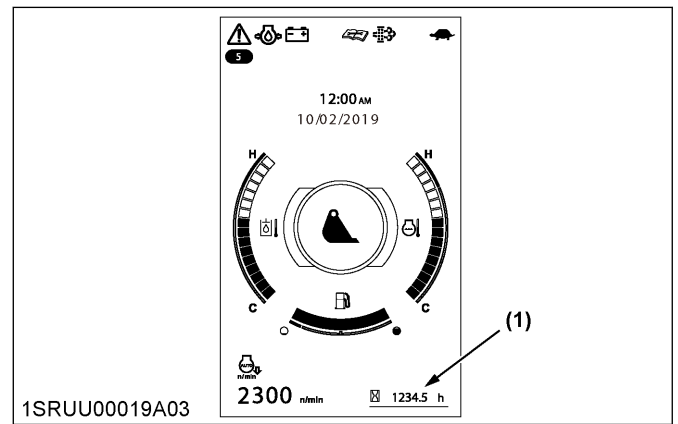

(1) Hour meter

2.9 Engine tachometer

The engine tachometer indicates the current rpm of the engine.

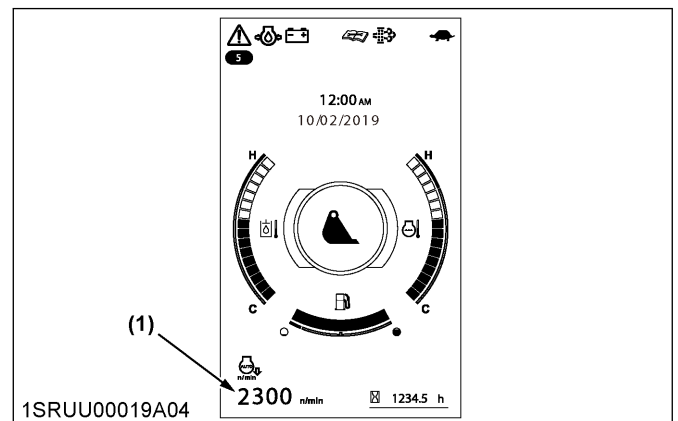

(1) Engine tachometer

2.10 Glow indication

The message "Preheating" appears on-screen when the starter switch is turned to the [RUN] position but the engine requires preheating. Wait until the message disappears, and then start the engine.

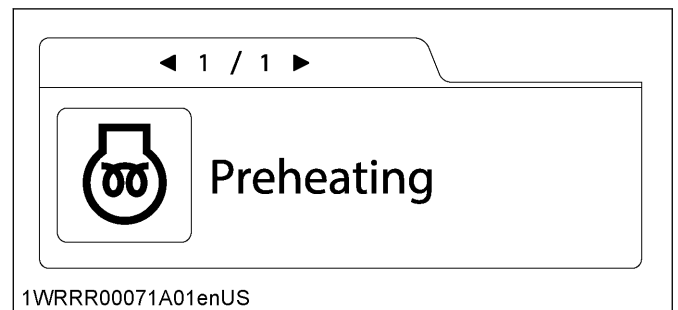

2.11 Periodic Check

The following message appears on the display 10 hours before a periodic check.

For this setting, contact your local Kubota dealer.

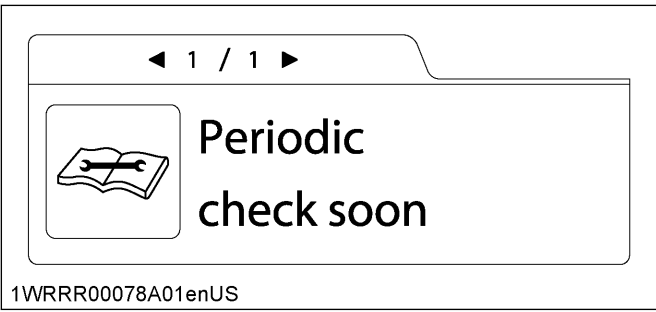

1. Press the menu switch to make the menu bar appear on-screen.
2. Rotate the jog dial to the left to select “Periodic check”, and press the jog dial to check the list of periodic check items.

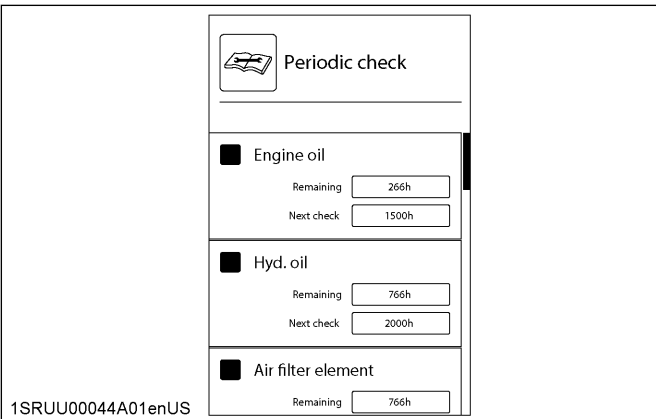
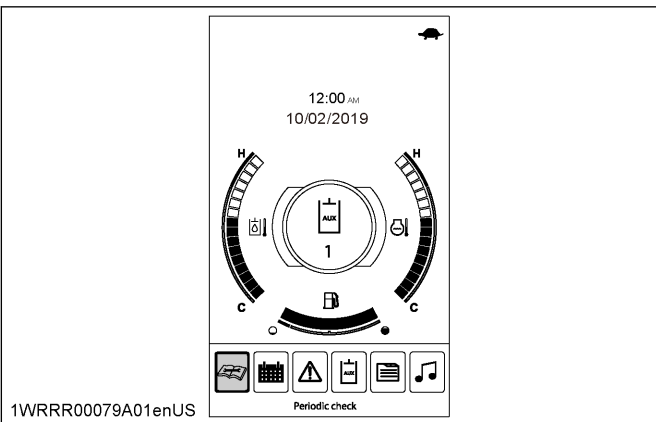

3. Perform the servicing as listed.

IMPORTANT :

- When the servicing has been completed, turn the starter switch on and off 10 times or more and the check screen automatically disappears.
- When the periodic check interval has passed, the message “Periodic check notification” shows up. Immediately perform the specified servicing.
- The periodic check screen can also be preset to only be made to disappear manually.

2.11.1 Service hour meter

When the hour meter reaches the hours circled in the following maintenance table, a message appears.

No.	Check points		Measures	Hour meter indicator									Intervals	
				50	100	250	500	600	750	1000	1500	2000		3000
1	Engine oil (CJ-4 or CK-4)		Change				○			○	○	○	○	Every 500 hrs
2	Fuel filter		Replace				○			○	○	○	○	Every 500 hrs
3	Engine oil filter						○			○	○	○	○	Every 500 hrs
4	Drive unit oil		Change	◎			○			○	○	○	○	Every 500 hrs
5	Breather filter		Replace				○			○	○	○	○	Every 500 hrs
6	Hydraulic oil		Change							○		○	○	Every 1000 hrs
7	Air filter element	Outer element	Replace							○		○	○	Every 1000 hrs
		Inner element								○		○	○	Every 1000 hrs
8	Hydraulic return filter cartridge									○		○	○	Every 1000 hrs
9	Hydraulic suction filter element									○		○	○	Every 1000 hrs
10	Pilot filter									○		○	○	Every 1000 hrs
11	Front idler and track roller oil			Change									○	

◎ represents the interval for the first servicing only.

2.12 Log record

The log record helps you check the last 3 months operating record of the machine. Take the following steps:

1. Turn the starter switch to the [RUN] position.

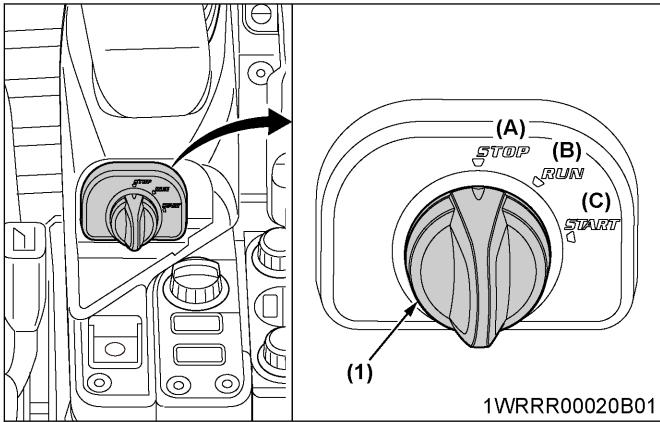

(1) Starter switch

- (A) STOP
- (B) RUN
- (C) START

2. Press the menu switch to make the menu appear on-screen.
3. Rotate the jog dial to the left to select “Log record”, and press the jog dial to make the log record (the machine's operating day and operating hours) for the current month appear.

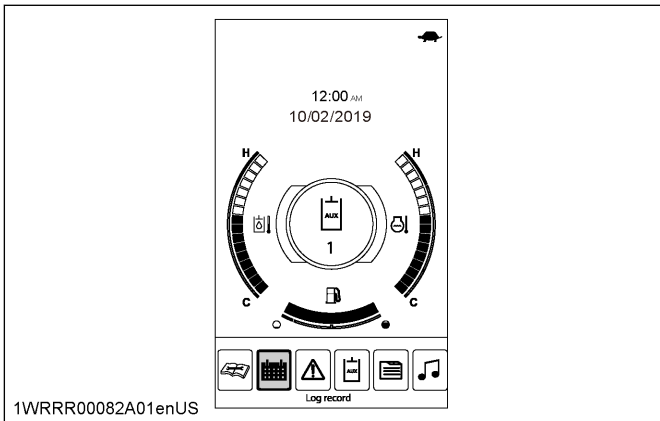

4. To view records from previous months, press the jog dial again, rotate the jog dial to select the desired month, and press the jog dial to confirm the selection.

NOTE :

- It is possible to view records from the last three months (up to 90 days ago).

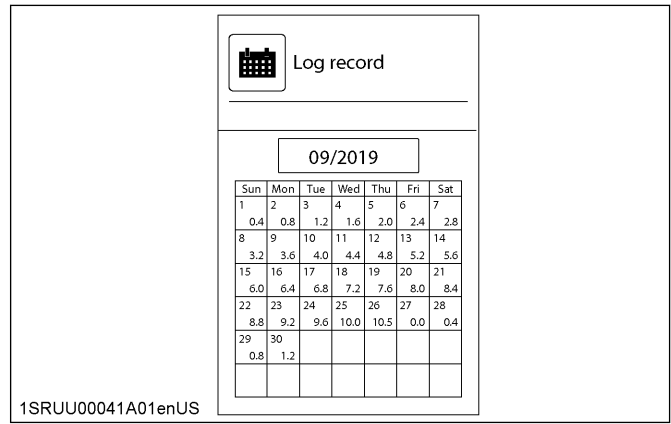

2.13 AUX settings

Details regarding AUX settings can be found in a different section. (See AUXILIARY PORT OPERATION on page 92.)

2.14 User settings

NOTE :

- If you have any questions, contact your local Kubota dealer.

2.14.1 Setting the clock

1. Turn the starter switch to the [RUN] position.

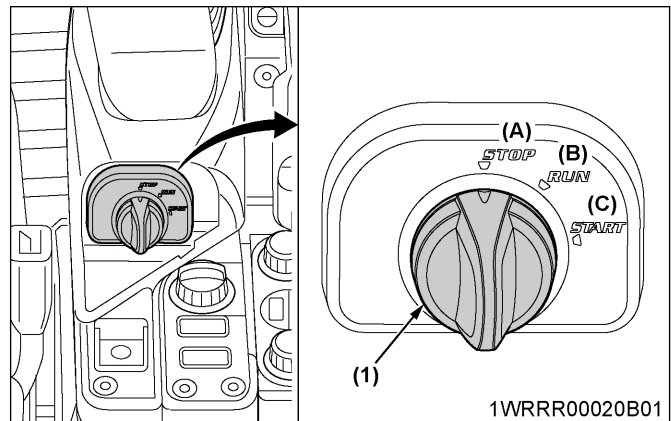

(1) Starter switch

- (A) STOP
- (B) RUN
- (C) START

2. Press the menu switch to make the menu bar appear.

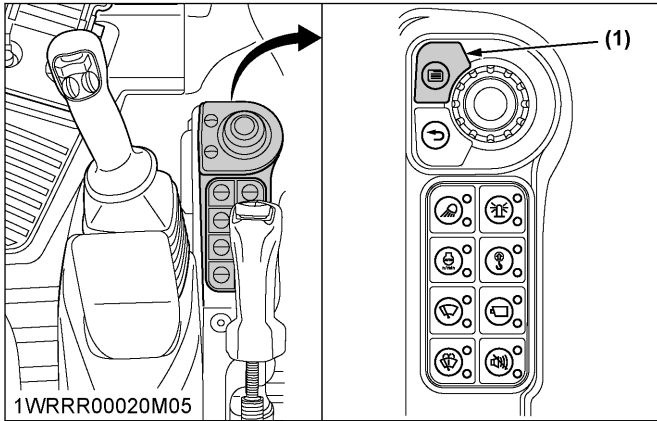

(1) Menu switch

3. Rotate the jog dial to the right to select “Various settings”, and press the jog dial.

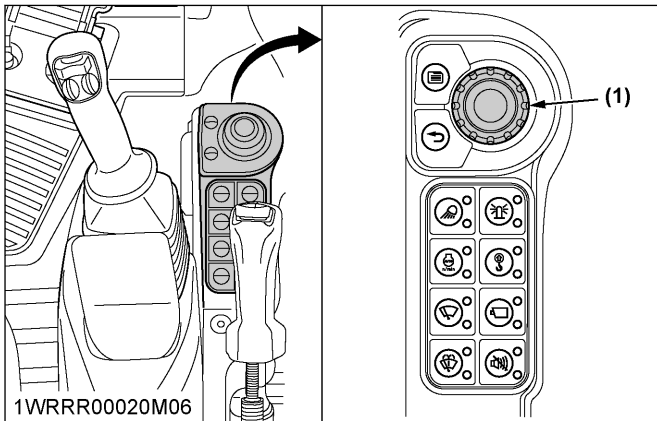

(1) Jog dial

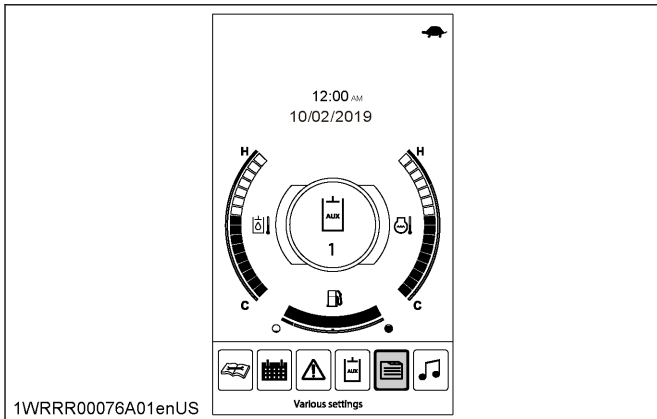

4. Rotate the jog dial to the right to select “Date & time”, and press the jog dial.

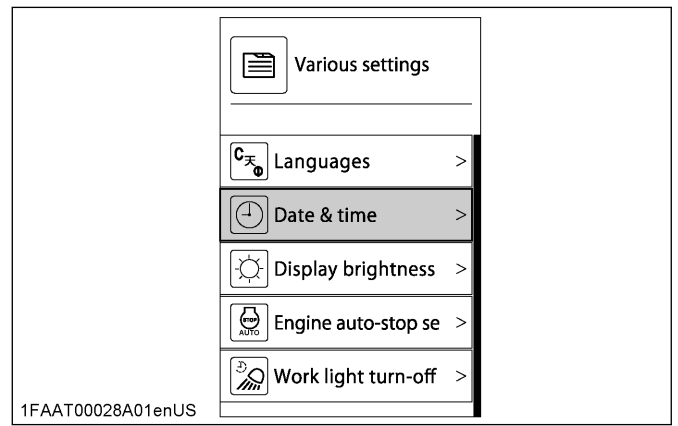

5. Rotate the jog dial to the right to select “Set date” or “Set time”, and press the jog dial.

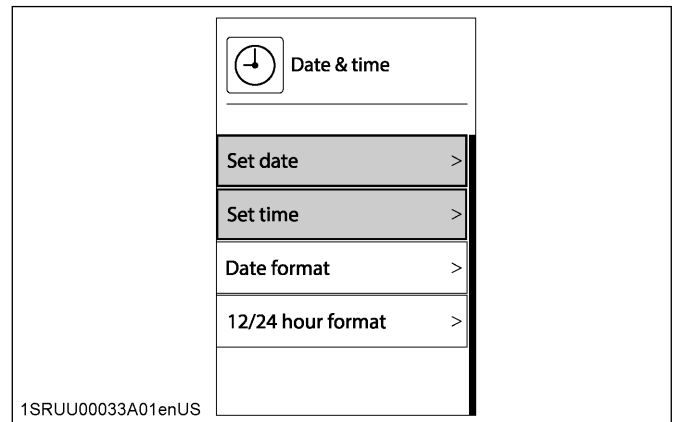

6. Adjust the numerical values as follows:

- Rotate the jog dial to the right or to the left to select the item you wish to change and press the jog dial.
- Rotate the jog dial to the right or to the left to increase or decrease the numerical value.
- Press the jog dial to confirm the value.

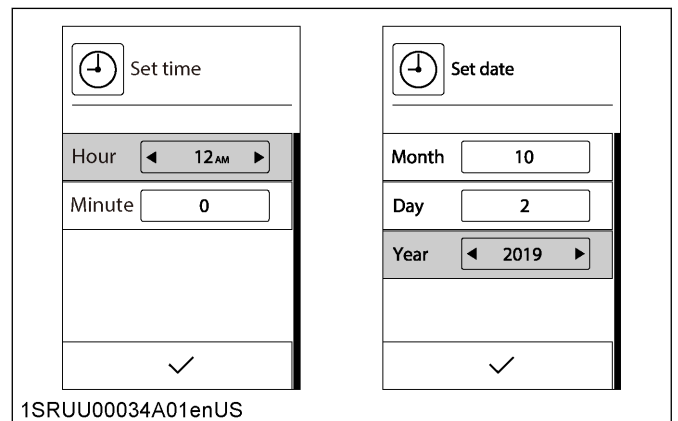

7. Rotate the jog dial to the right to select “✓” and press the jog dial to save the new settings.

NOTE :

- Be careful not to accidentally press the jog dial when “✓” is selected on the clock setting

screen. Otherwise, the seconds will be set to [00] and the clock will show the wrong time.

- If the clock is interrupted, for example when the battery is disconnected, the following message appears on-screen. Select “✓” to set the clock again.

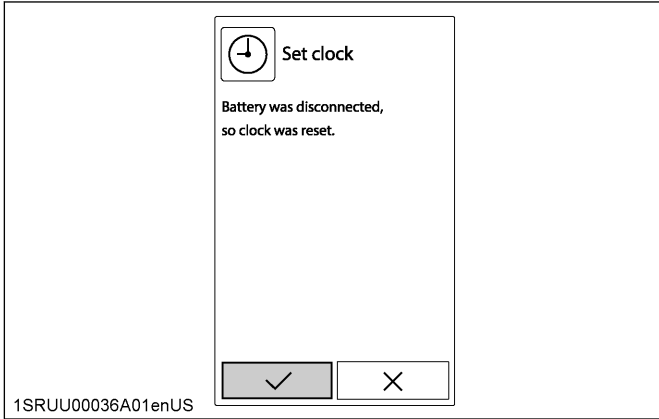

NOTE :

- When the return switch is pressed on the clock setting screen, the clock is not readjusted and returns to the previous menu screen.

2.14.2 Reordering year/month/day and selecting AM/PM or 24-hour

1. On the “Date & time” screen, select “Date format” or “12/24 format”.

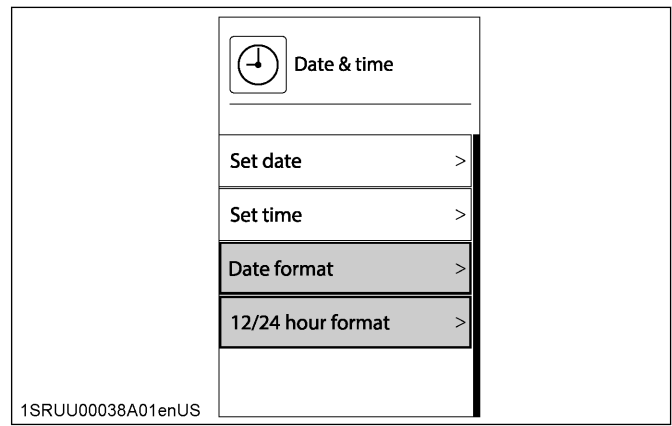
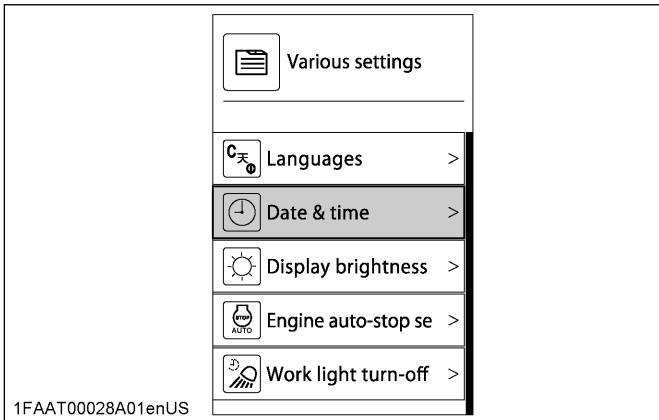

2. Press the jog dial, and one of the following screens appears.

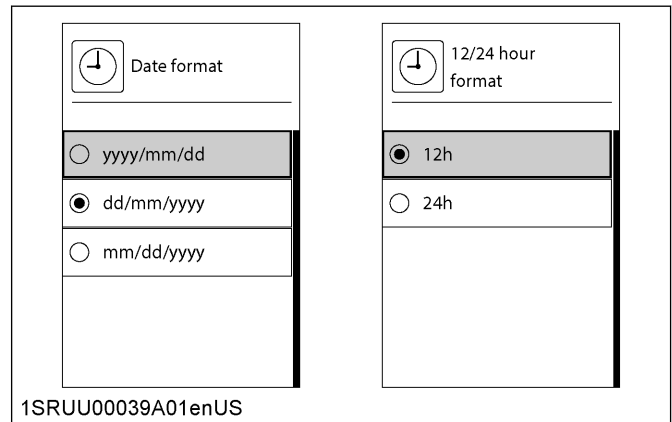

3. Rotate the jog dial to the right or to the left to move the cursor. Select the desired format.
4. Press the jog dial to save the new settings, or press the return switch to retain the previous settings.

2.14.3 Setting the display brightness

The display brightness can be set to one of 10 levels. It is possible to register separate brightness settings for when the working light is on and when the working light is off.

1. Press the menu switch to make the menu bar appear on the display.

2. Rotate the jog dial to the right to select “Various settings”, and press the jog dial.

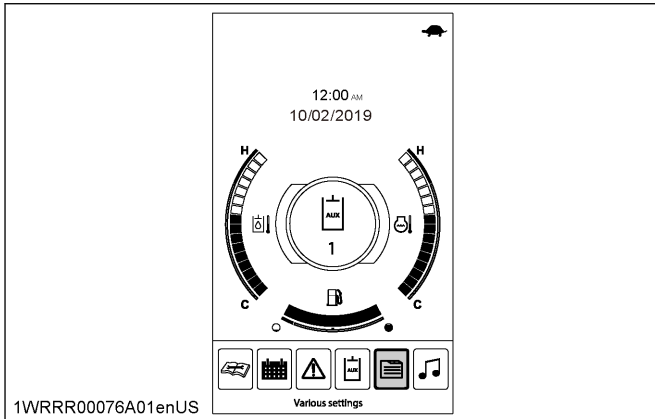

3. Rotate the jog dial to the right to select “Display brightness”, and press the jog dial.

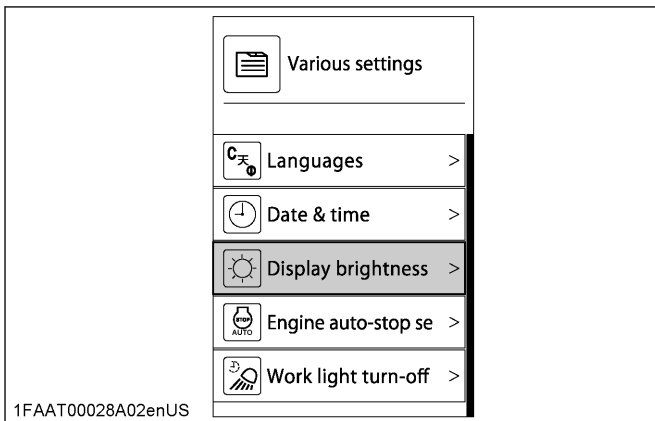

4. Rotate the jog dial to the right or left to select “Day” or “Night”, and press the jog dial.

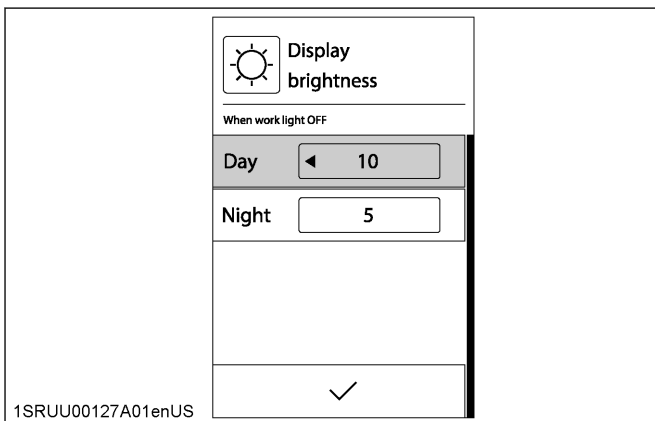

NOTE :

- “Day” is the brightness setting for when the working light is off, and “Night” is the brightness setting for when the working light is on.

Default settings	
Day	10
Night	5

5. Rotate the jog dial to the right or left to increase or decrease the numerical value, and press the jog dial to confirm the selection.
6. Rotate the jog dial to the right to select “✓” and press the jog dial to save the new settings, or press the return switch to retain the previous settings.

2.14.4 Setting the engine auto-stop function

It is possible to set the amount of idling time that passes before the engine auto-stop function activates.

1. Turn the starter switch to the [RUN] position.
2. Press the menu switch to make the menu bar appear on the display.
3. Rotate the jog dial to the right to select “Various settings”, and press the jog dial.
4. Rotate the jog dial to the right to select “Engine auto-stop setting”, and press the jog dial.

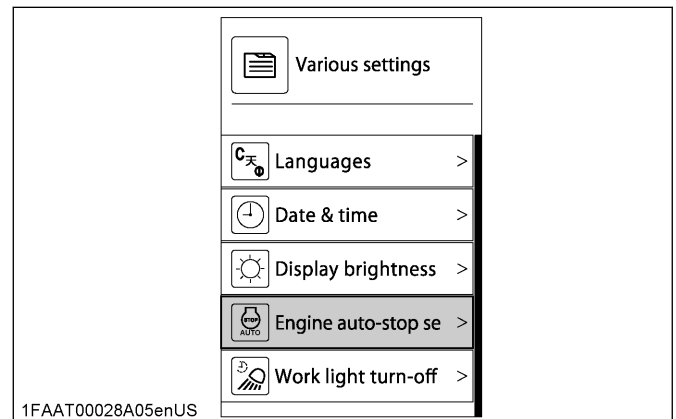

5. Rotate the jog dial to the right or left to select “ON/OFF” or “Time”, and press the jog dial.

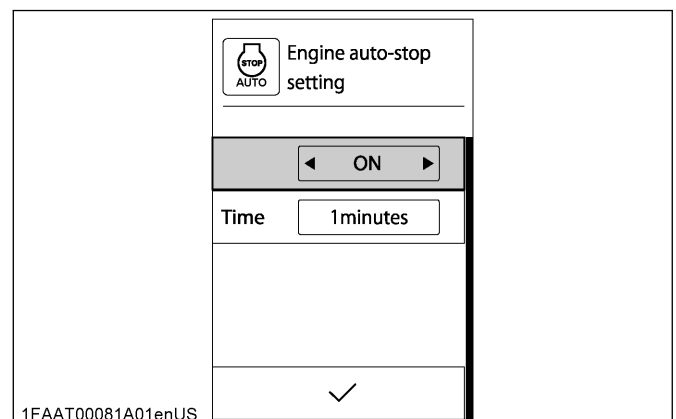

- Rotate the jog dial to the right or left to select the desired setting, and press the jog dial to confirm the selection.

NOTE :

- The engine auto-stop setting must be set to “ON” before the time can be set.
- The time can be set to 1, 3, 5, 10, 15, 20, 25 or 30 minutes.

- Rotate the jog dial to the right to select “✓” and press the jog dial to save the new settings, or press the return switch to retain the previous settings.

2.14.5 Setting the work light turn-off delay function

The working light turn-off can be delayed for a given time after turning off the machine. The working light switch can be used to manually turn off the working light when the turn-off delay function is activated.

- Turn the starter switch to the [RUN] position.
- Press the menu switch to make the menu bar appear on the display.
- Rotate the jog dial to the right to select “Various settings”, and press the jog dial.

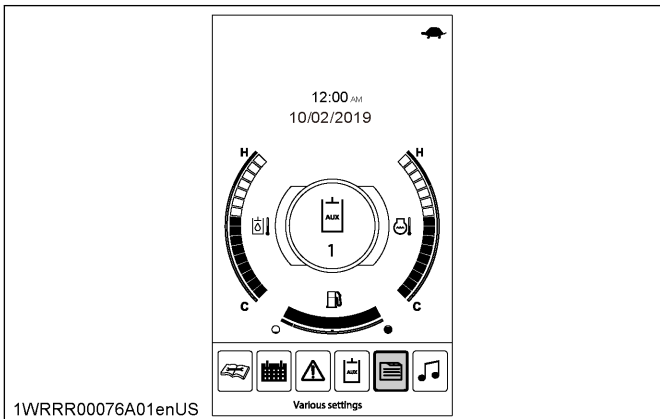

- Rotate the jog dial to the right to select “Working light turn-off delay”, and press the jog dial.

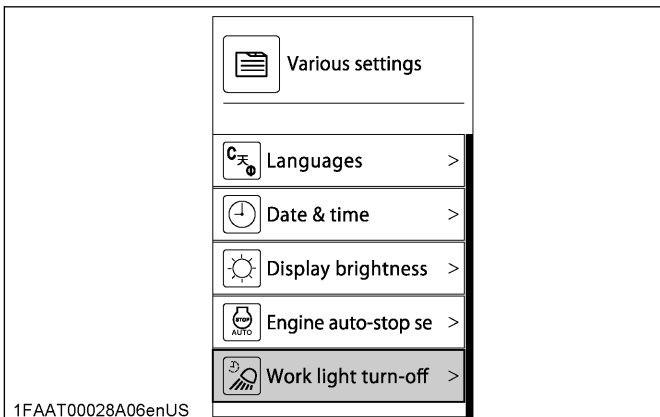

- Rotate the jog dial to the right or left to select “ON/OFF” or “Time”, and press the jog dial.

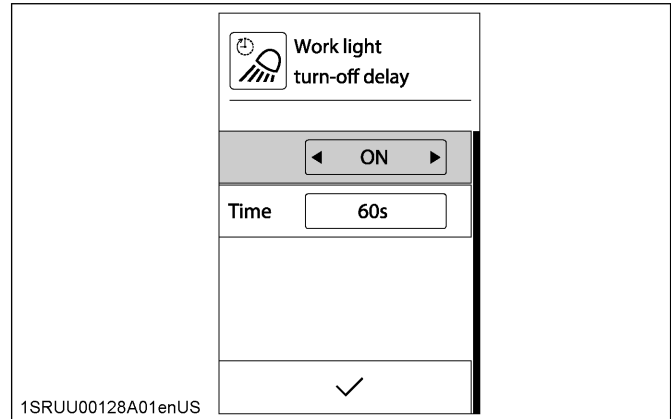

- Rotate the jog dial to the right or left to select the desired setting, and press the jog dial to confirm the selection.

NOTE :

- The work light turn-on delay must be set to “ON” before the delay time can be set.
- The delay time can be set in 30 second increments from 30 to 120 seconds.

- Rotate the jog dial to the right to select “✓” and press the jog dial to save the new settings, or press the return switch to retain the previous settings.

2.14.6 Registering new user passwords

- Turn the starter switch to the [RUN] position.
- Press the menu switch to make the menu bar appear on the display.
- Rotate the jog dial to select “Various settings”, and press the jog dial.
- Rotate the jog dial to select “Password settings”, and press the jog dial.

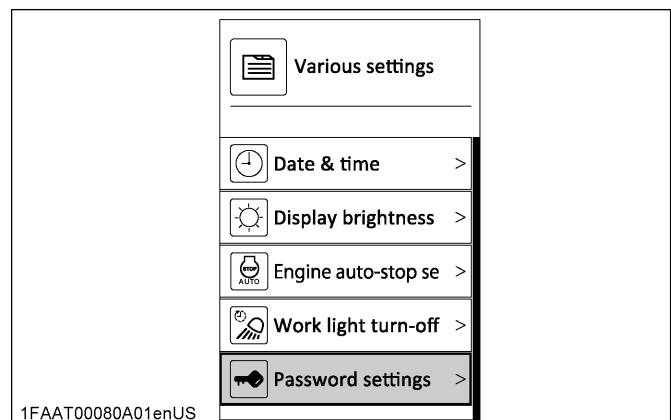

- Enter the machine password.
When the machine password has been verified, the “Password settings” screen appears.

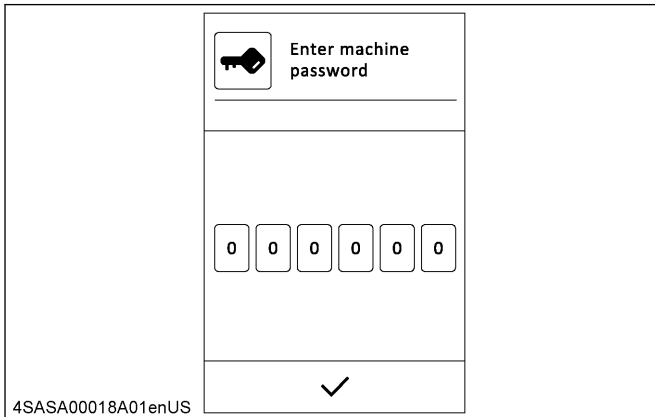

- Rotate the jog dial to select “User password”, and press the jog dial.

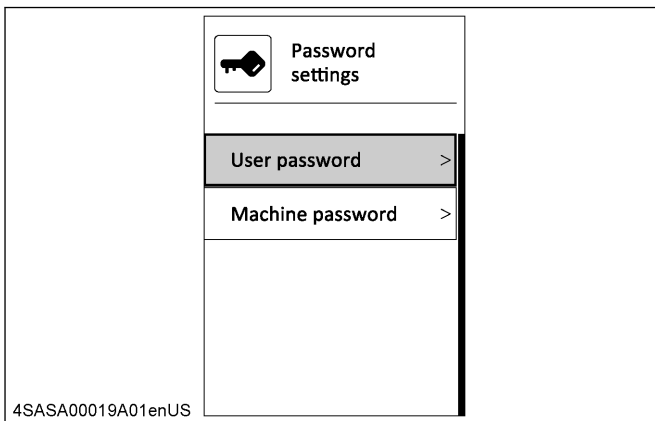

- Rotate the jog dial to select one of the “Unregistered” password numbers, and press the jog dial.

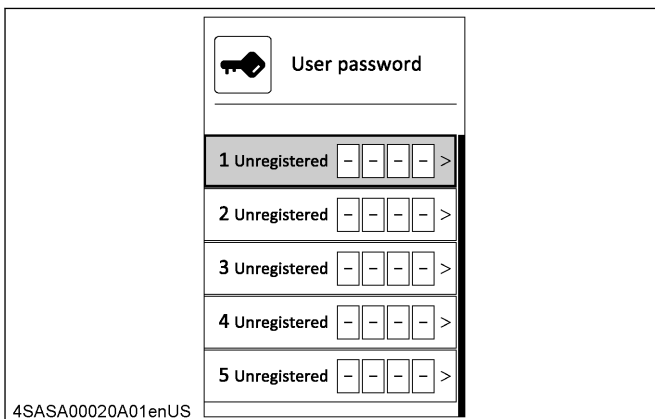

- Enter the new user password of your choice.

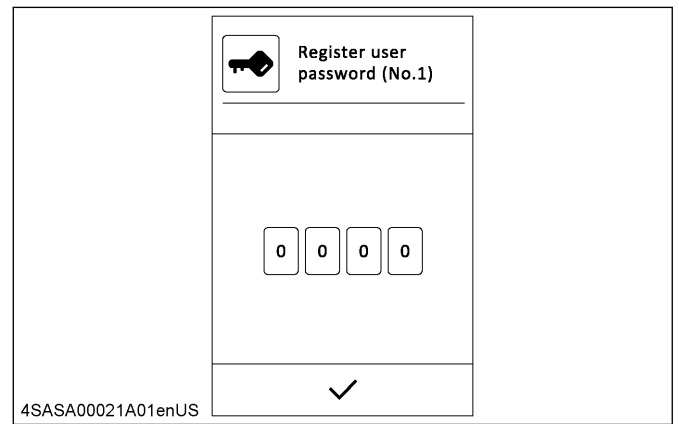

- Rotate the jog dial to select “✓” and press the jog dial to register the new user password.

NOTE :

When the return switch is pressed on the new user password registering screen, the registration is not completed and returns to the previous menu screen.

2.14.7 Changing user passwords

- On the “User password” setting screen, rotate the jog dial to select one of the previous registered password numbers.
(For details on selecting the “User password” setting screen, see Registering new user passwords on page 50.)

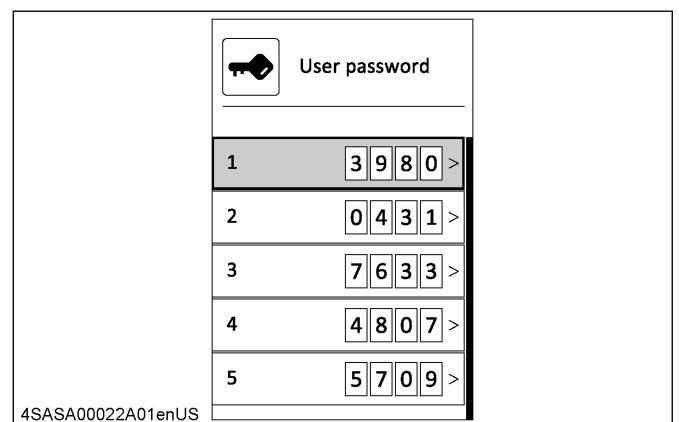
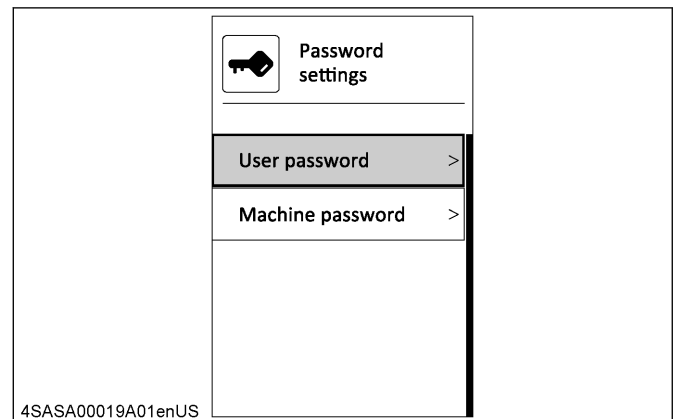

- Press the jog dial, and the following screen appears.

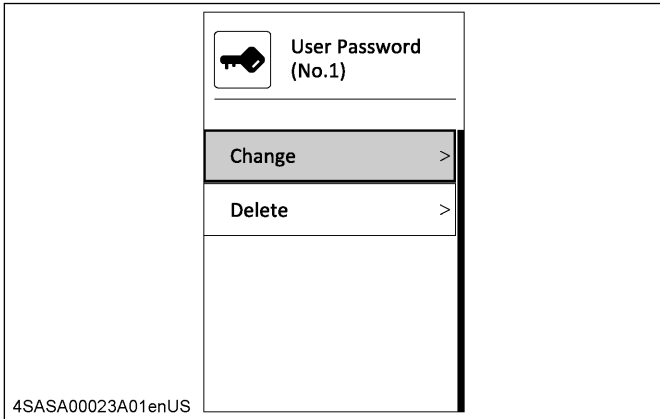

- Rotate the jog dial to select “Change”, and press the jog dial.

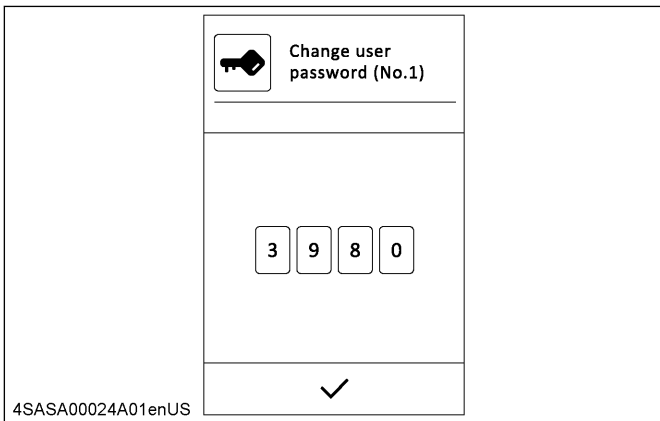

- Enter the new user password of your choice.
- Rotate the jog dial to select “✓” and press the jog dial to change the user password.

NOTE :

When the return switch is pressed on the new user password changing screen, the change is not completed and returns to the previous menu screen.

2.14.8 Deleting user passwords

- On the “User password” setting screen, rotate the jog dial to select one of the previous registered password numbers.
(For details on selecting the “User password” setting screen, see Registering new user passwords on page 50.)

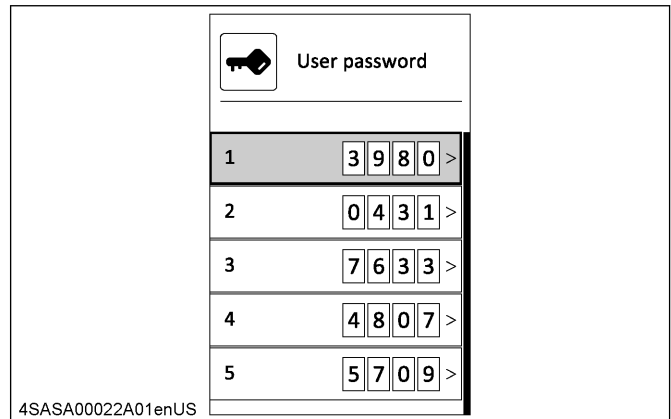
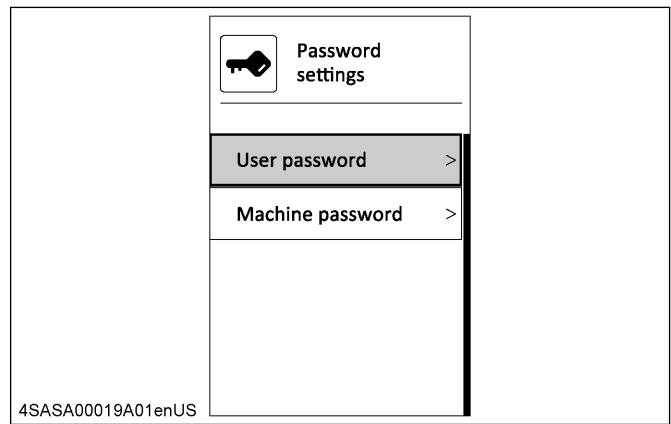

- Press the jog dial, and the following screen appears.

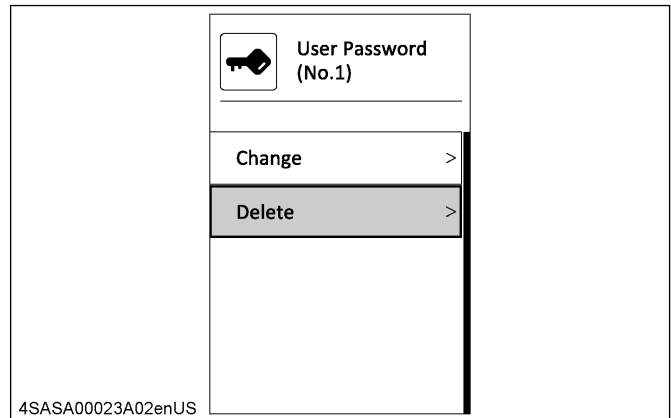

3. Rotate the jog dial to select “Delete”, and press the jog dial.



4. After confirming that the password to be deleted is correct, select “✓” and press the jog dial to complete the deletion.

2.14.9 Changing the machine password

1. On the “Password settings” screen, rotate the jog dial to select “Machine password”.
(For details on selecting the “Password settings” screen, see Registering new user passwords on page 50.)

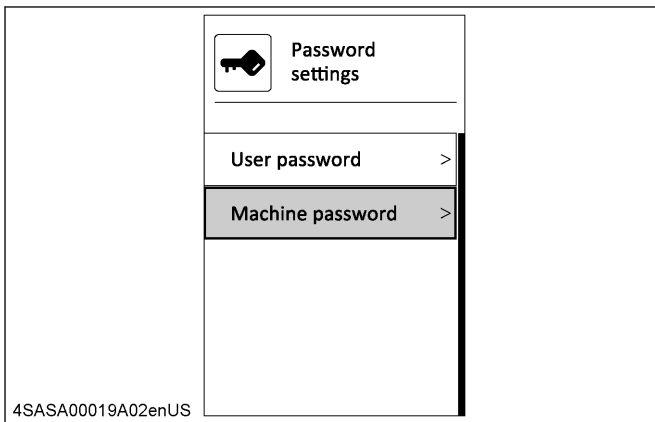

2. Press the jog dial, and the following screen appears.

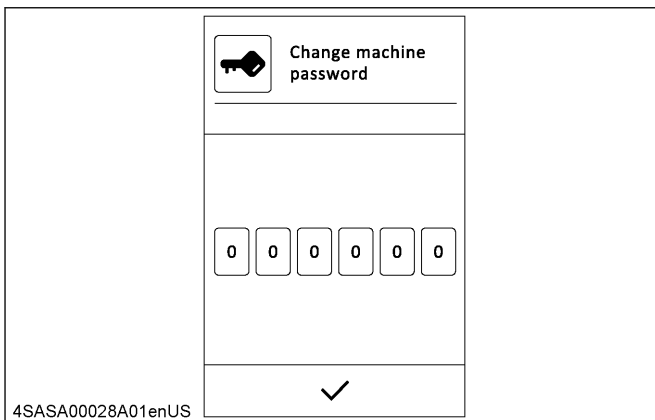

3. Enter the new machine password of your choice.
4. Rotate the jog dial to select “✓”, and press the jog dial.

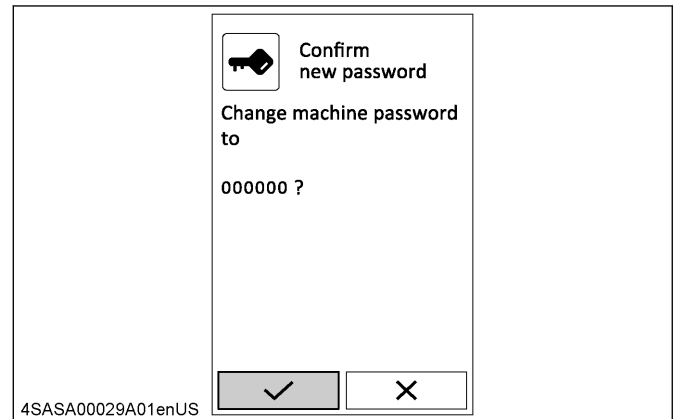

5. After confirming that the new machine password is correct, select “✓” and press the jog dial to confirm change.

NOTE :

In the event of a forgotten machine password, it will no longer be possible to register, change, or delete user passwords. A Kubota dealer must set a new machine password.

2.14.10 Setting the heat-up function

When the coolant temperature is low, this function increases the engine’s idle speed to help warm up the engine faster. It operates when the cooling water temperature is -10°C (14°F) or less when starting the engine.

1. Turn the starter switch to the [RUN] position.
2. Press the menu switch to make the menu bar appear on the display.
3. Rotate the jog dial to the right to select “Various settings”, and press the jog dial.

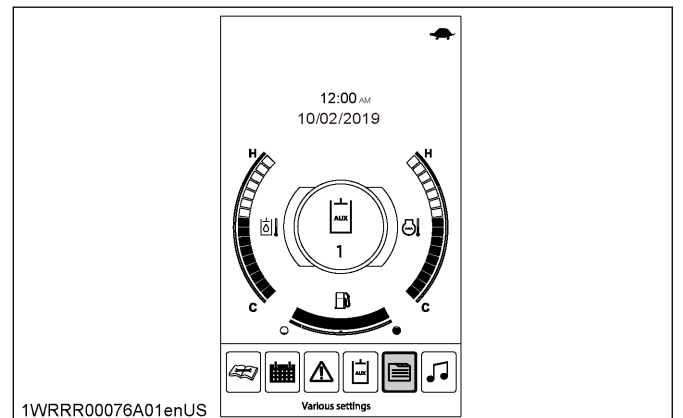

- Rotate the jog dial to the right to select “Heat-up function”, and press the jog dial.

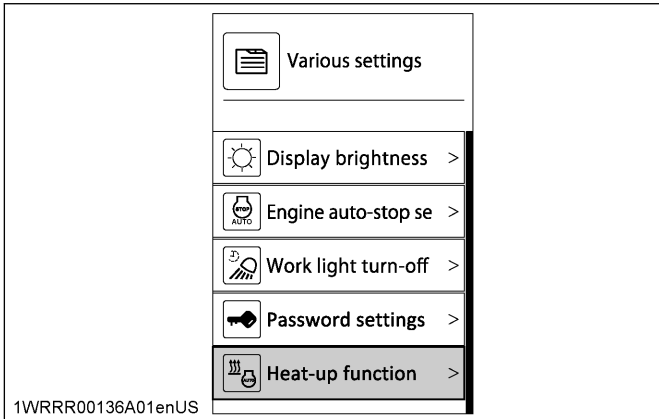

- Rotate the jog dial to the right or left to select “ON/OFF”, and press the jog dial.

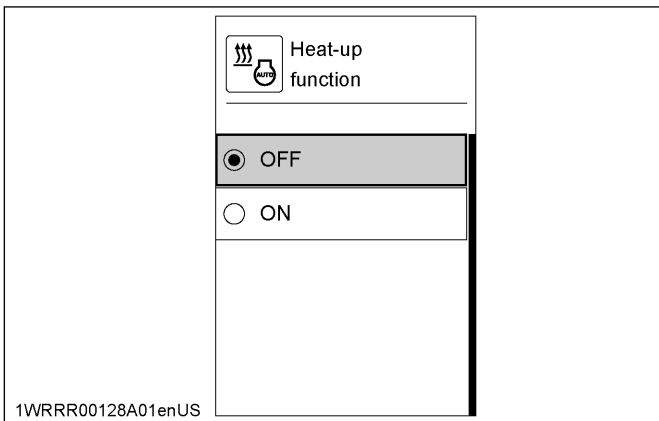

- Rotate the jog dial to the right or left to select the desired setting, and press the jog dial to confirm the selection.
- Rotate the jog dial to the right to select “✓” and press the jog dial to save the new settings, or press the return switch to retain the previous settings.

2.15 Audio mode

2.15.1 Changing the audio screen

You can change to the audio screen with the following operations:

- Operation of menu bar
- Operation of audio pop-up

Changing from the menu bar

- Press the menu switch to make the menu bar appear on the display.

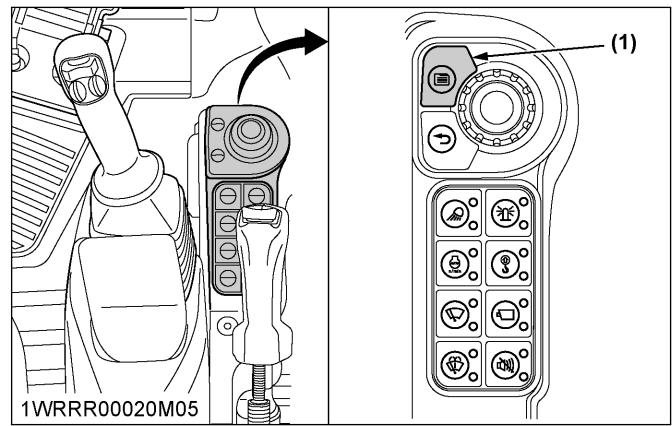

(1) Menu switch

- Rotate the jog dial to select the **[Audio]** icon, and press the jog dial switch to make the audio screen appear on the display.

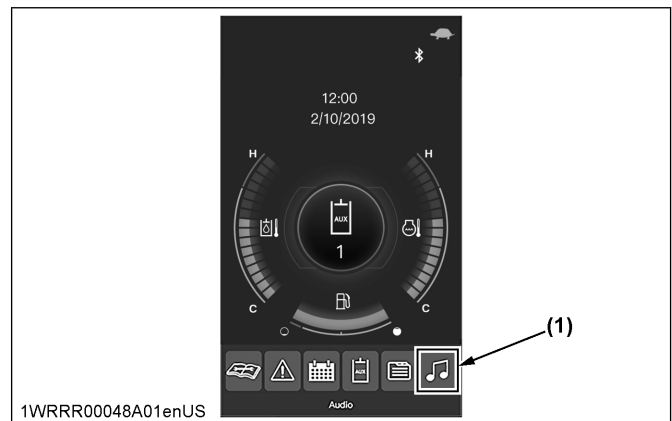

(1) Audio icon

Changing from the audio pop-up

NOTE :

- The audio pop-up appears only when the audio power is on.

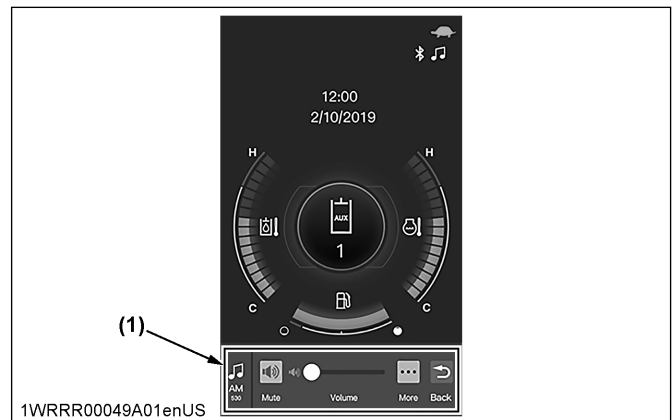

(1) Audio pop-up

- The selected source display area of the audio pop-up shows the currently selected audio source and receiving frequency.

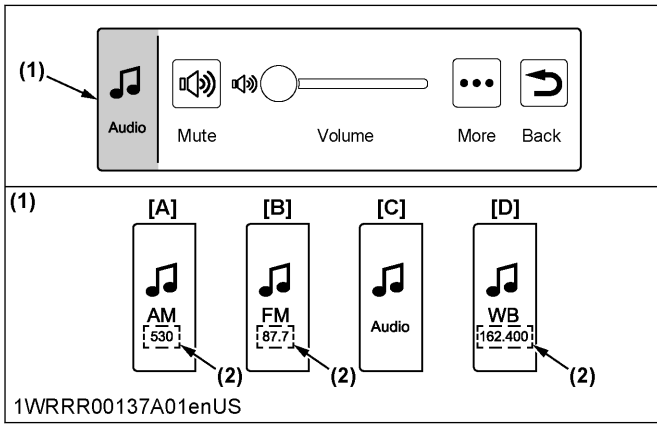

- (1) Selected source display area [A] AM radio selected
 (2) Receiving frequency [B] FM radio selected
 [C] Bluetooth selected
 [D] Weather band selected

1. Rotate the jog dial to select the **[More]** icon, and press the jog dial switch to make the audio screen appear on the display.

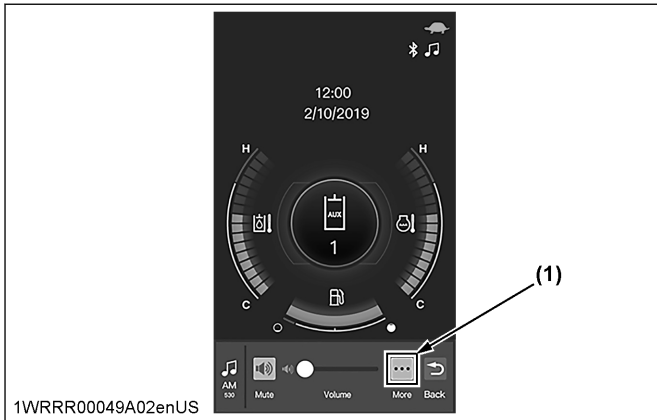

(1) More icon

2.15.2 Switching the audio power ON and OFF

1. Make the audio screen appear on the display.
2. Rotate the jog dial to select the **[Power]** icon and press the jog dial switch to turn the power ON or OFF.

Power off state

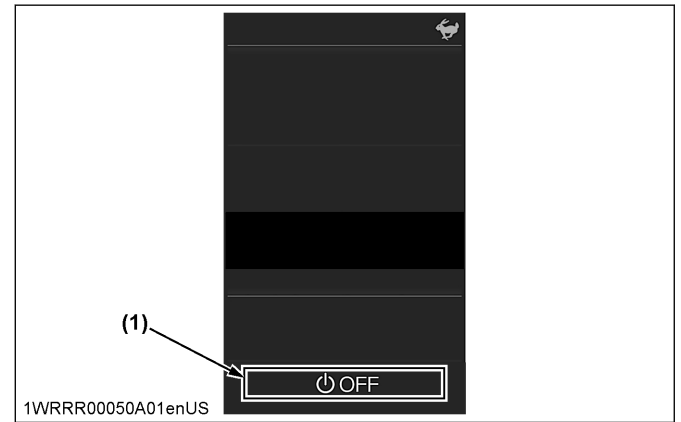

(1) Power icon

Powered on state, AM radio selected

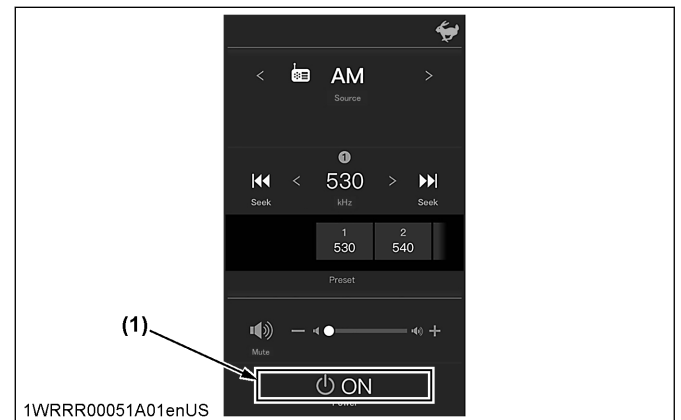

(1) Power icon

Powered on state, FM radio selected

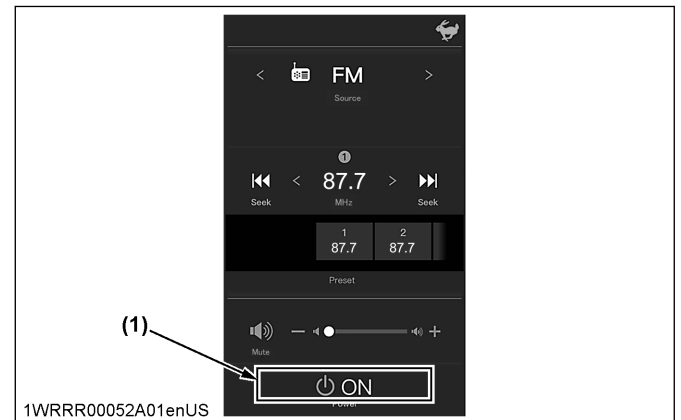

(1) Power icon

Powered on state, Bluetooth device connected

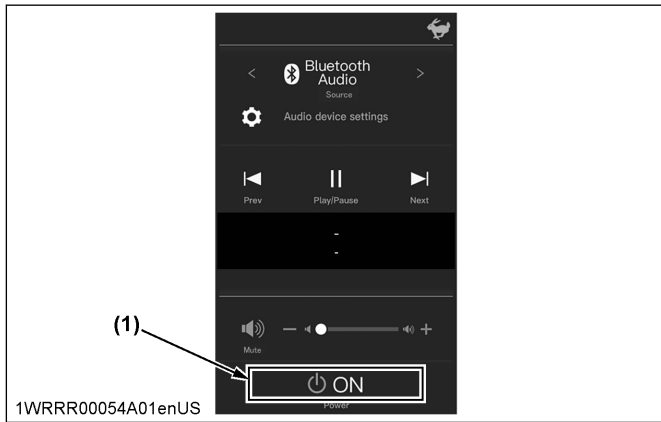

(1) Power icon

Powered on state, Bluetooth device not connected

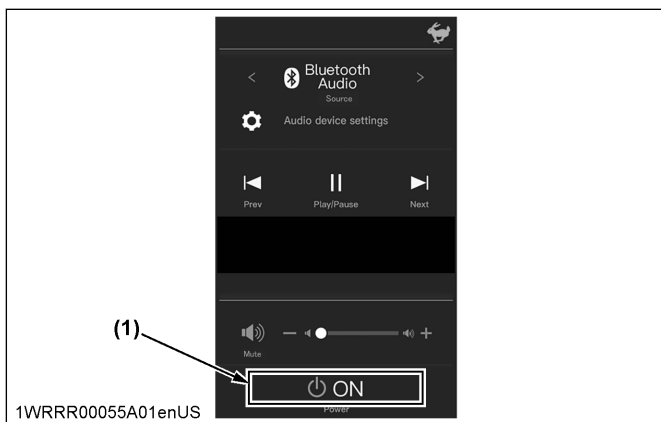

(1) Power icon

Powered on state, weather band selected

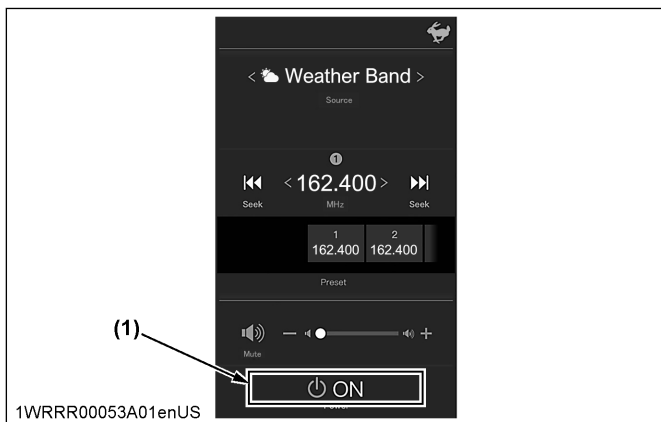

(1) Power icon

2.15.3 Switching audio source

1. Rotate the jog dial on the audio screen to select the audio source area, and press the jog dial switch. The audio source switches every time you press the jog dial switch.

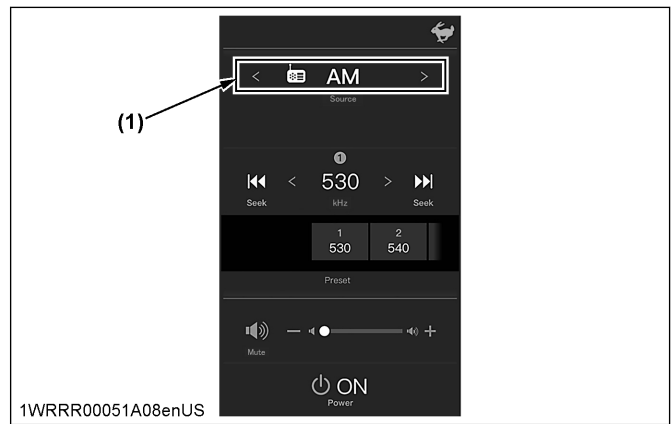

(1) Audio source area

NOTE :

- You can select AM, FM, Bluetooth, or Weather Band

2.15.4 Adjusting the audio volume

NOTE :

- Volume can only be adjusted when the audio is switched on.

Adjusting the volume from the audio screen

1. Rotate the jog dial to select the volume adjustment area, and press the jog dial switch.
2. Rotate the jog dial left or right to adjust to the required volume and press the jog dial switch to confirm the setting.

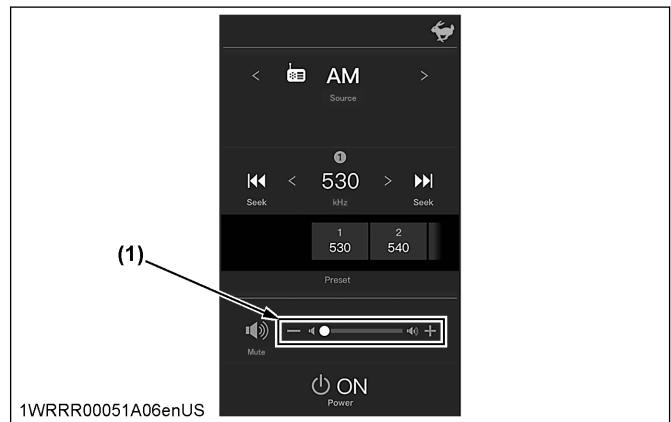

(1) Volume adjustment area

Muting the audio from the audio screen

1. Rotate the jog dial to select the [Mute] icon, and press the jog dial switch.

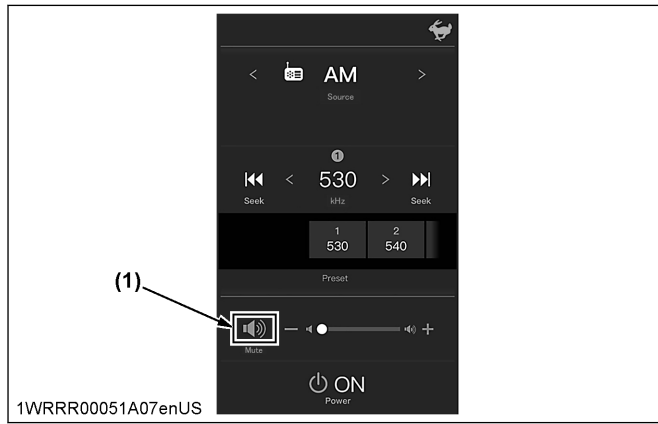

(1) Mute icon

Adjusting the volume from the audio pop-up

1. Rotate the jog dial, select the volume adjustment area, and press the jog dial switch.
2. Rotate the jog dial left or right to adjust to the required volume and press the jog dial switch to confirm the setting.

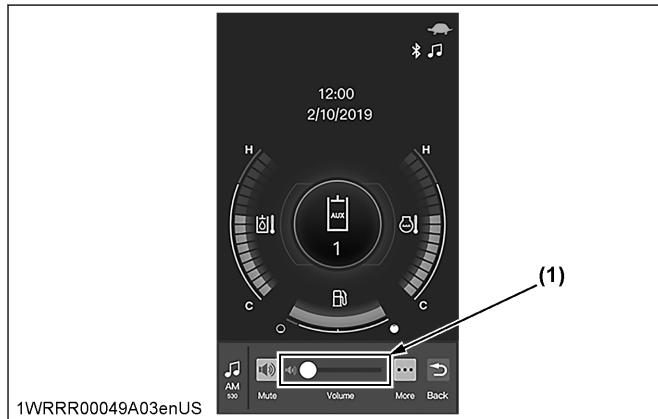

(1) Volume adjustment area

Muting the audio from the audio pop-up

1. Rotate the jog dial to select the [Mute] icon, and press the jog dial switch.

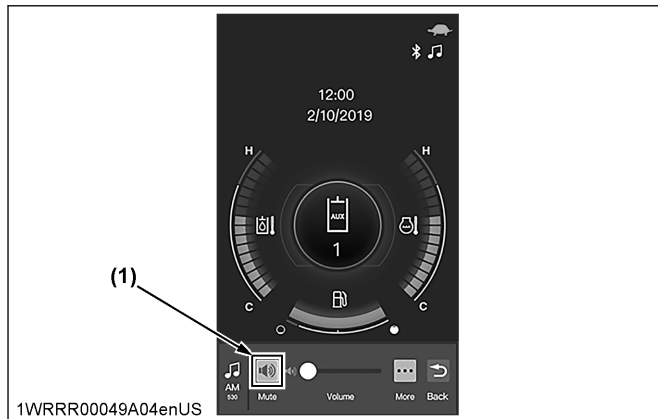

(1) Mute icon

2.15.5 Operating AM mode

Auto seek

1. Rotate the jog dial, select the auto seek down icon or auto seek up icon, press the jog dial switch to search for frequencies that are available for reception.

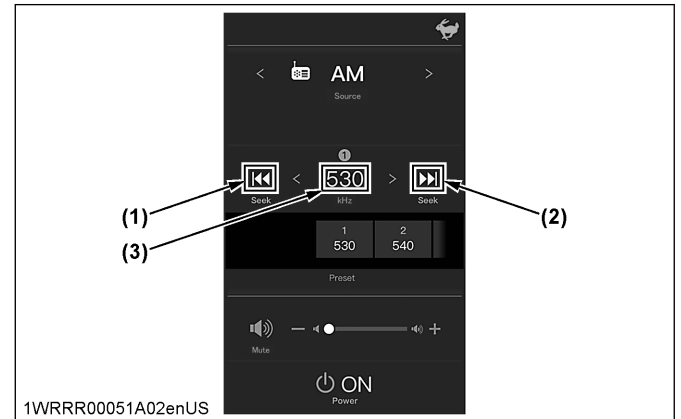

(1) Auto seek down icon
 (2) Auto seek up icon
 (3) Reception frequency

Increasing and decreasing the frequency

1. Rotate the jog dial, select the frequency decrease icon or frequency increase icon, and press the jog dial switch to change the reception frequency.

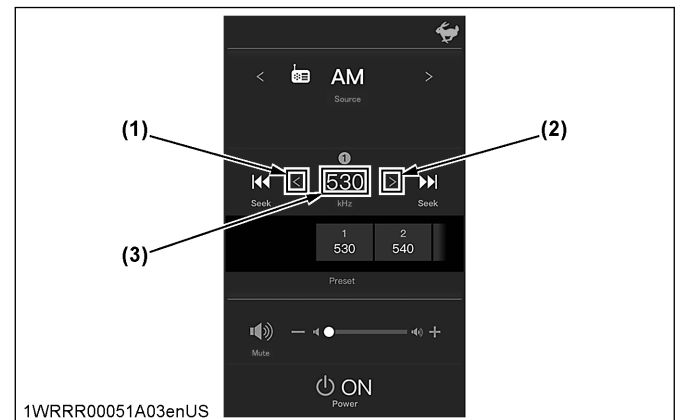

(1) Frequency down icon
 (2) Frequency up icon
 (3) Reception frequency

Changing the channel

1. Rotate the jog dial to select the channel area and press the jog dial switch.
2. Rotate the jog dial to select the required channel, and press the jog dial switch to confirm the selected channel.

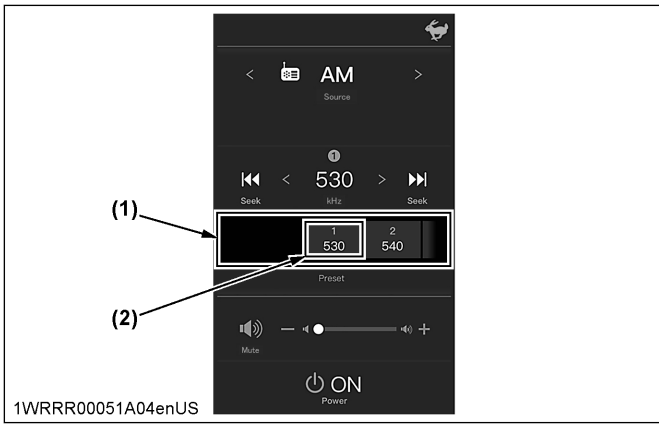

- (1) Channel area
- (2) Channel

Registering frequencies

1. Change the reception frequency to the frequency you want to register.

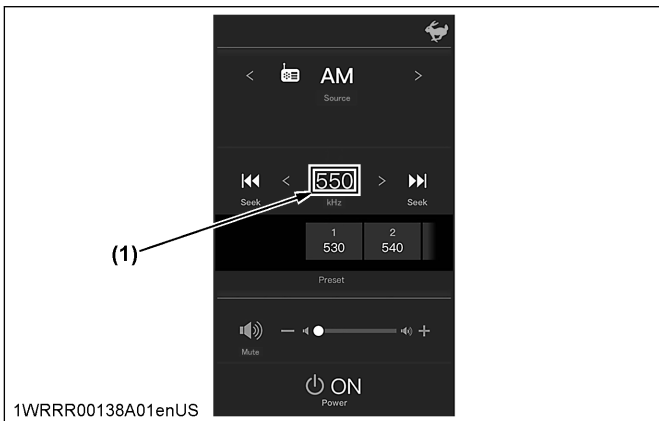

- (1) Reception frequency

2. Rotate the jog dial to select the channel area and press the jog dial switch.
3. Rotate the jog dial to select the channel you want to register, and press and hold the jog dial switch.

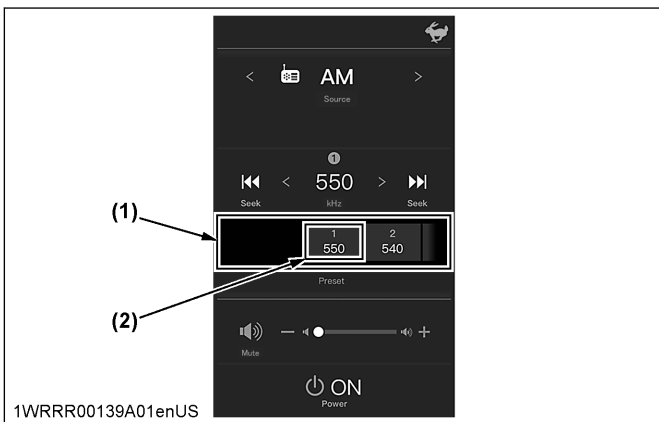

- (1) Channel area
- (2) Channel

2.15.6 Operating FM mode

Auto seek

1. Rotate the jog dial, select the auto seek down icon or auto seek up icon, and press the jog dial switch to search for frequencies that are available for reception.

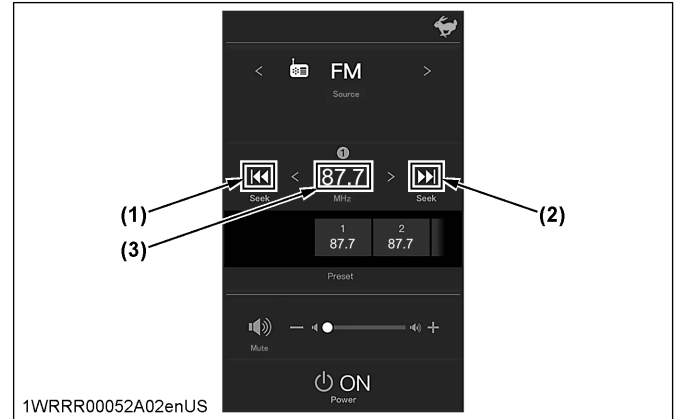

- (1) Auto seek down icon
- (2) Auto seek up icon
- (3) Reception frequency

Increasing and decreasing the frequency

1. Rotate the jog dial, select the frequency decrease icon or frequency increase icon, and press the jog dial switch to change the reception frequency.

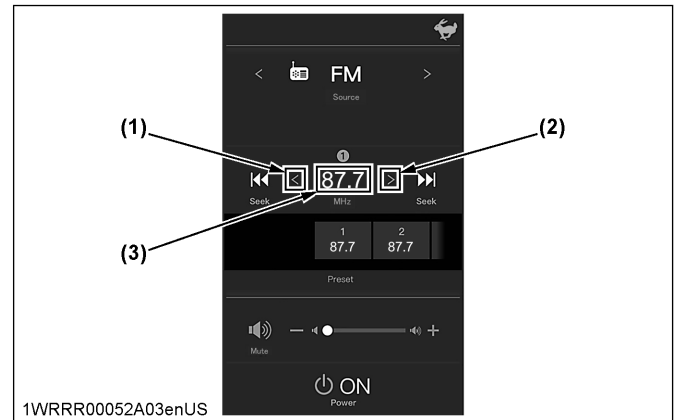

- (1) Frequency down icon
- (2) Frequency up icon
- (3) Reception frequency

Changing the channel

1. Rotate the jog dial to select the channel area and press the jog dial switch.
2. Rotate the jog dial, select the required channel, and press the jog dial switch to confirm the selected channel.

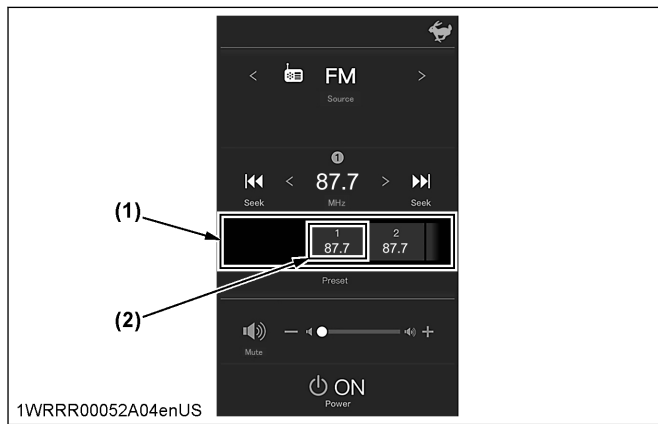

(1) Channel area
(2) Channel

Registering frequencies

1. Change the reception frequency to the frequency you want to register.

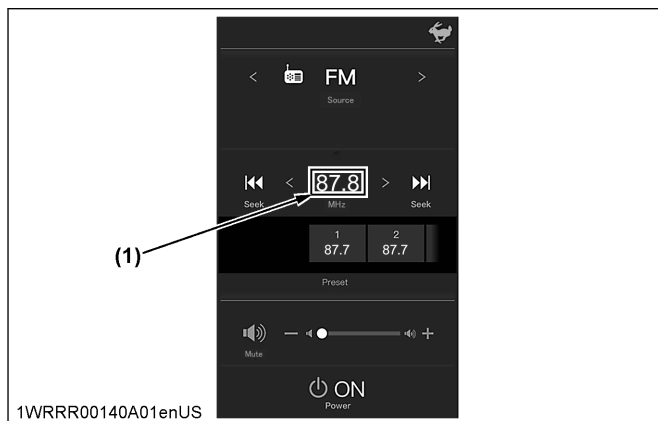

(1) Reception frequency

2. Rotate the jog dial to select the channel area and press the jog dial switch.
3. Rotate the jog dial to select the channel you want to register, and press and hold the jog dial switch.

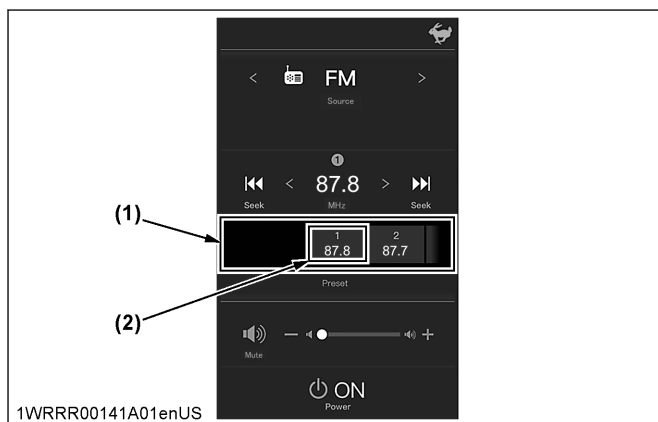

(1) Channel area
(2) Channel

2.15.7 Operating Bluetooth mode

Connecting to a paired Bluetooth device

1. Rotate the jog dial to select the Bluetooth connection setting icon, press the jog dial switch to display the Bluetooth device selection screen.

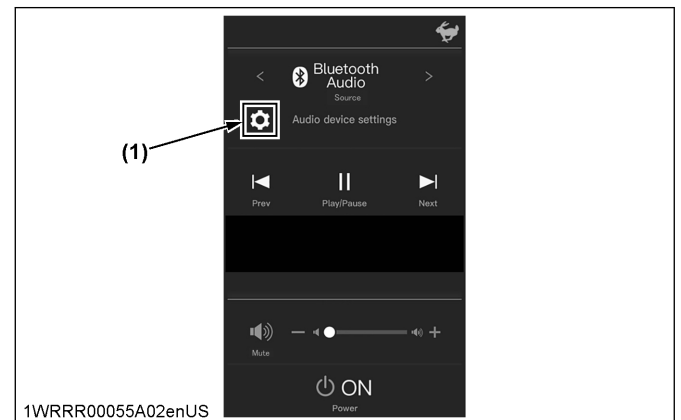

(1) Bluetooth connection setting icon

2. Rotate the jog dial to select the paired Bluetooth device you want to connect and press the jog dial switch to establish the Bluetooth connection.

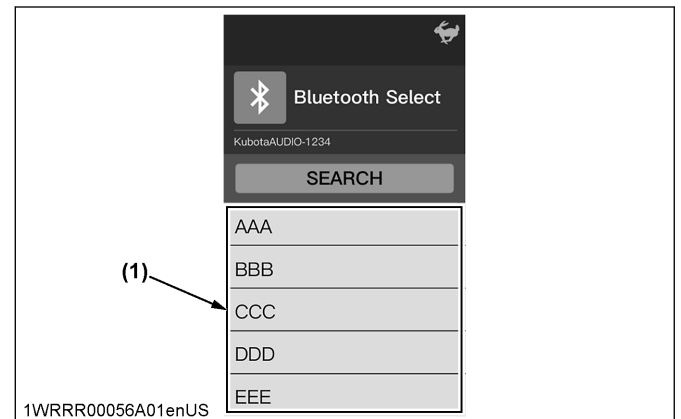

(1) List of paired Bluetooth devices

NOTE :

- If you cannot connect to a Bluetooth device, restart the Bluetooth device and try connecting again.
- Up to 5 paired Bluetooth devices can be registered.

Connecting to an unpaired Bluetooth device

1. Rotate the jog dial to select the Bluetooth connection setting icon, press the jog dial switch to display the Bluetooth device selection screen.

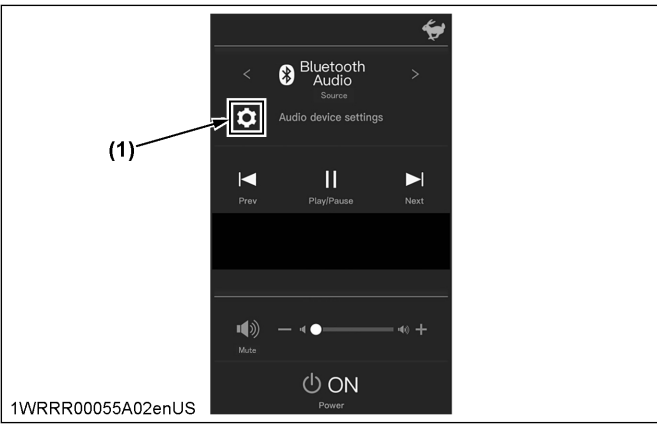

(1) Bluetooth connection setting icon

2. Rotate the jog dial to select the search icon, press the jog dial switch to search the Bluetooth device.

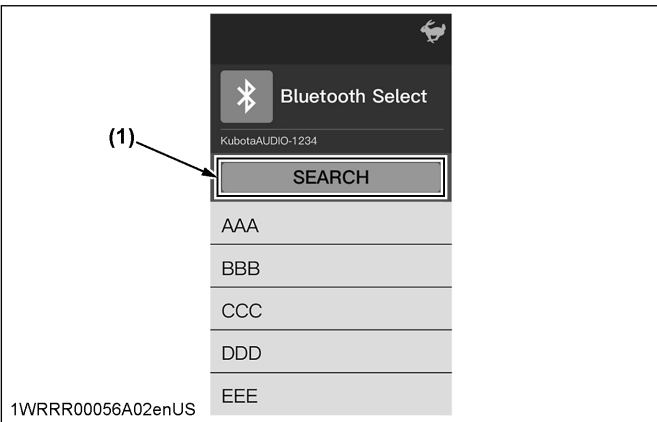

(1) Search icon

3. Rotate the jog dial and select the Bluetooth device that you want to connect from the list of detected Bluetooth devices, and press the jog dial switch.

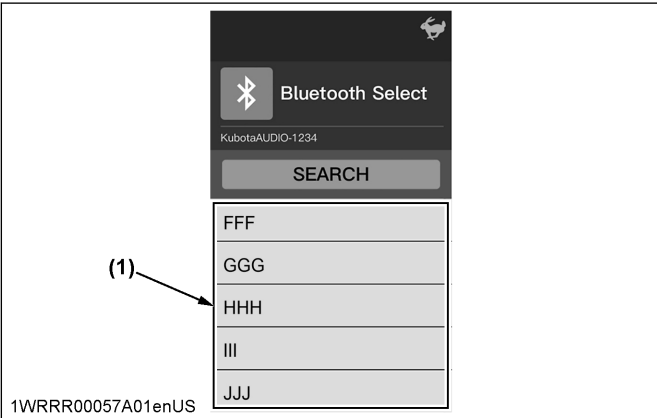

(1) List of detected Bluetooth devices

NOTE :

- If you cannot connect to a Bluetooth device, restart the Bluetooth device and try connecting again.
- The Bluetooth devices that can be connected are smartphones or audio players.

- Up to 5 paired Bluetooth devices can be registered.
- After the machine is turned on and the home screen is displayed on the instrument panel, you can make a Bluetooth connection.

Playing and stopping music

1. Rotate the jog dial to select the Play/Pause icon, and press the jog dial to toggle between music play and stop.

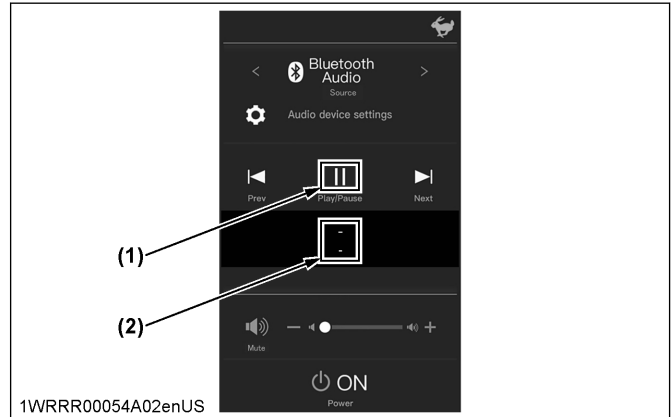

(1) Play/Pause icon
(2) Singer name and song title

Selecting next or previous track

1. Rotate the jog dial to select the Next icon or Previous icon and press the jog dial switch to change the music to be played.

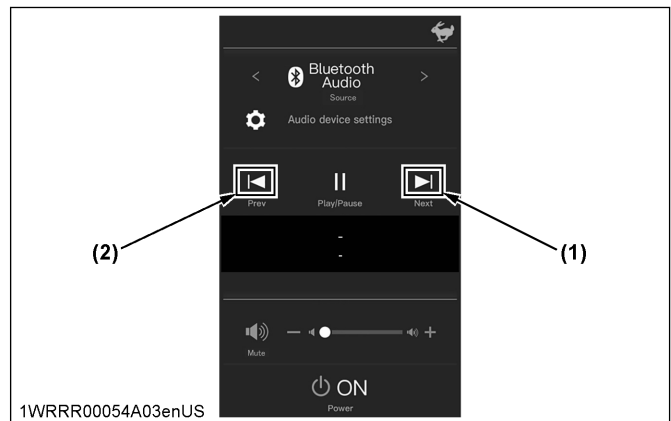

(1) Next icon
(2) Previous icon

2.15.8 Operating weather band mode

Auto seek

1. Rotate the jog dial, select the auto seek down icon or auto seek up icon, press the jog dial switch to search for frequencies that are available for reception.

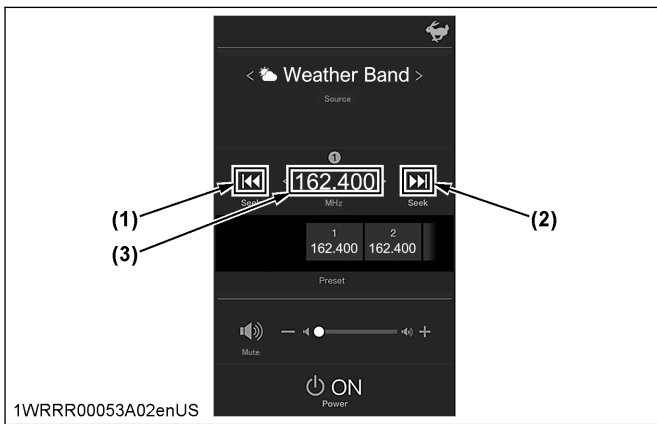

- (1) Auto seek down icon
- (2) Auto seek up icon
- (3) Reception frequency

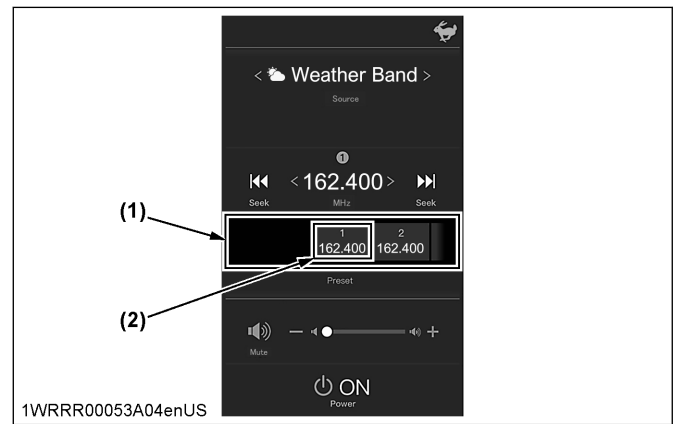

- (1) Channel area
- (2) Channel

Increasing and decreasing the frequency

1. Rotate the jog dial, select the frequency decrease icon or frequency increase icon, and press the jog dial switch to change the reception frequency.

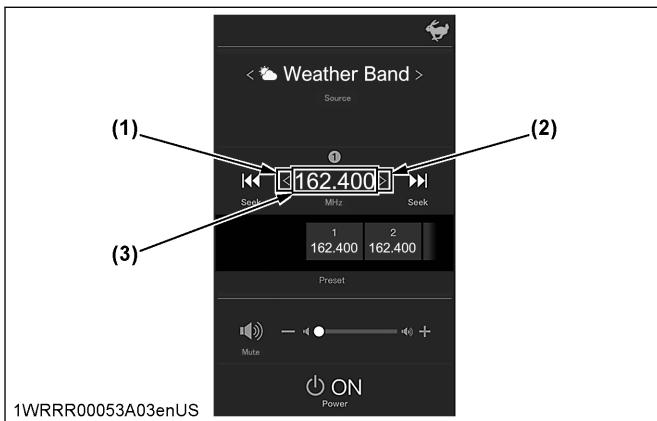

- (1) Frequency up icon
- (2) Frequency down icon
- (3) Reception frequency

Registering frequencies

1. Change the reception frequency to the frequency you want to register.

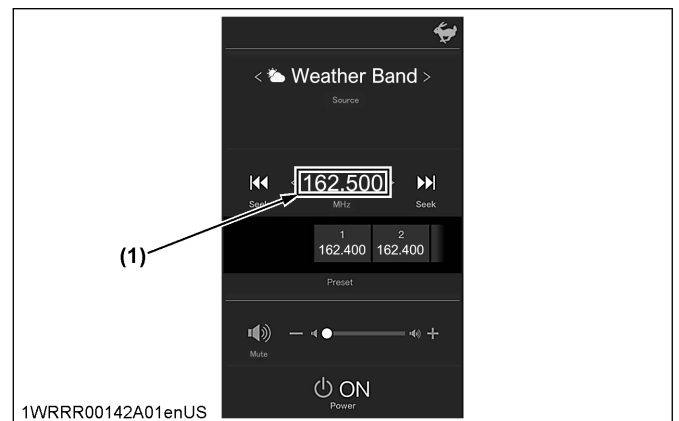

- (1) Reception frequency

2. Rotate the jog dial to select the channel area and press the jog dial switch.
3. Rotate the jog dial select the channel that you want to register and press and hold the jog dial switch.

Changing the channel

1. Rotate the jog dial to select the channel area and press the jog dial switch.
2. Rotate the jog dial to select the required channel and press the jog dial switch to confirm the selected channel.

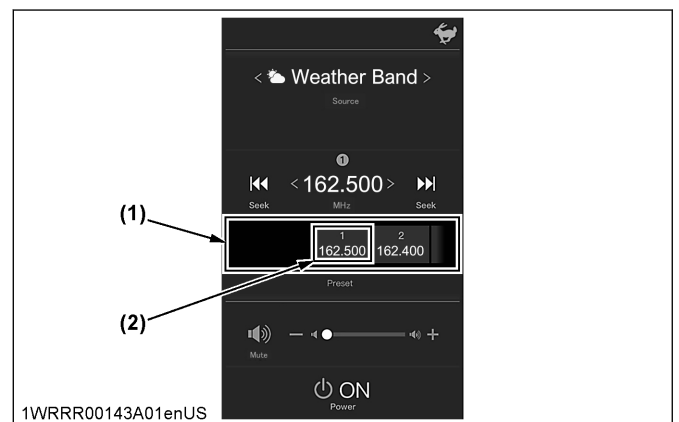

- (1) Channel area
- (2) Channel

2.15.9 Call control for Bluetooth-connected cell phone

When the Bluetooth connected cell phone receives a call, an incoming call pop-up is displayed.

While talking on a Bluetooth connected cell phone, a Talking pop-up appears on the display.

While making a call on a Bluetooth connected cell phone, an outgoing call popup will appear on the display.

Incoming calls

1. While the **[Incoming call]** pop-up is displayed, rotate the jog dial to select the **[Answer]** icon, and press the jog dial switch to connect the call. Rotate the jog dial to select the **[Decline]** icon, and press the jog dial switch to decline the call.

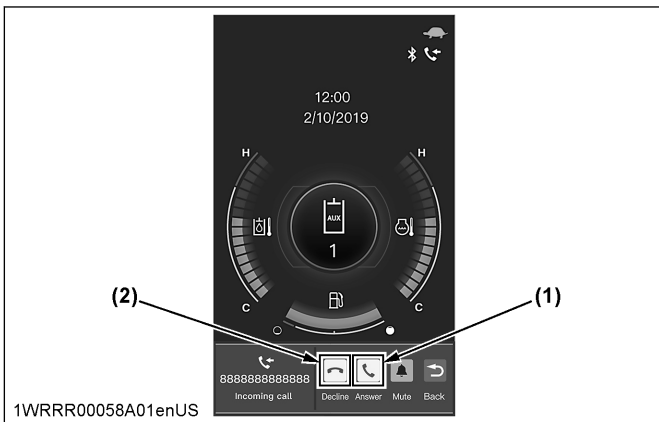

- (1) Answer icon
- (2) Decline icon

Muting the ringtone

1. While the **[Incoming call]** pop-up is displayed, rotate the jog dial to select the **[Mute]** icon, and press the jog dial switch to mute the ringtone.

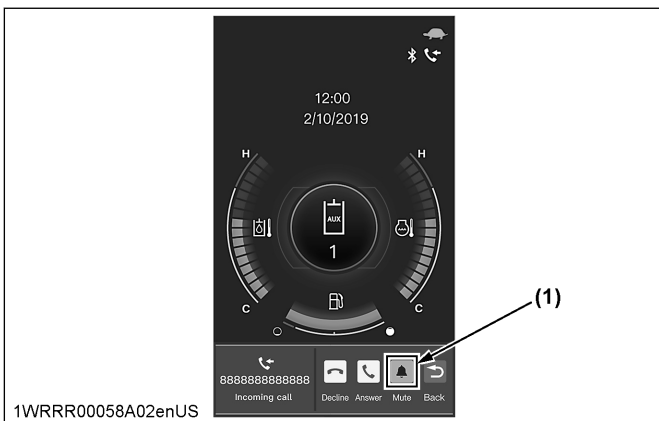

- (1) Mute icon

Ending a call

1. While the **[Talking]** pop-up is displayed, rotate the jog dial to select the **[End]** icon, and press the jog dial switch to end the call.

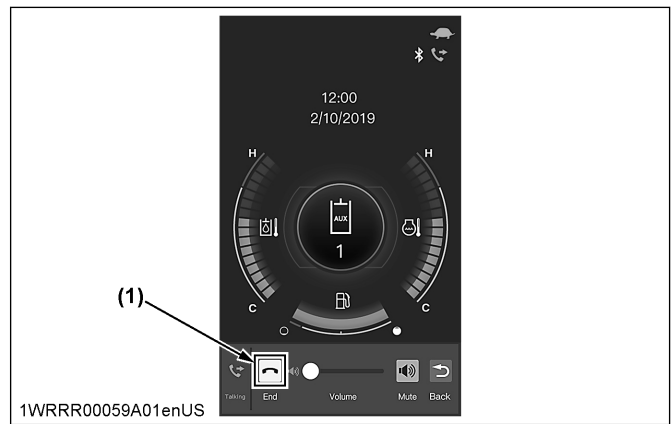

- (1) End icon

Adjusting the call volume

1. While the **[Talking]** pop-up is displayed, rotate the jog dial to select the volume adjustment area, and press the jog dial switch.
2. Rotate the jog dial left or right to adjust the speaker audio volume, and press the jog dial switch to confirm the setting.

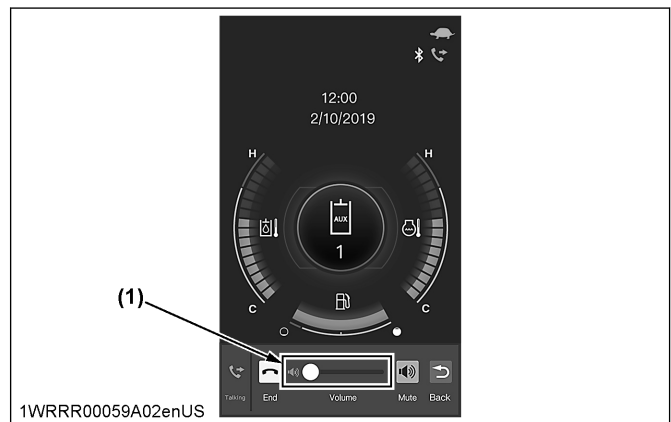

- (1) Volume adjustment area

Muting a call

1. While the **[Talking]** pop-up is displayed, rotate the jog dial to select the **[Mute]** icon, and press the jog dial switch to mute the speaker audio.

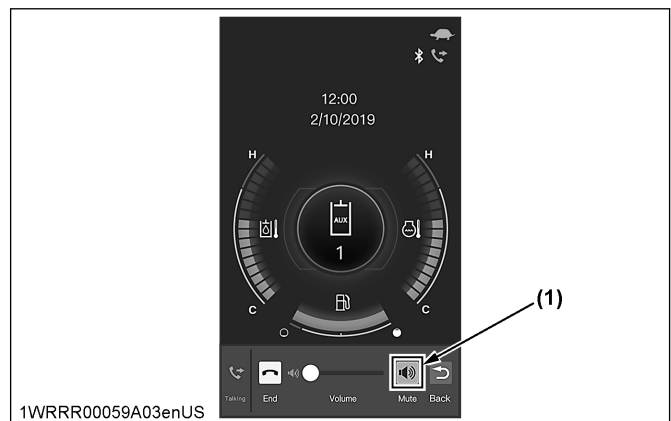

- (1) Mute icon

3. Warning lamp

The warning lamp is used to indicate broken wire, short circuit, fuel shortage, and other problems. The warning lamp starts flashing in red if any problem occurs. If the system senses a warning signal, the warning lamp starts flashing in yellow.

IMPORTANT :

- If the warning lamp illuminates, perform the appropriate inspection and correction accordingly. (See MAINTENANCE on page 110.)

NOTE :

- If any warnings and problems are displayed, an alarm buzzer will beep. (See NAVIGATION SCREENS on page 180.)
- Contact your local Kubota dealer for details concerning care and maintenance.

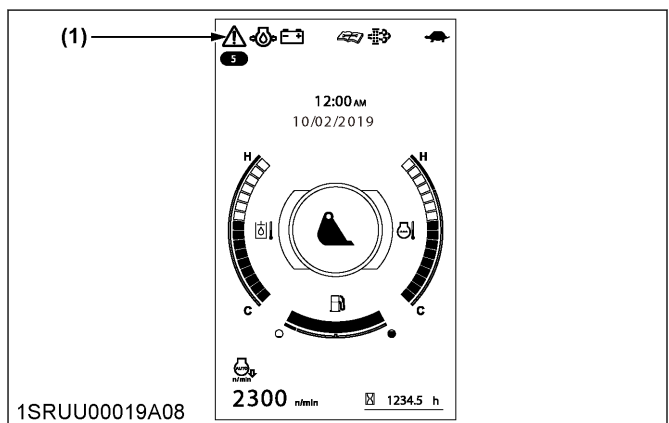

(1) Warning lamp (red, yellow)

4. Display for warnings

4.1 Remaining fuel warning

When the fuel level is very low, the  lamp (yellow) starts flashing and the following message appears on the display.

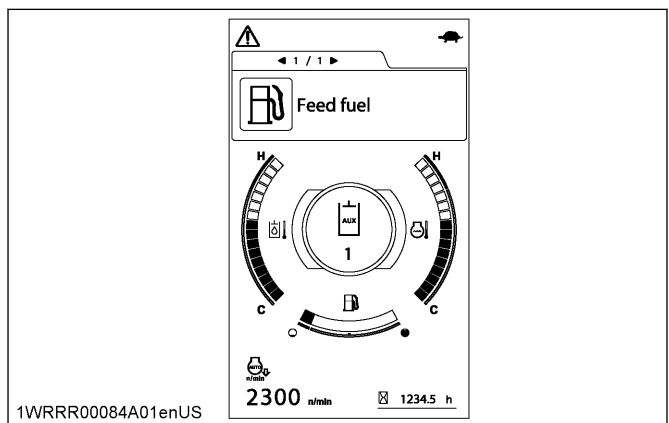

1WRRR00084A01enUS

NOTE :

- After a short period of time, the message shows up again.

4.2 Battery charge warning

If the starter switch is turned to the [RUN] position without starting the engine, and the charging lamp stays off, the charging system has failed. In such a case, immediately contact your local Kubota dealer for repairs.

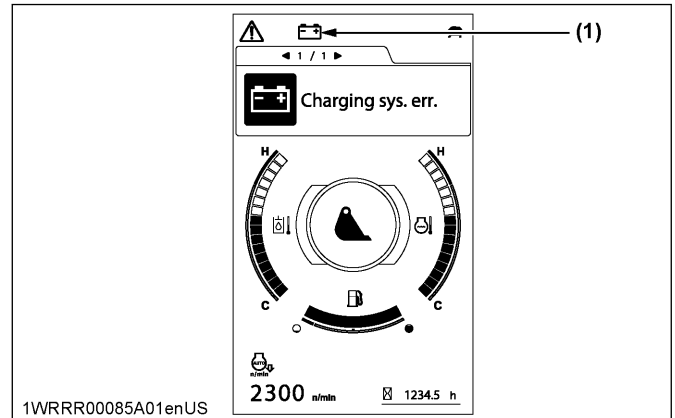

(1) Charging lamp

4.3 Low engine oil pressure warning

When the engine oil pressure drops too low, the  lamp starts flashing red and the following message appears on the display.

Immediately stop the engine and check the engine oil level.

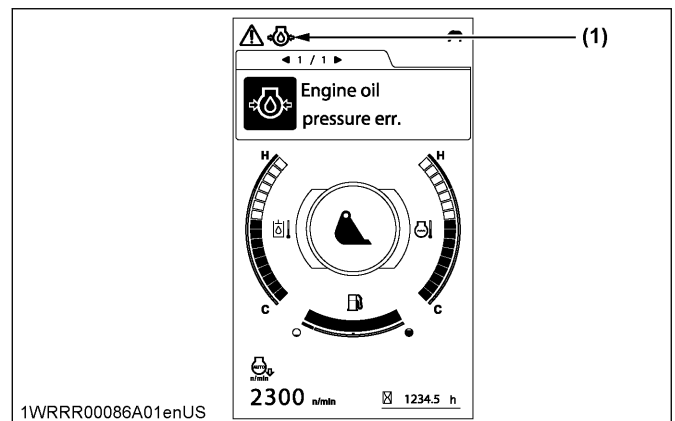

(1) Oil lamp

NOTE :

- If the starter switch is turned to the [RUN] position without running the engine and the oil lamp stays off, then the hydraulic system may have failed. In such a case, immediately contact your local Kubota dealer for repairs.

4.4 Various error warnings

If any components are detected to be experiencing trouble, a message, such as the following one, appears on-screen.
(See NAVIGATION SCREENS on page 180.)

For Example

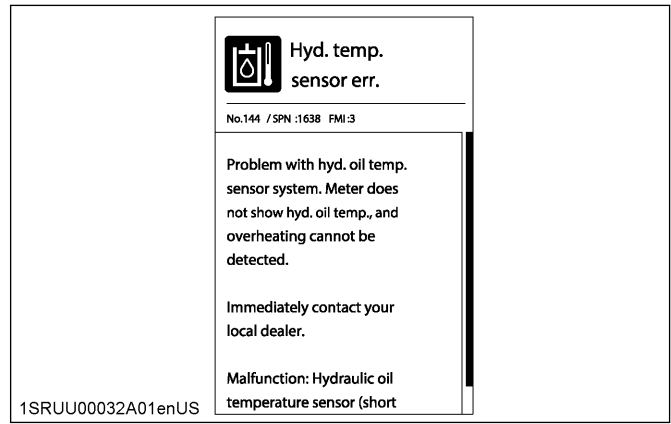
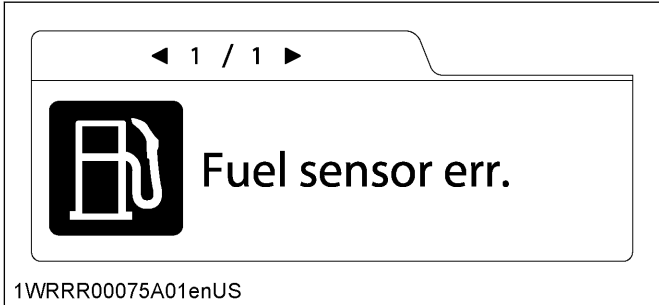

NOTE :

- On this screen, you can use the jog dial to scroll up and down.

4.5 Checking error warnings

1. Press the menu switch to make the menu bar appear on the display.

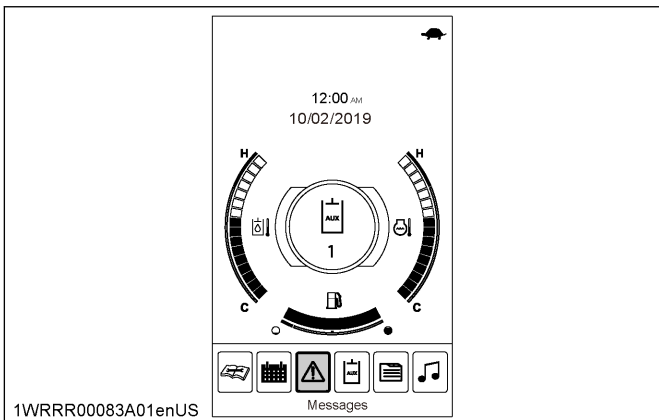

2. Press the jog dial to select "Messages", and the list of error messages appears on the display.

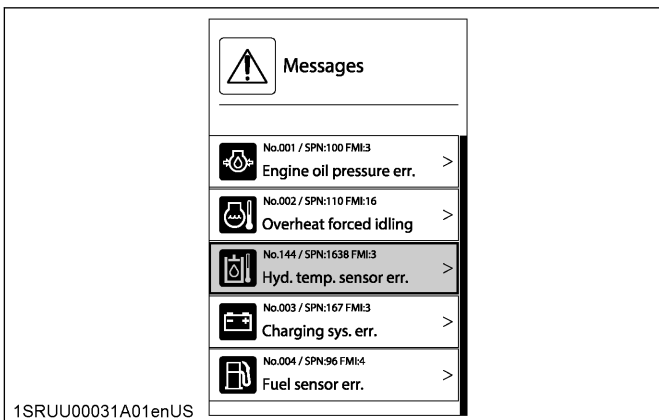

3. Rotate the jog dial to the right to select the desired item, and press the jog dial. A detailed message appears on the display.

HORN SWITCH

Pressing the horn switch sounds the horn. You can use the horn even when the starter switch is in the [STOP] position.

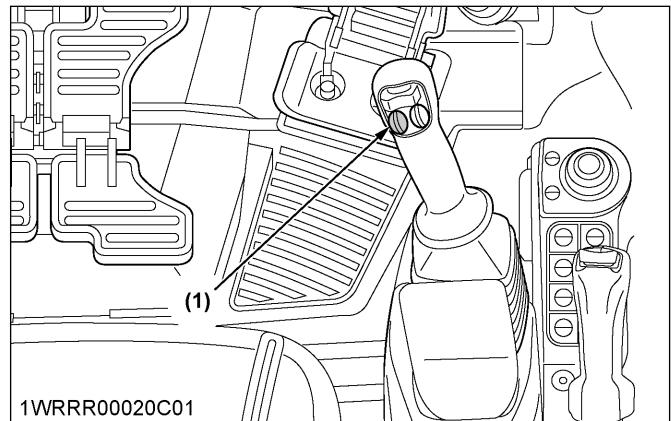

(1) Horn switch

OPERATING THE WORKING LIGHT SWITCH

WARNING

To avoid personal injury or death:

- When working on public roads, be careful not to blind other road users.

1. Turn the starter switch to the [RUN] position.

2. Operate the working light switch as follows:

[Canopy type]

- Press once and the working light turns on. The upper indicator lights up.
- Press again and the working light turns off. The upper indicator goes out.

[CAB type]

- Press once and the working light turns on. The upper indicator lights up.
- Press a second time and the CAB light turns on. Both the upper indicator and the lower indicator light up.
- Press a third time and both the working light and the CAB light turn off. Both the upper indicator and the lower indicator go out.

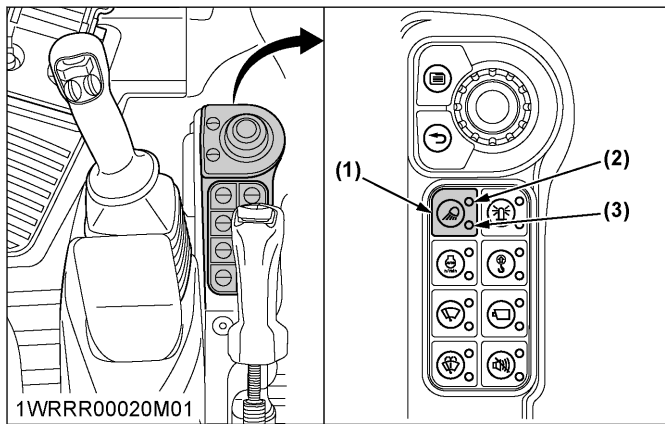

- 1WRRR00020M01
- (1) Working light switch
(2) Upper indicator
(3) Lower indicator

1. Night operation

⚠ WARNING

To avoid personal injury or death:

- When the working light and CAB light alone do not provide sufficient visibility, prepare additional stationary artificial lighting and observe the safety rules for night work.

AUX PORT ENABLE SWITCH

It is possible to freely readjust the actuator's maximum flow rate in the AUX operating mode.
(See AUXILIARY PORT OPERATION on page 92.)

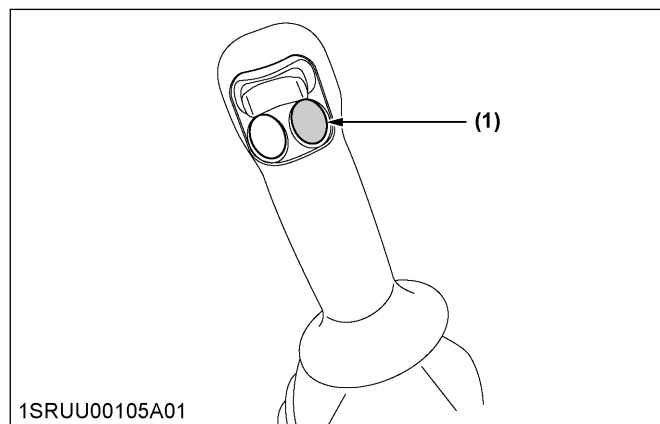

1SRUU00105A01

(1) AUX port enable switch

AUTO IDLE CONTROL SWITCH

The switch is used to enable and disable the Auto Idle control.

Enable

- Press the Auto Idle control switch. When the Auto Idle control is on, the Auto Idle lamp stays on.

Disable

- Press the Auto Idle control switch once again. Now the Auto Idle control is deactivated and the Auto Idle lamp goes out.

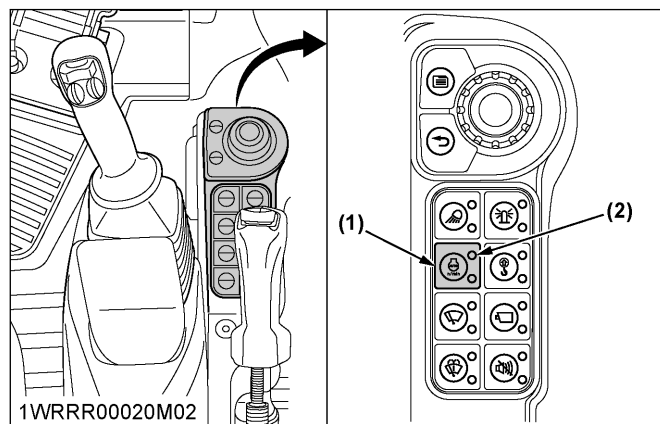

1WRRR00020M02

- (1) Auto Idle control switch
(2) Auto Idle lamp

When Auto Idle control is enabled the Auto Idle indicator appears on the display.

When the engine speed has dropped to idle speed due to Auto Idle control, the Auto Idle indicator flashes.

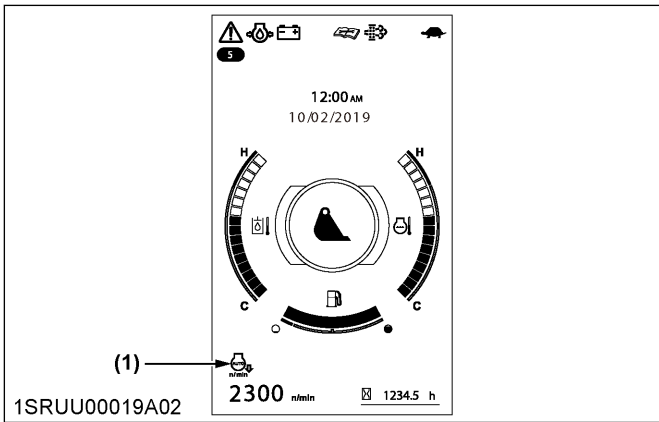

(1) Auto Idle indicator

THROTTLE POTENTIOMETER

- Sit down on the operator's seat and turn the throttle potentiometer clockwise toward high speed, and the engine revs up.
- To stop the engine, turn the throttle potentiometer fully toward low speed and keep the engine at idling speed. Then turn the starter switch to the [STOP] position.

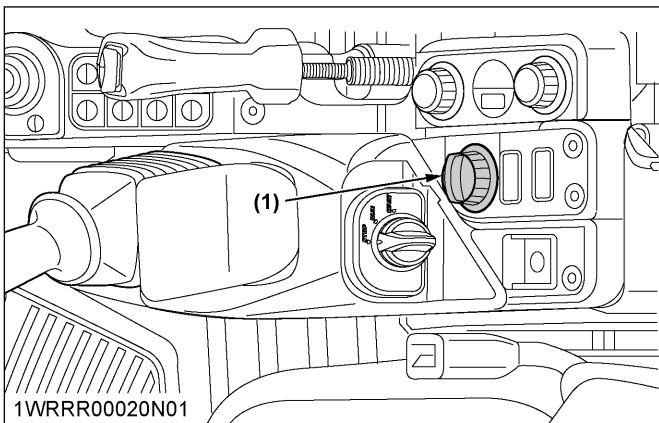

(1) Throttle potentiometer

TRAVEL SPEED SWITCH

Travel speed will increase when this switch is pushed down.

Switching the dual travel speed:

- Press the travel speed switch. The buzzer beeps twice and the travel speed changes from low to high. The speed indicator light changes from the symbol to the symbol.
- Press the travel speed switch again, the buzzer beeps once and the travel speed changes from high speed to low. The speed indicator light changes from the symbol back to the symbol.

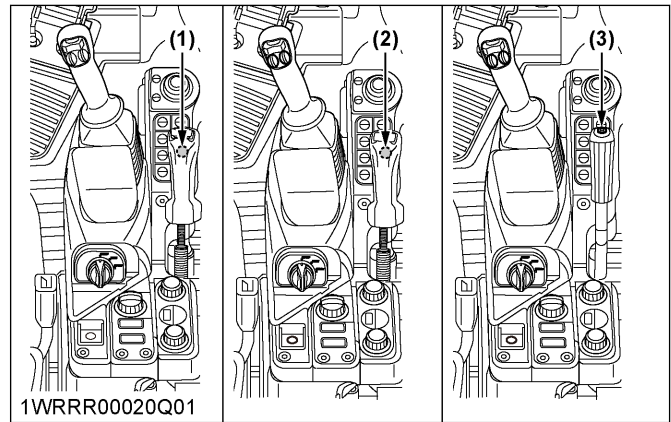

- (1) Travel speed switch [6-in-1 blade type]
- (2) Travel speed switch [Angle blade type]
- (3) Travel speed switch [Standard type]

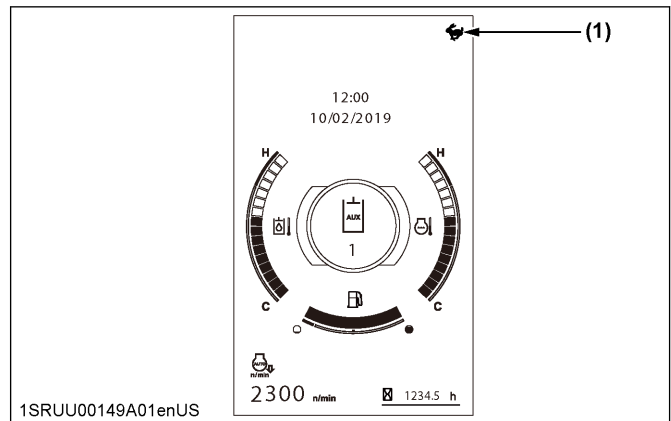

(1) Speed indicator light

NOTE :

- When activating the travel speed switch, it must be pushed down completely.
- Each time the travel speed switch is pressed, the travel speed is switched between low and high.

IMPORTANT :

- The travel speed automatically changes into first speed (low speed) when the drive resistance increases while traveling in second speed (high speed). Thereafter, when the resistance decreases, it returns to second speed.
- If a track is clogged with sand or gravel while working on soft ground, lift up the track with the help of the boom, arm, bucket, and dozer blade, and let the track rotate to remove the sand and gravel.

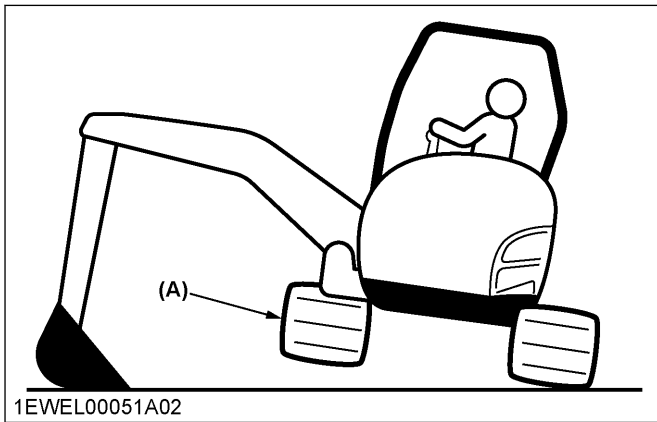

(A) Rotate to remove sand and gravel

! WARNING

To avoid personal injury or death:

- Do not push the dozer control lever into the float position as this will cause the machine to suddenly drop.

! DANGER

To avoid serious injury or death:

- Do not work under the machine in this condition.

INHIBIT DIESEL PARTICULATE FILTER (DPF) REGENERATION SWITCH

The Inhibit diesel particulate filter (DPF) regeneration switch (hereinafter referred to as the inhibit switch) disables the auto DPF regeneration cycle.

Activate this switch to turn off Auto DPF Regeneration when working around people, animals, plants, and flammable materials.

Certain work conditions may require the auto DPF regeneration cycle to be disabled.

- Press the inhibit switch once to turn off automatic regeneration mode.
- Press the inhibit switch once again to re-enable automatic regeneration mode.

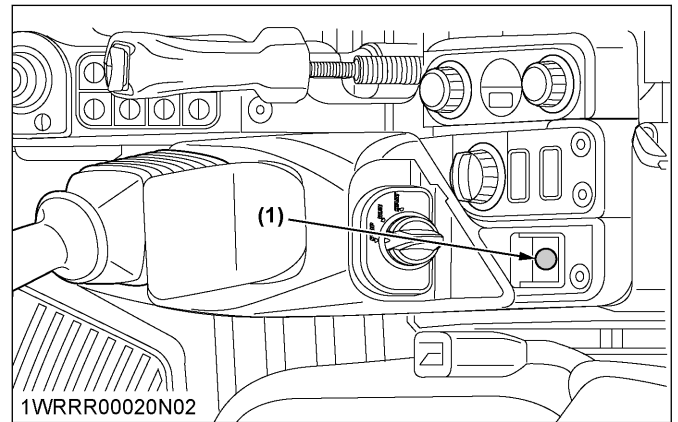

(1) Inhibit switch

BEACON LIGHT SWITCH

The beacon light switch comes standard on the machine. The beacon light itself must be installed separately. The coupler to connect the beacon light can be found behind the left speaker in a cab unit.

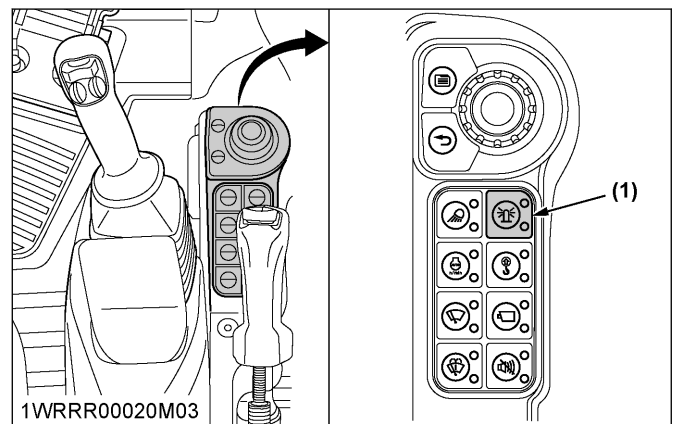

(1) Beacon light switch

ELECTRICAL OUTLET AND USB OUTLET

The maximum power of the electrical outlet is 120 W. If you require additional auxiliary electricity, contact your Kubota dealer for details.

IMPORTANT :

- The rated current of the connected load must not exceed 10 A.

The maximum output current of the USB outlet is 2 A.

[Canopy]

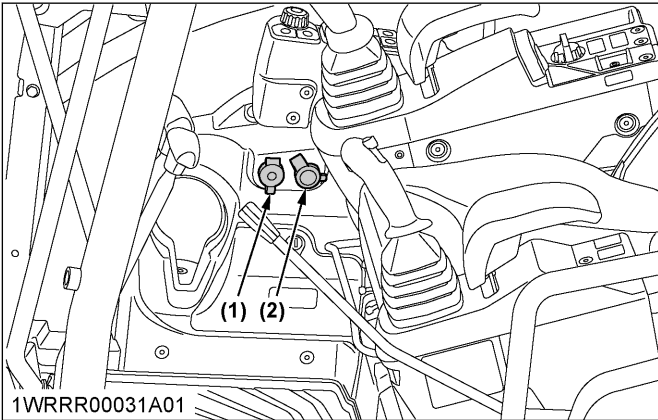

- 1WRRR00031A01
- (1) 12 V electrical outlet
 - (2) USB (Type-A) outlet

[CAB]

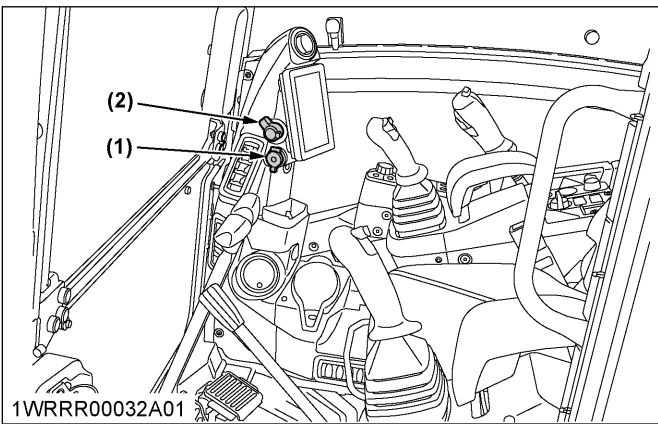

- 1WRRR00032A01
- (1) 12 V electrical outlet
 - (2) USB (Type-A) outlet

CONTROL PEDALS AND LEVERS

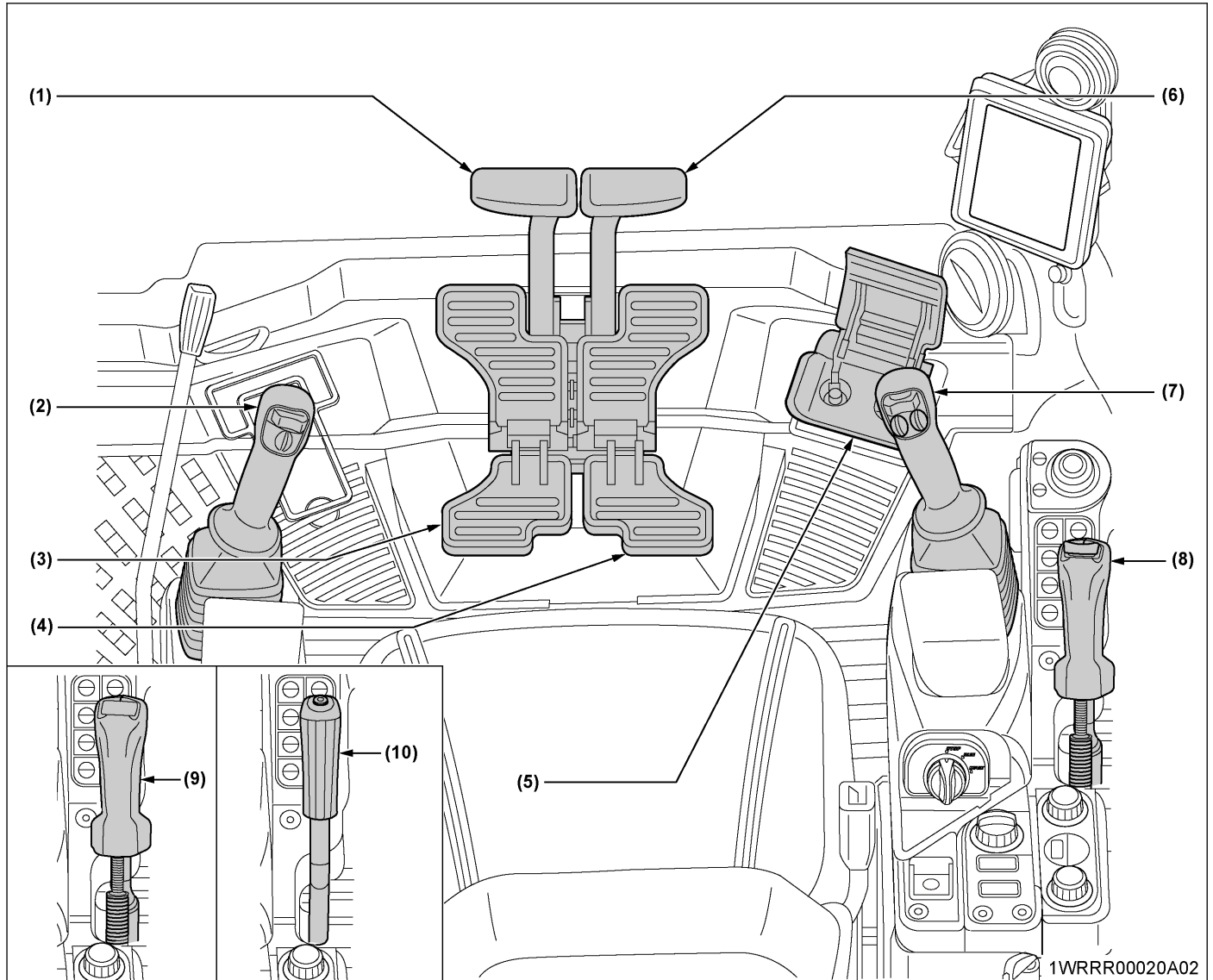

(1) Drive lever (left)	87	(6) Drive lever (right)	87
(2) Attachment control lever (left)	90	(7) Attachment control lever (right)	90
(3) Drive pedal (left)		(8) Dozer control lever [6-in-1 blade type]	90
(4) Drive pedal (right)		(9) Dozer control lever [Angle blade type]	90
(5) Boom swing pedal	92	(10) Dozer control lever [Standard type]	90

HANDLING THE PILOT CONTROL LOCK LEVER

WARNING

To avoid personal injury or death:

- Before exiting the machine, place the pilot control lock lever in the LOCK position.

The pilot control lock lever is located on the left side.

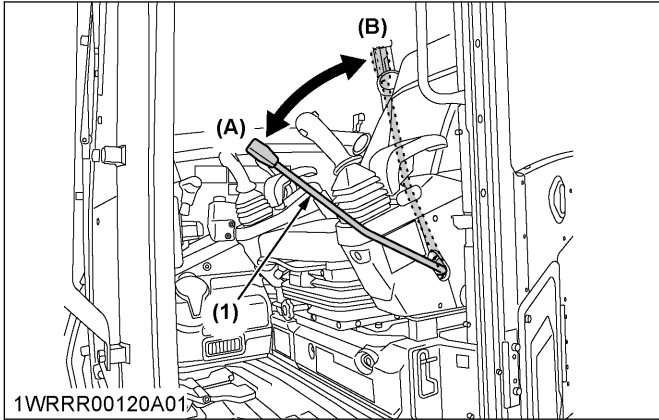

(1) Pilot control lock lever

(A) UNLOCK

(B) LOCK

CAB OPERATION

OPERATING THE WIPER AND WASHER

All cab models are equipped with a wiper/washer system.

IMPORTANT :

- Do not turn on the wiper switch while the windscreen is open. When you turn on the wiper while the windscreen is open, the wiper can hit the adjacent cab components causing damage to the wiper.
- In extremely cold weather conditions, make sure the wiper rubber does not stick to the window. This can damage the wiper rubber or the wiper motor.
- Only switch on the wiper when the window glass is wet. If necessary, switch on the washer system first.
- Do not operate the washer system if its reservoir is empty as running dry could damage the pump.

Wiper

1. Turn the starter switch to the **[RUN]** position.
2. Press the wiper switch to activate the windscreen wiper.
 - Press once and the wiper activates intermittently. The upper indicator lights up.
 - Press a second time and the wiper activates continuously. The lower indicator lights up.
 - Press a third time and the wiper stops. Both the upper indicator and the lower indicator go out.

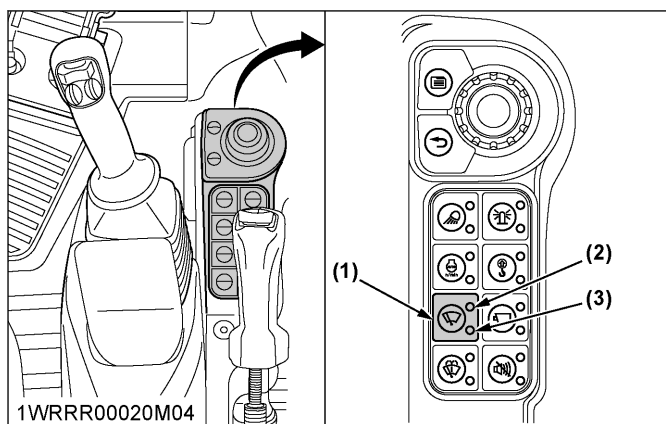

- (1) Wiper switch
(2) Upper indicator
(3) Lower indicator

Washer

1. Turn the starter switch to the **[RUN]** position.
2. Press the washer switch to activate the washer.

- The washer system runs for as long as the switch is held down. The indicator lights up.
- Hold down the switch for longer, and the wiper starts.
- Release the switch, and the wiper will swing several times before stopping.

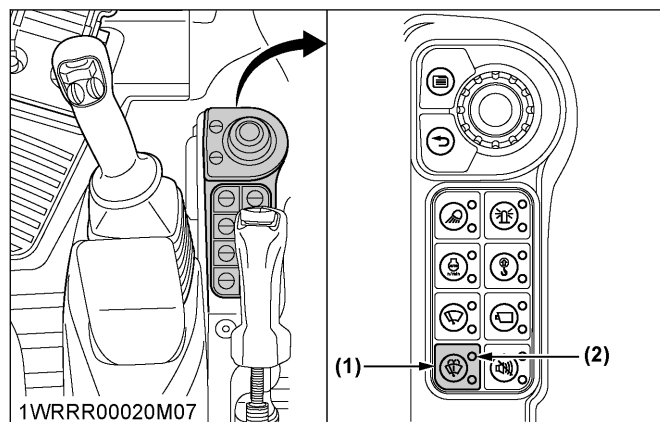

- (1) Washer switch
(2) Indicator

INTERIOR LAMP

To turn on the interior lamp, set the interior lamp switch to the **[ON]** position.

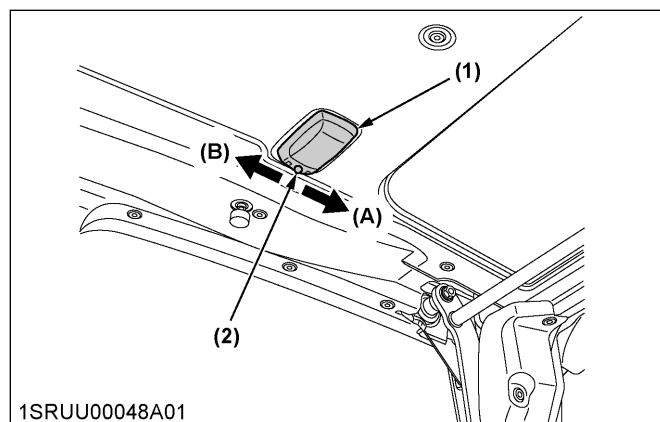

- (1) Interior lamp
(2) Interior lamp switch
(A) ON
(B) OFF

HEATER SWITCH

Turn the starter switch to the **[RUN]** position and turn the heater switch clockwise, the heater fan will be activated and the cabin will start to warm up. The heater has three position.

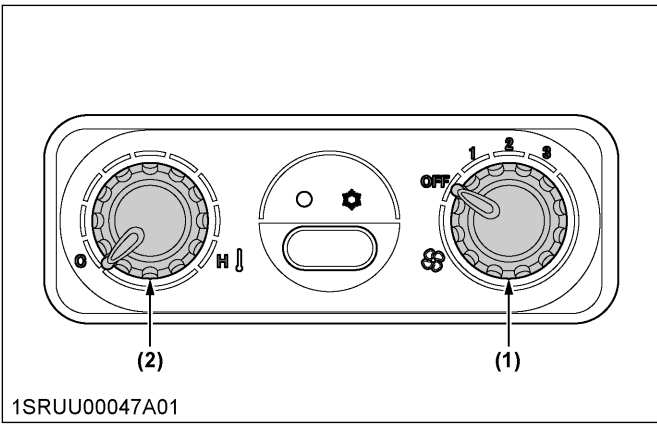

(1) Heater switch
(2) Temperature control dial

OPENING AND CLOSING THE CAB DOOR

Opening

1. Unlock the CAB door.
2. Pull the knob.
3. Open the CAB door fully until fixed into place.

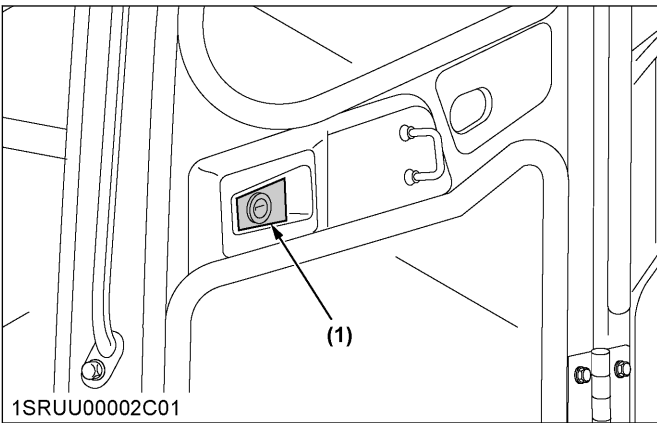

(1) Door knob (outside)

Closing

1. Push the release lever down.
2. Close the door.

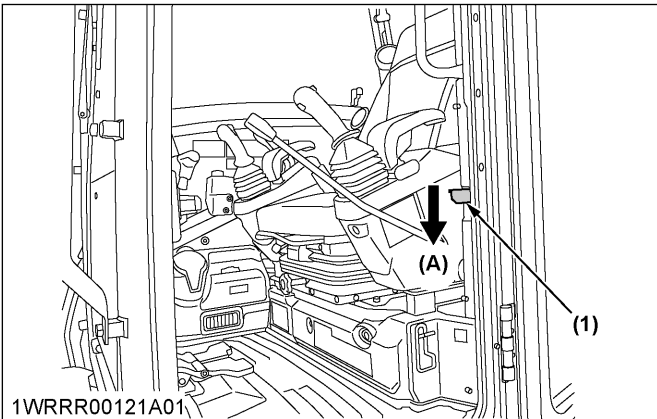

(1) Release lever (A) Push down

NOTE :

- Always lock the door when leaving the machine.

Opening from the inside

1. Push the release lever down.
2. Open the door.
3. To keep the door open, swing it to the fully locked position against the side of the machine.

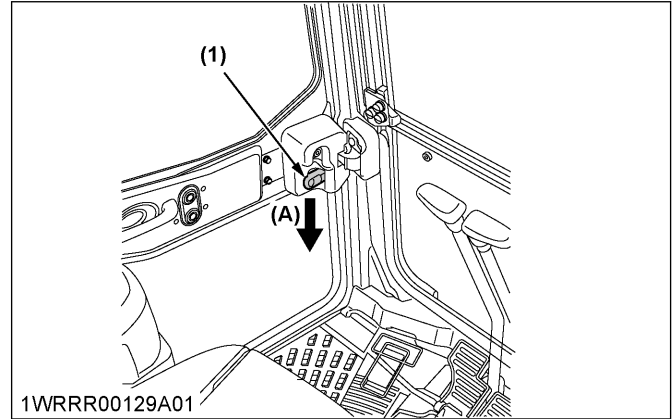

(1) Release lever (A) Push down

OPENING AND CLOSING THE FRONT WINDOW DOOR OF THE CAB

⚠ WARNING

To avoid personal injury or death:

- Keep hands and feet away from the area between the front window and CAB frame. Otherwise, the operator risks serious pinching or crushing injuries.
- Other people should stay away when opening the window.

To open and close the front window, take the following steps:

1. Push the lock levers located near the grip.

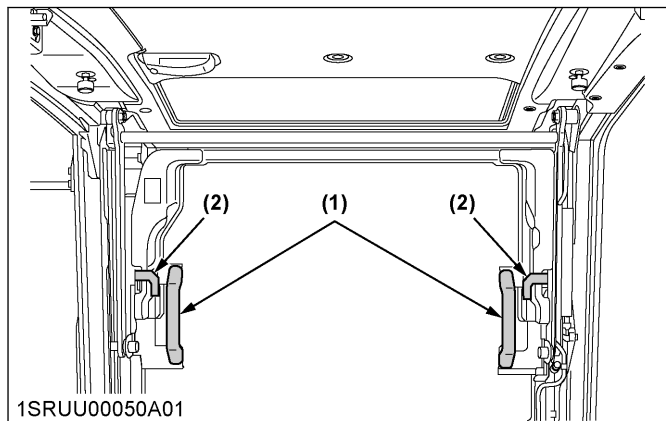

- (1) Grip
- (2) Lock lever

2. Hold the grips tightly with both hands. Pull the grip slightly upward and toward yourself to let the front window door slide inward.
3. Pull the front window door all the way to the lock at the back of the CAB.
4. To close the window, repeat the previous steps in reverse order.

OPENING AND CLOSING THE SIDE WINDOW OF THE CAB

1. Press the grip upwards to release the lock.
2. Pull the side window open towards the rear or towards the front.

NOTE :

- The window can be locked into a halfway open position by fitting the lock hooks into the window sash grooves. The hooks should be locked into one of the grooves during operation.

3. To close the side window, slide it forward or backward until the hook locks into either the front or the rear sash groove.

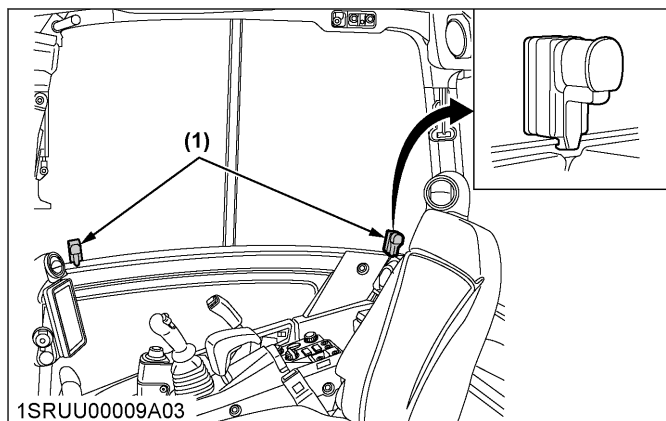

- (1) Grip

REMOVING THE FRONT WINDOW BASE

1. Open the front window and fold the backrest completely forward.
2. Lift the front window base upwards and remove it from the window frame.

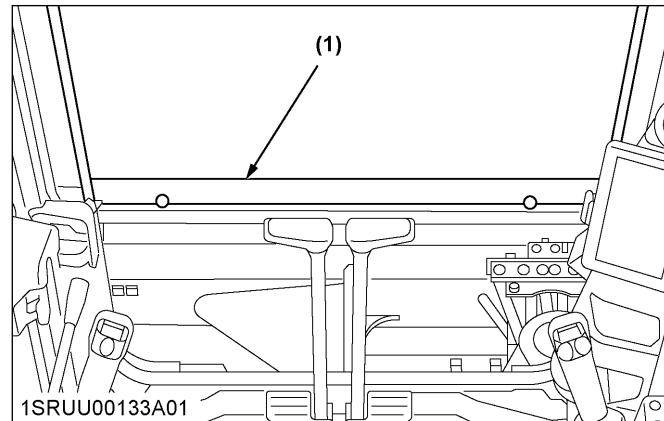

- (1) Front window base

3. To reattach, carefully insert the front window base into the fixings at the cab back wall and into the locking mechanism until it snaps into place.

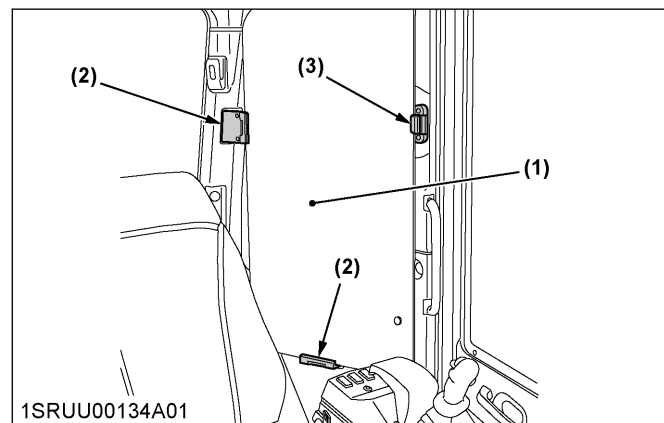

- (1) Front window base
- (2) Fixing
- (3) Locking mechanism

! WARNING

To avoid personal injury:

- Make sure that the glass pane is properly engaged in the locking mechanism. If the glass pane is not locked securely, it can fall down and cause severe injuries.

EMERGENCY HAMMER

! WARNING

To avoid personal injury or death:

- When breaking the window pane, close your eyes and cover them with your arm.

The emergency hammer is used for breaking a window pane if the window cannot be opened quickly enough when escaping from the CAB.

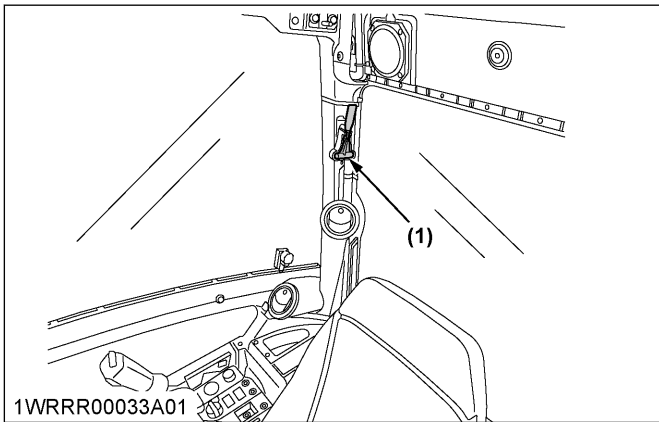

(1) Emergency hammer

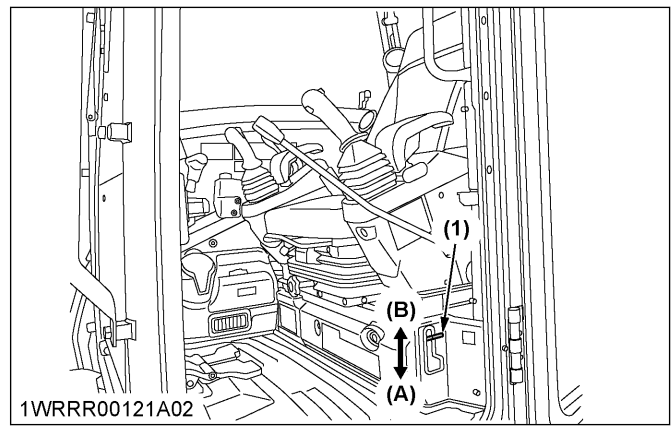

(1) Inlet selector lever (A) FRESH AIR INLET (B) INNER AIR RECIRCULATION

AIR CONDITIONER

IMPORTANT :

- Never block all of the air outlets because a system malfunction may occur.

1. Air flow

Air in the CAB and fresh air introduced into the CAB flows as shown in the following figure. Adjust the eight air outlet ports to obtain the desired condition.

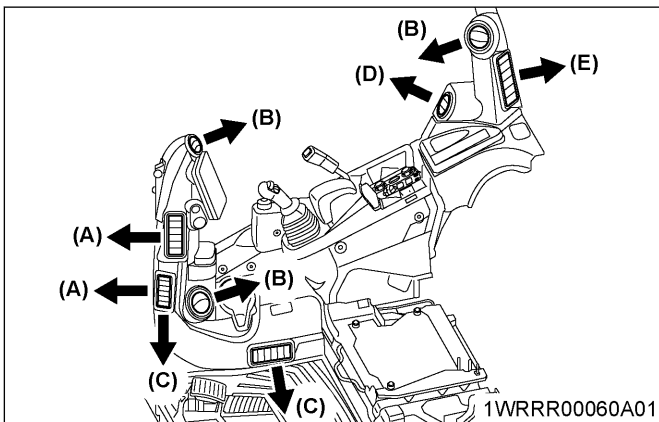

(A) FRONT WINDOW (B) CHEST AREA (C) FOOT AREA (D) SIDE WINDOW (E) BACKWARD

Set the inlet selector lever to the desired position.

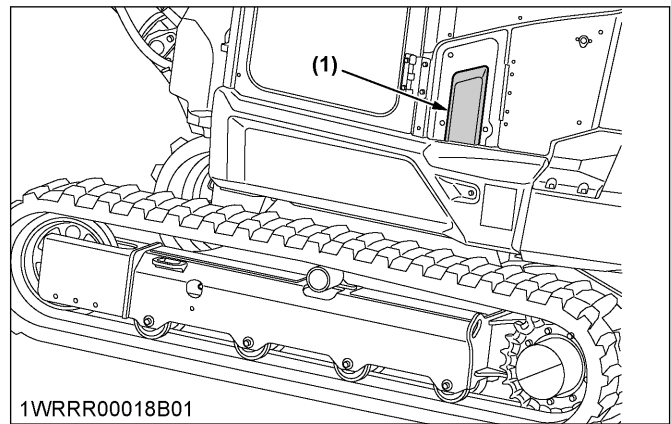

(1) FRESH AIR INLET

IMPORTANT :

- Do not allow water to enter the fresh air inlet while washing the machine.
- The air-conditioner unit proper is not waterproof.

2. Air control vent

NOTE :

- If the window fails to defrost in extreme conditions or becomes cloudy when dehumidifying the cab, remove the moisture with a soft cloth.

2.1 Front air outlet

The front air outlets can be independently adjusted as required. To defrost the front window, rotate the outlets toward the front window.

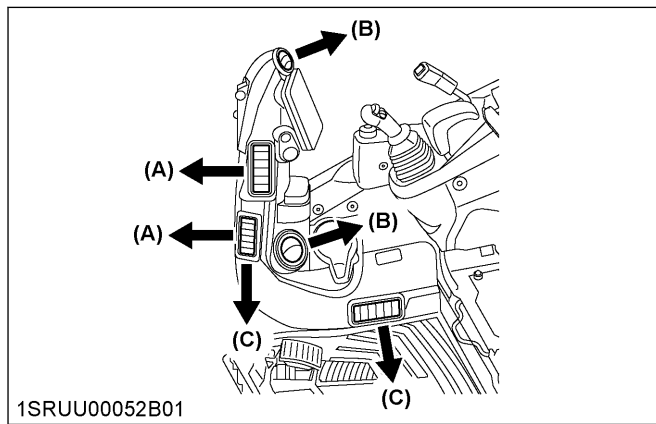

1SRUU00052B01

- (A) FRONT WINDOW
 (B) CLOSED
 (C) FOOT AREA

3. Control panel

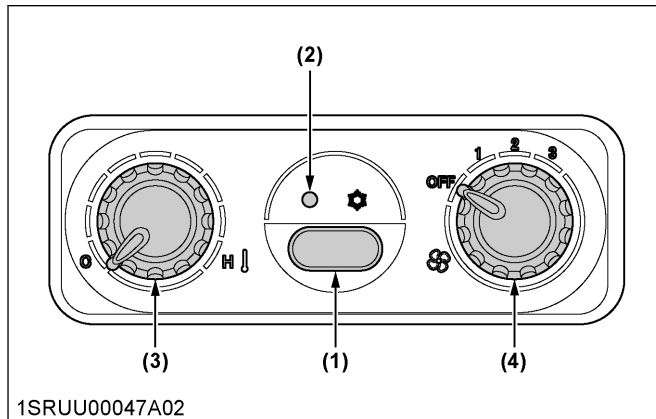

1SRUU00047A02

- (1) Air conditioner switch
 (2) Indicator light
 (3) Temperature control dial
 (4) Blower switch

Air conditioner switch and indicator light

Push this switch to activate the air conditioner. An indicator light will light up when the switch is set to **[ON]**. Push the switch again to turn the air conditioner off and the indicator light will go off.

Temperature control dial

Set this dial at the desired position to obtain the desired air temperature. Turn the dial to the left to obtain cooler air. Turn it to the right to obtain warmer air.

Blower switch

The air volume can be switched between 3 positions. At the **[3]** position, the maximum air volume is obtained.

4. Operation

Heating

1. Adjust the blower (**[1]**, **[2]** or **[3]**) switch and the temperature control dial to achieve the desired temperature level.

Dehumidifying-heating

1. Press and turn on the air conditioner switch.
2. Turn on the blower (**[1]**, **[2]** or **[3]**) switch.
3. Adjust the temperature control dial to the "COOL" or an intermediate position to achieve the desired temperature level.

NOTE :

- Close the door while the air conditioner is on, otherwise you may overload the compressor.

Cooling

1. Press and turn on the air conditioner switch.
2. Turn on the blower (**[1]**, **[2]** or **[3]**) switch.
3. Adjust the temperature control dial to the "COOL" or an intermediate position to achieve the desired temperature level.

Defrosting or demisting

To defrost or demist the windshield, take the following steps.

1. Open the front air outlet and direct it to the windshield.
2. Set the blower switch and the temperature control dial to the **[3]** and "WARM" (rightmost) positions, respectively.

RADIO

BLUETOOTH MICROPHONE

The Bluetooth microphone is used to make hands-free calls.

(See Operating Bluetooth mode on page 59 and Call control for Bluetooth-connected cell phone on page 62 for instructions on how to use the hands-free phone)

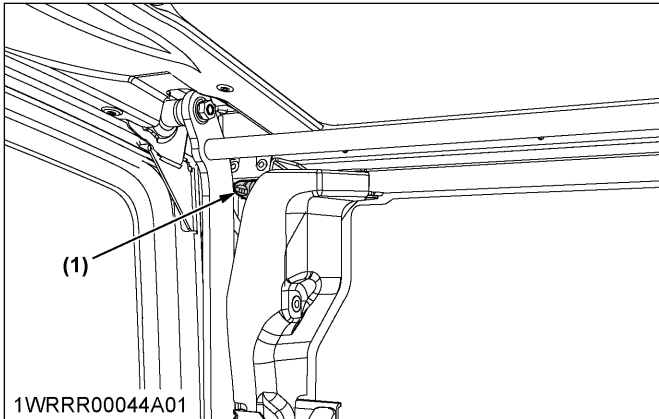

(1) Bluetooth microphone

NOTE :

- To use the Bluetooth microphone, settings on your mobile phone may be required. See the operating manual of your mobile phone for details of connecting the device.

IMPACT OF BLUETOOTH

Bluetooth specifications and supported profiles

Supported Bluetooth specifications

Version : 5.0

Class : 1

Supported profiles: A2DP, AVRCP, HFP

Number of registered pairings allowed: Maximum 5

NOTE :

- We do not guarantee that all Bluetooth devices can be operated with this machine.
- In case the Bluetooth of the connected device is older than recommended version or incompatible, the Bluetooth functions may not work properly.
- This product complies with the legally stipulated technical standards regarding the required standards for radio equipment and EMC regulations for radio equipment. The sticker affixed on the products is the proof. Do not remove the sticker.

- Disassembling or modification of this product is punishable by law.

IMPORTANT :

- Do not use Bluetooth-connected mobile devices near the radio unit. If the Bluetooth-connected mobile device gets too near, the sound quality and connection will deteriorate.

Persons using a pacemaker or other electrical device for medical treatment,

note of the following points regarding radio waves in Bluetooth communication.

WARNING

To avoid personal injury or death:

- The antenna for Bluetooth communication is built in the radio unit. With the exception of an implantable cardiac pacemaker, implantable biventricular pacing pulse generator, and implantable cardioverter defibrillator, if you are using an electrical device for medical treatment, check in advance with your physician and the manufacturer of the medical device about the impact of radio waves. Radio waves may affect the operation of electrical devices for medical treatment.

Bluetooth connected mobile devices

A Bluetooth connected mobile device is used for wireless (Bluetooth) communication with this machine.

For example, hands-free mobile use is possible even when your device is in your pocket.

NOTE :

- If the Bluetooth connected mobile device is used simultaneously with other radio devices, it can adversely impact their communication.
- If Wi-Fi®, Miracast® and Bluetooth-connected mobile devices using the 2.4 GHz band radio communication are used simultaneously with this machine, it can adversely impact their communication.
- Batteries of Bluetooth-connected mobile devices will drain faster due to Bluetooth connection.
- The frequency band used by Bluetooth-connected mobile devices are used for industrial use such as microwave ovens, scientific use, and use in medical devices, in addition to the following radio stations.

- On-site radio stations for moving object identification used in factory production lines, etc. (radio stations that require a license)
- Specified low-power radio stations (radio stations that do not require a license)
- Amateur radio stations (radio stations that require a license)

(The 3 types of radio stations mentioned above are hereinafter abbreviated as "other radio stations")

Before using a Bluetooth-connected mobile device, ensure there are no "other radio stations" operating nearby.

In the unlikely event of hazardous radio interference from a Bluetooth-connected mobile device to "other radio stations", immediately change the location of use to avoid radio interference.

- The frequency band used by Bluetooth-connected mobile devices is the 2.4 GHz band. FH-SS modulation is used as the modulation method.

The expected giving interference distance is 10 m or less.

Bluetooth-connected mobile devices use the entire bandwidth and can evade the bandwidth of moving object identification equipment.

Hands-free

By connecting an operation-confirmed Bluetooth-connected mobile device* (hereinafter referred to as "mobile phone") to this machine, you can use the phone functions of "calling" and "receiving calls" without directly operating the mobile phone. This is called the hands-free function.

To connect to this machine, use a mobile phone that is compatible with the specifications of this machine. However, some functionality may be limited depending on the mobile phone model.



WARNING

To avoid personal injury or death:

- For safety reasons, when using a mobile phone in hands-free mode, the driver should not operate the mobile phone while driving.
- Stop the vehicle at a safe place and make your call. If you receive a phone call while driving, drive carefully and keep the call brief.

IMPORTANT :

- Do not leave behind mobile phones in the cab. The temperature inside the cab will increase under the blazing sun, etc., which may cause failure.

Situations when the hands-free function cannot be used

- Hands-free operation is not possible in the following cases:
 - When outside the calling area
 - When outgoing calls are restricted, such as when the line is busy
 - When on an emergency call
 - When the mobile phone is dial-locked
 - When the mobile phone is in use, such as when data communication is in progress
 - When the mobile phone is malfunctioning
 - When the mobile phone is not connected to this machine
 - When the mobile phone battery is low
 - When the mobile phone is switched off
 - When the mobile phone is not set to hands-free mode
 - And also, when the mobile phone is not usable

NOTE :

- If there is a contract for three-way calling, deactivate three-way calling on the mobile phone before use.

Calls

Use the microphone for calls.

- Audio such as incoming call notifications and on-call voice is output from the speaker.
- Audio sounds are muted (silenced) when voice, ring tone, etc. are output in hands-free mode.

NOTE :

- **Adjust the receiving volume as low as possible. If the volume is too loud, the other person's voice may be heard outside the vehicle or they might hear an echo during the call.**
- **In the following cases, it may be difficult for the other party to hear your voice.**
 - When driving on rough roads
 - When the window is open
 - When the air conditioner is noisy
 - When a cell phone is placed close to the microphone
- The sound quality may deteriorate (noise, echoes, etc.) due to the cell phone or network used.

IMPORTANT :

- Do not touch the microphone or insert pointed objects into it. This may cause the microphone to malfunction.

COMPLIANCE STATEMENT

1. FCC Statement

This device complies with part 15 of the FCC Rules. Operation is subject to the following two conditions: (1)

This device may not cause harmful interference, and (2) this device must accept any interference received, including interference that may cause undesired operation.

FCC CAUTION

Changes or modifications not expressly approved by the party responsible for compliance could void the user's authority to operate the equipment.

U.S.A. : KUBOTA TRACTOR CORPORATION
1000 Kubota Drive, Grapevine, TX 76051
Telephone : (817)756-1171

2. ISED Canada Statement

This device contains licence-exempt transmitter(s)/ receiver(s) that comply with Innovation, Science and Economic Development Canada's licence-exempt RSS(s). Operation is subject to the following two conditions:

1. This device may not cause interference.
2. This device must accept any interference, including interference that may cause undesired operation of the device.

L'émetteur/récepteur exempt de licence contenu dans le présent appareil est conforme aux CNR d'Innovation, Sciences et Développement économique Canada applicables aux appareils radio exempts de licence. L'exploitation est autorisée aux deux conditions suivantes :

1. L'appareil ne doit pas produire de brouillage;
2. L'appareil doit accepter tout brouillage radioélectrique subi, même si le brouillage est susceptible d'en compromettre le fonctionnement.

Canada : KUBOTA CANADA LTD.
1155 Kubota Drive, Pickering, Ontario L 1X 0H4,
Canada
Telephone : (905)294-7477

OPERATING THE ENGINE

WARNING

To avoid personal injury or death:

- Read and understand the safe operation section.
(See **SAFE OPERATION** on page 7.)
- Obey the safety labels on the machine.
- To avoid the danger of carbon monoxide poisoning, do not operate the machine indoors without proper ventilation.
- Always start the engine from the operator's seat. Do not start the engine while standing next to the machine. Before starting the engine, sound the horn to alert people standing nearby.

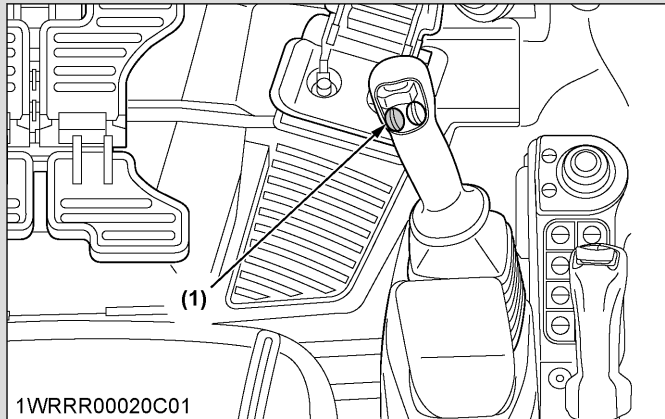

(1) Horn switch

IMPORTANT :

- Do not use starting fluid or ether.
- To prevent overloading the battery and starter, avoid engaging the starter for more than 10 seconds.
- If the engine does not start in 10 seconds, please wait 20 seconds or more, before attempting to restart.

STARTING THE ENGINE

WARNING

To avoid personal injury or death:

- The operator should not depend solely on the warning lamps, but should always conduct the routine checks.
(See **MAINTENANCE INTERVALS** on page 111.)

The engine can be started by entering a registered password using the keypad.

Manage the following 2 password types.

User password

This is a 4-digit password which is required in order to start the engine.

Up to 10 user passwords can be registered at a time.

Machine password

This is a 6-digit password which is required in order to register, change, or delete user passwords.

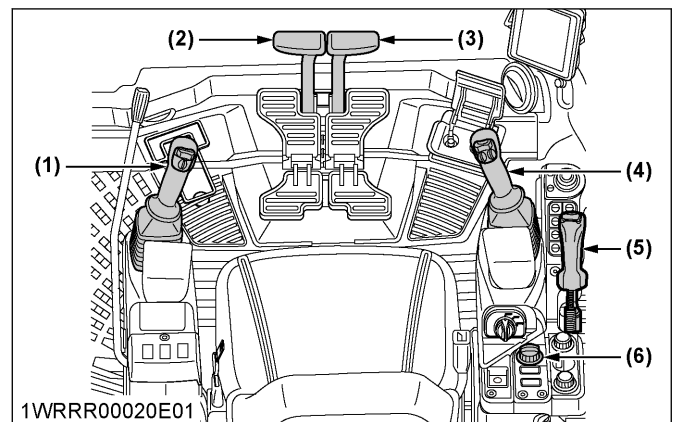

1. Before starting the engine, make sure that all control levers are in the neutral position.



- (1) Attachment control lever (left)
- (2) Drive lever (left)
- (3) Drive lever (right)
- (4) Attachment control lever (right)
- (5) Dozer control lever
- (6) Throttle potentiometer

2. Pull the pilot control lock lever all the way back to the LOCK position.

OPERATING THE ENGINE

3. Put the throttle potentiometer in the middle, between  and  symbols. The Auto Idle control switch is in the "OFF" position. (See AUTO IDLE (AI) OPERATION on page 103.)

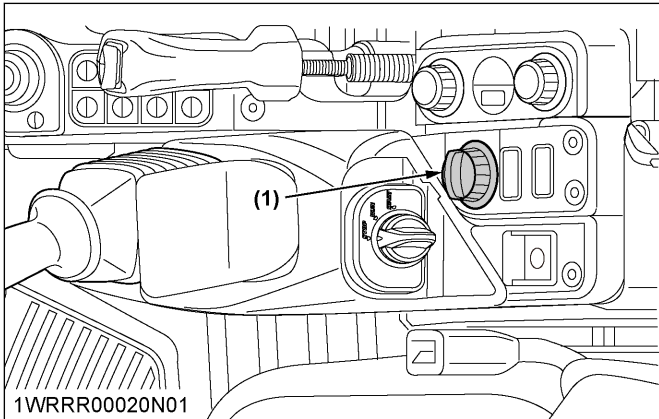

(1) Throttle potentiometer

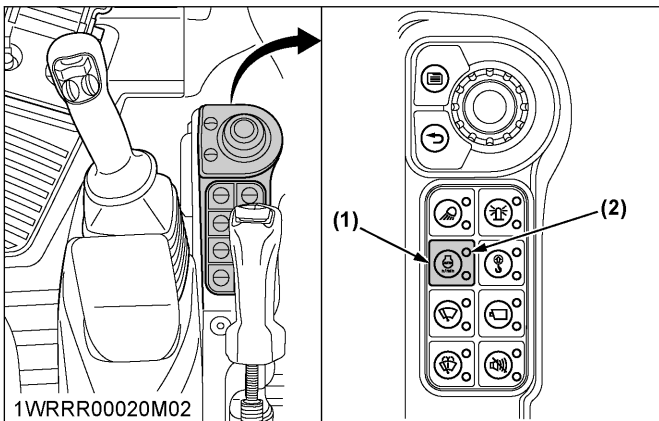

(1) Auto Idle control switch
(2) Auto Idle lamp

4. Turn the starter switch to the [RUN] position.

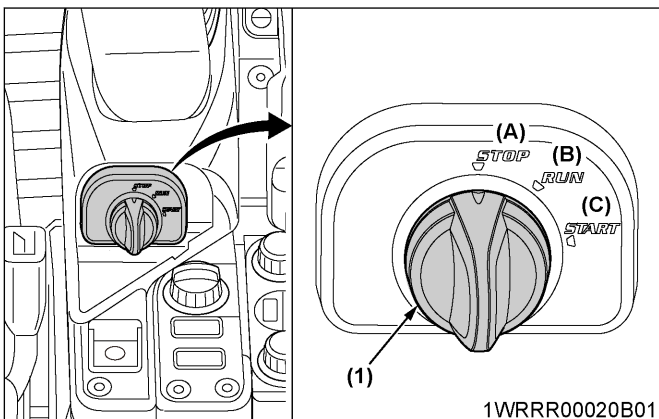

(1) Starter switch
(A) STOP
(B) RUN
(C) START

5. Enter a user password using the keypad. Once 4 digits have been entered, authentication commences.

When the user password has been verified, the normal screen appears and the engine can be started.

(For details on registering user passwords, see Registering new user passwords on page 50.)

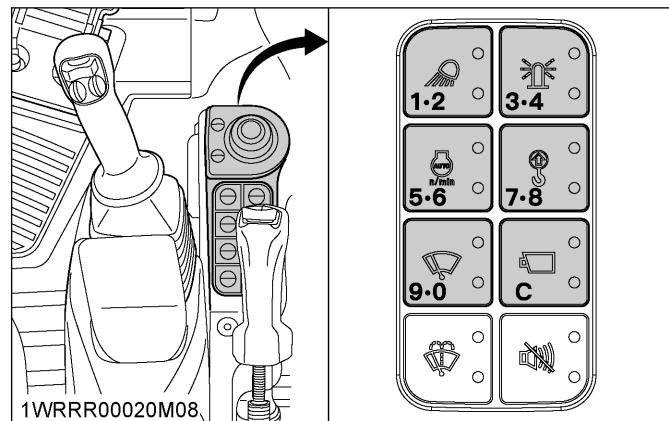
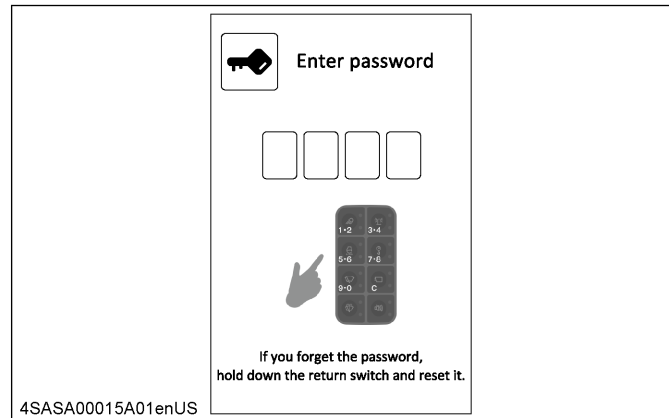

NOTE :

- In the event of a mistaken entry, it is possible to delete the entry by pressing "C" (Clear) before entering the fourth digit, and then re-enter the password.
- If password authentication fails 6 times, the alarm sounds for 30 seconds. (The alarm continues to sound even if the starter switch is turned to the [STOP] position.)
- In the event of a forgotten user password, go to the normal screen by holding down the return switch while on the user password entry screen, and either change the password or register a new password. When starting the engine after registering or changing a user password, turn the starter switch to the [STOP] position, return it once again to the [RUN] position, and enter the user password.
- If the password has not been authenticated, the pilot lock lever does not unlock when lowered, and all but a few of the electrical components are inoperable.

- The password stays authenticated for 3 minutes after turning the starter switch to the [STOP] position. Therefore, after stopping the engine, it is possible to turn the starter switch back to the [RUN] position and perform tasks such as restarting the engine and releasing pressure from the hydraulic system without re-entering the password, as long as no more than 3 minutes has passed.
- If the display is left on the password entry screen for a fixed amount of time, all but a few of the electrical components automatically turn off in order to preserve the battery (and the display also goes dark). When starting the engine, turn the starter switch to the [STOP] position, return it once again to the [RUN] position, and enter a user password.

IMPORTANT :

- If the electrical components automatically turn off after leaving the display on the password entry screen for a fixed amount of time, do not leave the machine in this state for an extended period of time.
6. Hold the starter switch at the [RUN] position until the message “Preheating” disappears from the screen.

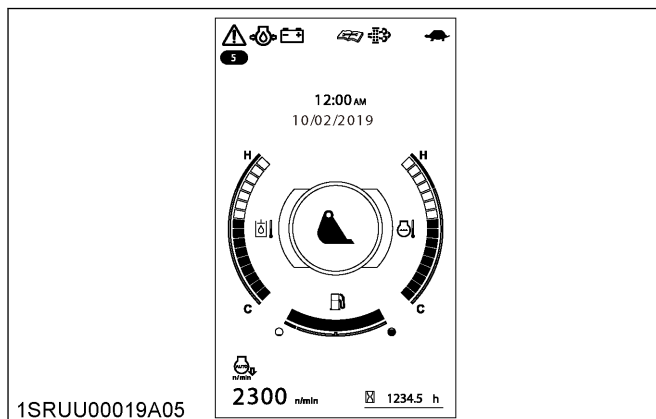

7. Now make sure that the and marks appear on-screen. If they do not appear, the system has malfunctioned. Contact your local Kubota dealer for repairs.
8. Turn the starter switch to the [START] position and release it after the engine has started.
9. Check if all warning lamps have gone out. Should a warning lamp still be lit up, stop the engine and check for the cause.

IMPORTANT :

- The starter motor draws a large amount of current. Avoid running it for longer than 10 seconds continuously.

If the engine fails to start within 10 seconds, turn the starter switch to the [STOP] position, wait for 20 seconds or longer and repeat steps 5 through 7.

- If the battery is dead and must be connected to another battery with jumper cables, use a 12 V battery. Never use 24 V batteries.

NOTE :

- If you keep the pilot control lock lever in the UNLOCK position and try to start the engine, “Up lock lever” appears on the meter panel and the engine will not start. Before starting the engine, make sure that the pilot control lock lever is set at the LOCK position.

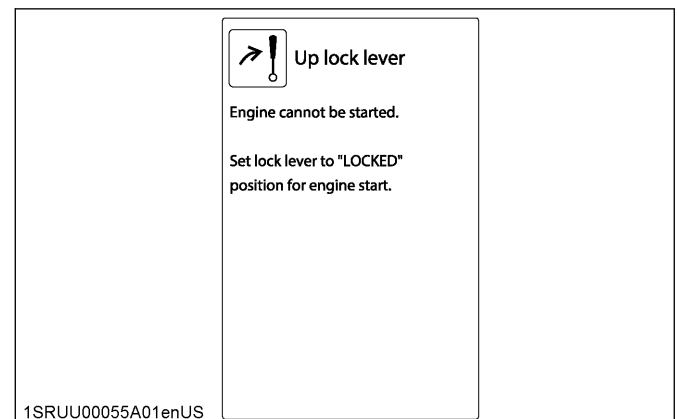

- When the engine starts, the meter may momentarily turn off and a beep may sound. This is not a problem.

STARTING THE ENGINE UNDER COLD CONDITIONS

WARNING

To avoid personal injury or death:

- Make sure that the pilot control lock lever is in the LOCK position during warm-up.

Make sure the Auto Idle is turned off (lamp off).

1. Pull the pilot control lock lever all the way back to LOCK position.
2. Turn the throttle potentiometer toward (high speed) position.
3. Turn the starter switch to the [RUN] position. Hold the switch at this position until the message “Preheating” disappears from the screen.
4. Turn the starter switch to the [START] position.
5. Once the engine starts, release your hand from the switch. The switch will return to the [RUN] position.
6. If the engine fails to start, turn the starter switch to the [STOP] position and repeat steps 5 through 7.

IMPORTANT :

- Let the engine warm up after start-up for approximately 10 minutes under no load conditions. If the hydraulic fluid temperature is too low, the operation will be affected. Do not operate the excavator under full load until the engine has sufficiently warmed up.

NOTE :

- If the water temperature is low, the engine increases its idle rotation speed and warms up quickly when the following conditions are met:
 - The [Heat up function] in the meter settings is set to [ON].
 - The pilot control lock lever is in the LOCK position.
 - The throttle potentiometer is set to the lowest speed.

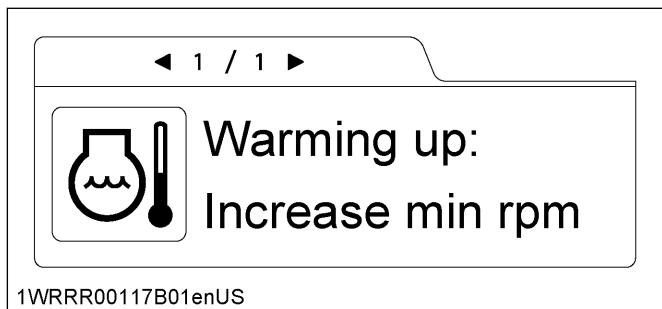

STARTING WITH AN AUXILIARY BATTERY

WARNING

To avoid personal injury or death:

- Battery gases can explode. Do not smoke and keep sparks and flames away.
- Do not start the engine with an auxiliary battery if the machine battery is frozen.
- Do not connect the black jumper cable to the negative (-) terminal of the machine's battery.
- Wear eye protection and rubber gloves.

IMPORTANT :

- This machine has a negative (-) ground 12 V starting system.
- Use only the same voltage when using an auxiliary battery.
- Using a higher voltage will cause damage to the electrical system. When using an auxiliary battery, only the compatible (same) voltage is permitted.

Observe the following guidelines when starting with an auxiliary battery.

1. Bring another machine with the same battery voltage as close as possible to the machine.

IMPORTANT :

- **The machines must not come in contact with each other.**
2. Set the levers and pedals of both machines in their neutral positions and put the pilot control lock lever in the LOCK position.
 3. Open the side cover. (See Opening and closing the side cover on page 119.)
 4. Ensure the vent caps are securely in place (if equipped).
 5. Connect the terminal of the red jumper cable with the plus (+) terminal of the low battery and connect the other end of the cable to the plus (+) terminal of the auxiliary battery.
 6. Connect the black negative cable to the minus (-) terminal of the auxiliary battery.
 7. Connect the other end of the black negative cable (coming from the auxiliary battery) to the machine frame as far away as possible from the low battery.
 8. Start the engine of the helping machine and let it run for a while. Start the machine with the low battery.
 9. Disconnect the jumper cables in the reverse sequence (steps 7, 6, 5).

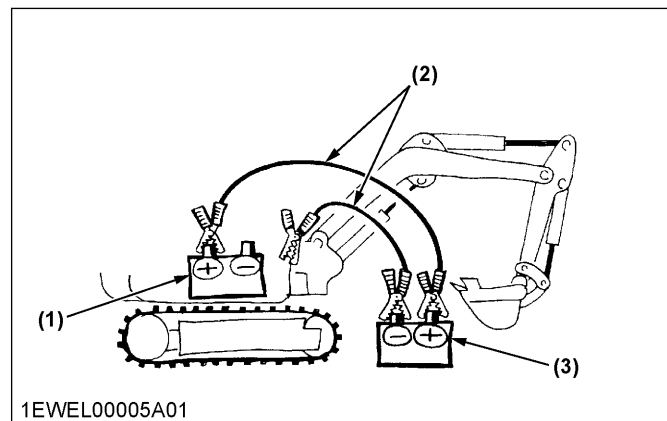



1EWEL00005A01

- (1) Low battery
- (2) Jumper cables
- (3) Auxiliary battery

CHECK POINTS AFTER STARTING THE ENGINE

Check the following points after starting the engine, but before starting operation:

- Put the throttle potentiometer in the middle between  and  symbols and let the engine idle for approximately 5 minutes. This allows the engine lubricant to warm up and reach every part of the engine.
- Once the engine has warmed up, check:
 - the warning lamp “*Engine oil pressure*” has gone out.
 - the warning lamp “*Battery charge*” goes out when engine speed is increased.
 - the color of the exhaust is normal and no abnormal noises or vibrations are heard or felt.
 - no fluid is leaking from pipes or hoses.

IMPORTANT :

- Stop the engine immediately if any of the following conditions occur:
 - The engine's rpm increases or decreases suddenly.
 - Sudden abnormal noises are heard, such as engine knocking.
 - Exhaust fumes are black.
 - Warning lamp for engine oil lights up during operation.
- In such cases, the machine must be checked and serviced by your local Kubota dealer.

STOPPING THE ENGINE

**WARNING**

To avoid personal injury or death:

- Lower all work attachments to the ground.

- Place the bucket and dozer on the ground.
- After slowing the engine to idle, turn the starter switch to the [STOP] position.
- Set the pilot control lock lever to the LOCK position.

1. Engine stop button

The engine stops when the starter switch is turned to the [STOP] position. If the engine does not stop, pull the stop button to stop the engine.

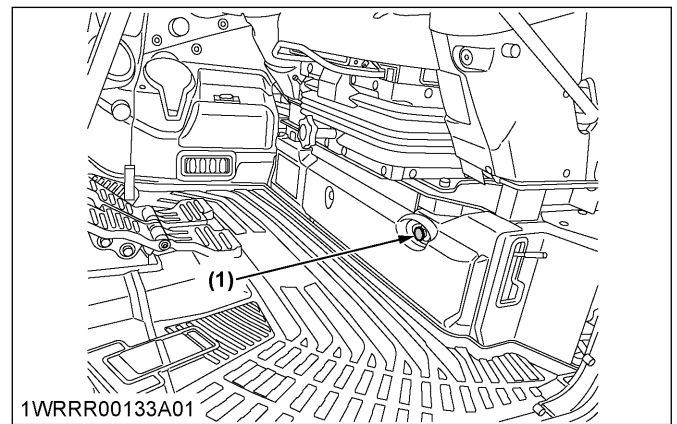

(1) Stop button

IMPORTANT :

- Return the stop button to its original position after the engine stops.

NOTE :

If the engine stop button is activated, a message will appear on the display as shown in the following image.

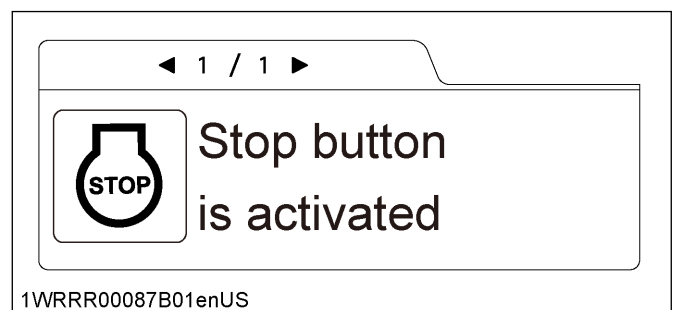

2. Overheating countermeasures

**WARNING**

To avoid personal injury or death:

- Do not open the radiator cap during operation or immediately after engine shutdown. Otherwise, steam or very hot coolant may escape and cause scalding. Make sure the radiator has cooled down enough before opening its cap.

If the coolant temperature rises close to, or above, the boiling point ([H] on the coolant temperature gauge, overheat condition), take the following steps:

- Stop operating the machine and relieve the engine of any load.
- Do not shut off the engine suddenly. Before shutting off the engine, keep it idling under no load for about 5 minutes.
- Stay away from the engine for 10 minutes or until the steam overflow stops.

4. Be sure that there is no danger of getting scalded. Check and remove the cause of the overheat. (See TROUBLESHOOTING OF THE ENGINE AND OTHER SYSTEMS on page 156.) Once the trouble is resolved, the engine may be restarted.

DPF REGENERATION



WARNING

To avoid personal injury or death:

- Read and understand the **Safe operation section of this manual.**

This machine is equipped with a DPF (diesel particulate filter) muffler.

The diesel particulate filter serves to trap particulate matters (PM) that are contained in exhaust gases and to automatically burn (DPF regenerate) these matters. In the regeneration, buzzer sounds and warning light blink and display shows messages. Follow the instructions.

(See AUTOMATIC DIESEL PARTICULATE FILTER (DPF) REGENERATION on page 187.)

OPERATING THE EXCAVATOR

OPERATION OF A NEW MACHINE

The operation and maintenance of a new machine impacts its life span. Your new machine has been carefully checked and tested before leaving the factory. In spite of this, all movable components must be run-in during the first 50 work hours. Do not work with full rpm and full loads during this period. It is most important to run-in your machine properly in order to achieve its full performance and longevity. During the running-in, the following points should be adhered to in all cases.

Do not work with full engine rpm or full loads during the first 50 working hours

- Let the engine warm up sufficiently in the cold season.
- Do not let the engine rev-up more than necessary except the DPF regeneration.

Oil change in the run-in stage

The lubrication oil plays a specific and important role during the run-in phase of the machine. The numerous movable parts are not yet run-in, so many fine metal particles are generated and cause damage and shorten the life of many components. Pay attention to the oil-change intervals and complete them sooner rather than later.

Details regarding oil change intervals can be found in a different section.

(See Changing the engine oil on page 137.)

PREPARATIONS BEFORE STARTING THE MACHINE

1. Adjusting the operator's seat



WARNING

To avoid personal injury or death:

- Make sure that the seat is completely secured after each adjustment.

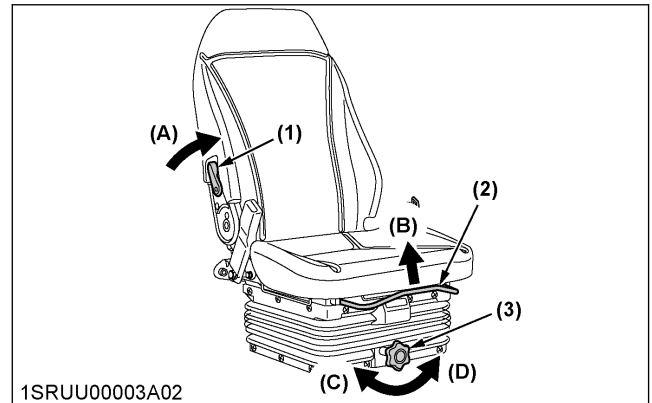

- 1SRUU00003A02
- (1) Backrest tilt adjust lever
(2) Travel adjust lever
(3) Weight adjust lever

- (A) UNLOCK
(B) UNLOCK
(C) TO INCREASE TENSION
(D) TO DECREASE TENSION

Tilt adjustment

Take the load off the backrest and pull the backrest tilt adjust lever in the direction of (A). Set the backrest to the desired sitting position and release the lever. The backrest should be adjusted so that the operator can safely operate the control levers with the back resting completely on the backrest.

Travel adjustment

Pull the travel adjust lever in the direction of (B) and slide the seat backward or forward, as required. The seat will lock into position when the lever is released.

Weight adjustment

Turn the weight adjust lever to achieve the optimum suspension setting.

Height adjustment

The seat height can be adjusted to 3 positions. To adjust the seat height, slowly raise the seat until it automatically engages in the next stop.

When the seat is raised over the highest stop, it will be lowered automatically to the lowest position again.

2. Using the seat belt



WARNING

To avoid personal injury or death:

- Always use the seat belt with a ROPS and OPG protection structure. Adjust the operator's seat to the optimal position and buckle it up.
- Always fasten the seat belt securely before starting the engine.

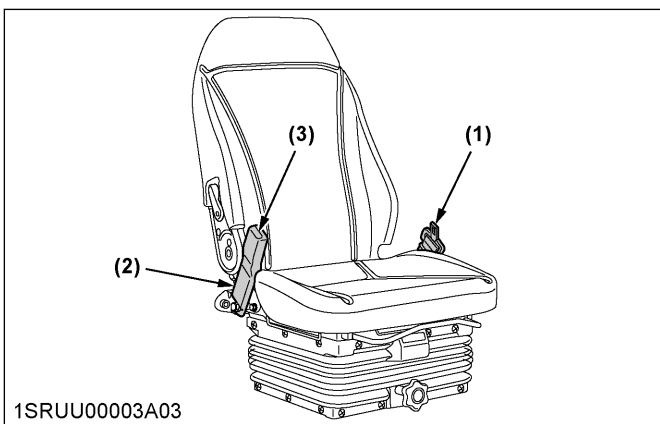

- (1) Seat belt
- (2) Socket
- (3) Button

Fastening the seat belt

1. Pull the seat belt from the retractable (left) side of the operator's seat.
2. Insert the fixture of the seat belt into the socket at the right side of the operator's seat until the fixture clicks deep into position.

Releasing the seat belt

1. Press the red button of the socket to release the seat belt.
The seat belt reels itself in and gets retracted to the left side.

IMPORTANT :

- **When removing the seat belt, store the belt straight.**
If you store the belt without straightening it, the seat belt locking mechanism may not work properly.

STARTING THE MACHINE

WARNING

To avoid personal injury or death:

- Read and understand this manual before operating the machine.
- Do not allow any person other than the operator to ride on the machine.
- When operating, keep hands and body inside of the ROPS or OPG (top guard level I).
- Do not touch the control levers and the pedals from outside the CAB while the engine is running.

1. Pilot control lock lever

NOTE :

- If the pilot control lock lever is in the UNLOCK position, the engine will not start.

Do not attempt to start the machine with the pilot control lock lever in the UNLOCK position. If the attempt is made, the following message appears on the display.

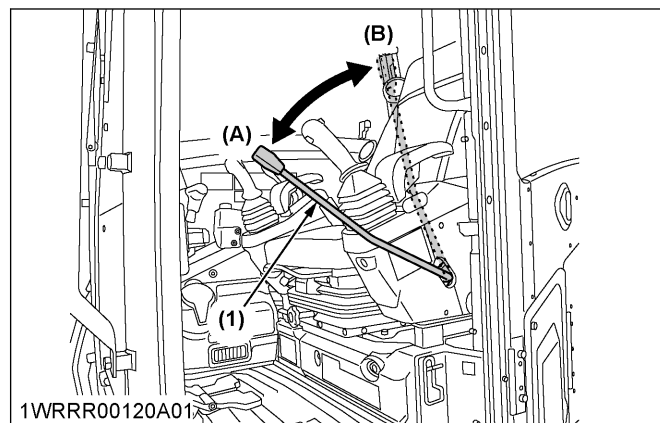
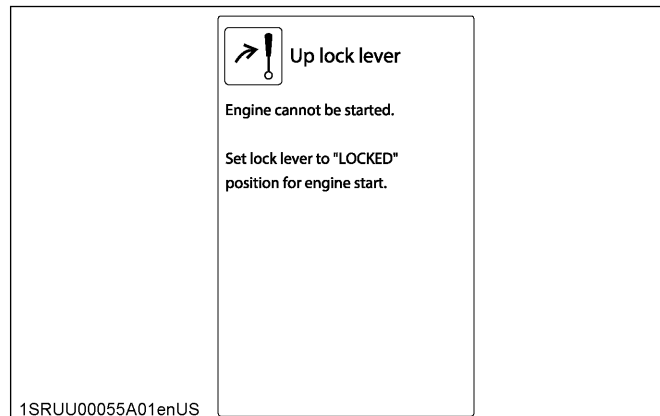

- (1) Pilot control lock lever
- (A) UNLOCK
- (B) LOCK

IMPORTANT :

- Always pull the pilot control lock lever up to the LOCK position when you stop the engine or leave the operating structure.

DRIVING

WARNING

To avoid personal injury or death:

- Before starting the engine, make sure that no one is near the machine.
- Before operating the machine, check the track direction (front idler and dozer blade to the front of the machine).

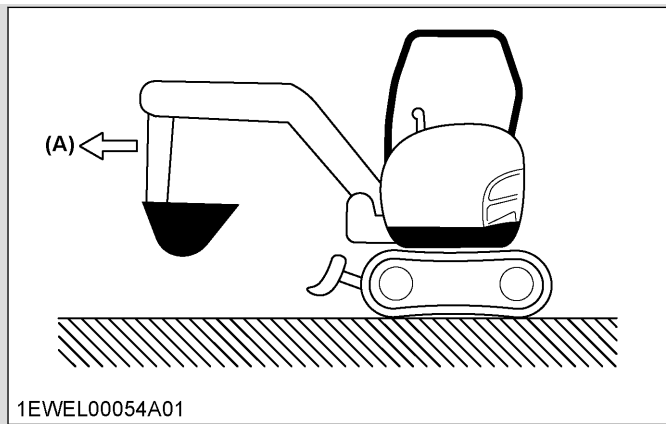

(A) Front of the machine

- **Be extra cautious when traveling across a slope or working sideways on a slope:**

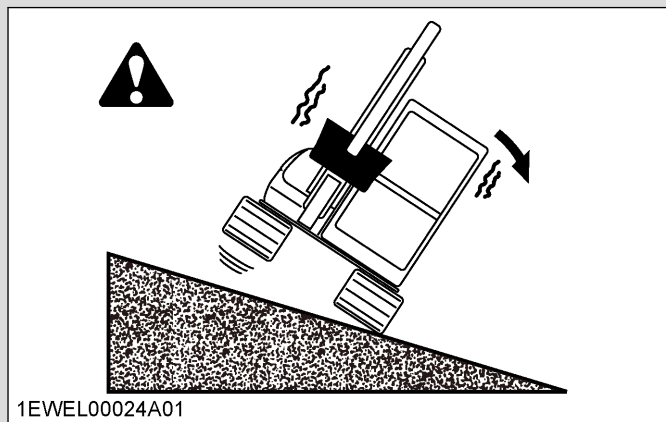

- **The recommended technique for working on a slope:**

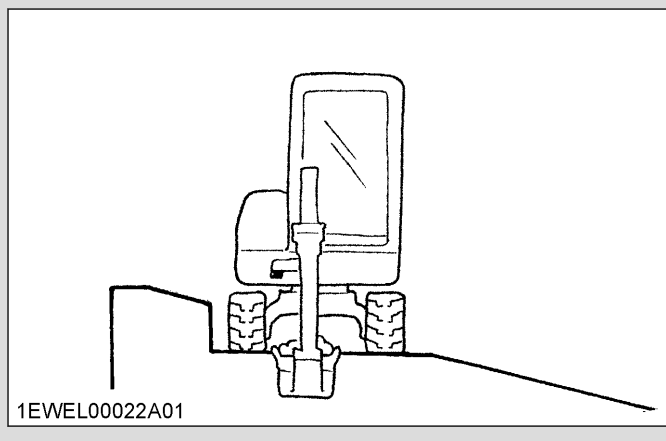

1. Adjust the engine speed from idling to an intermediate speed.
2. Unlock the pilot control lock lever, pull in the bucket and hold the bucket about 20 cm to 40 cm (8 in. to 16 in.) above the ground.

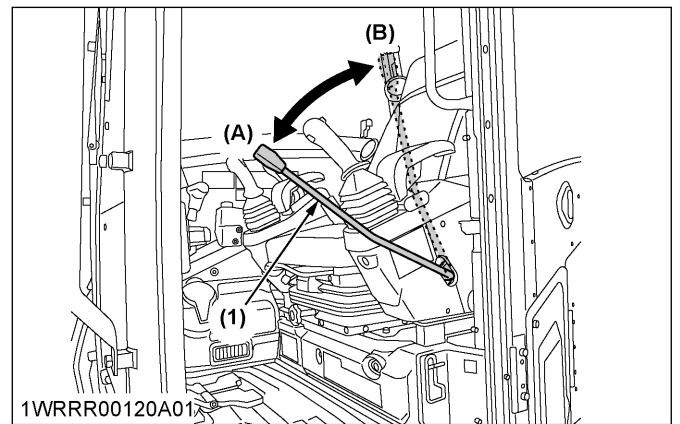

(1) Pilot control lock lever

- (A) UNLOCK
- (B) LOCK

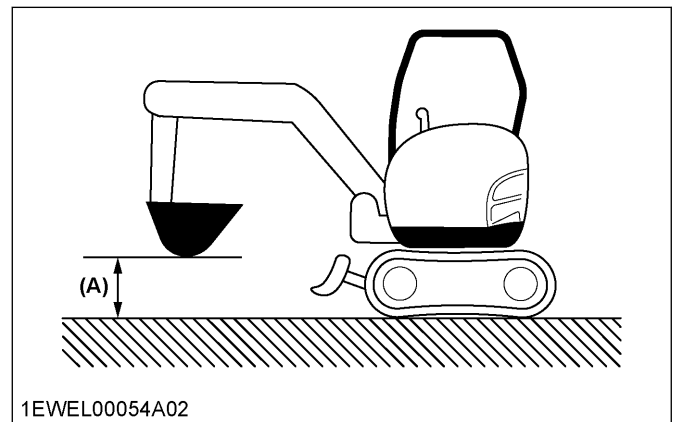

(A) 20 cm to 40 cm (8 in. to 16 in.)

3. Activate the dozer control lever to raise the dozer.

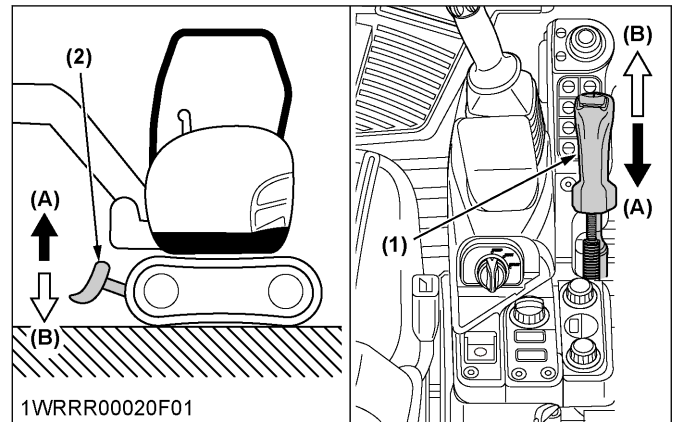

(1) Dozer control lever

- (A) Raise
- (B) Lower

1. Drive levers (right, left)

NOTE :

- **When driving the machine, keep the dozer blade in the front. To move the machine forward, move the drive levers to (A). To move in reverse, move the drive levers to (B) with dozer blade in front.**

If the dozer blade is behind the operator station, then the controls are reversed. Moving the machine forward will require (B) and moving the machine backward will require (A), but this is not recommended.

Pushing the drive levers forward moves the machine forward and vice-versa. The dozer is located at the front of the machine. The drive sprocket is located at the rear of the machine.

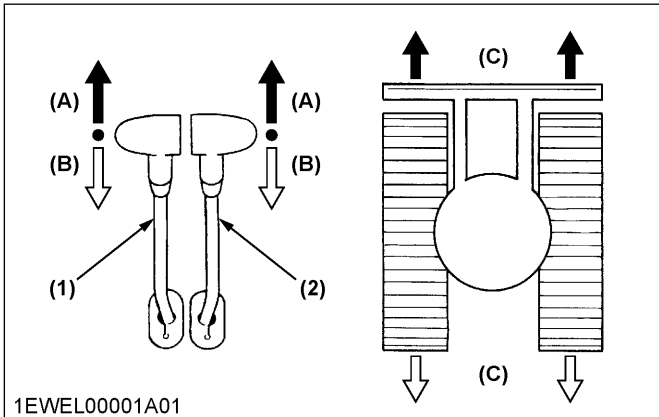

1EWEL00001A01

- (1) Drive lever (left)
- (2) Drive lever (right)
- (A) Forward
- (B) Backward
- (C) Straight

URNS

WARNING

To avoid personal injury or death:

- Do not change direction on steep slopes, or the machine could roll over.
- Before changing direction, be aware of people and obstacles in the work area.

1. Pivot turn

NOTE :

- Movement, as illustrated, is done with the dozer blade in front of the operator.

Changing direction while traveling

- While traveling forward, bring the left drive lever into the "NEUTRAL" position and the machine will turn in the direction of the arrow. See the following illustration.

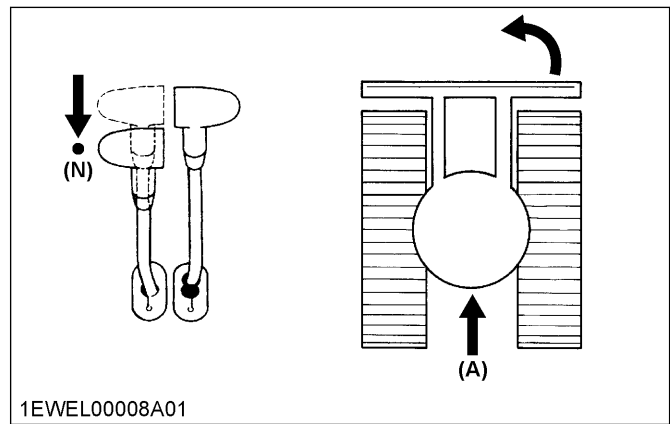

1EWEL00008A01

- (A) Traveling forward
- (N) Neutral position

- While traveling backward, bring the left drive lever into the "NEUTRAL" position and the machine will turn in the direction of the arrow. See the following illustration.

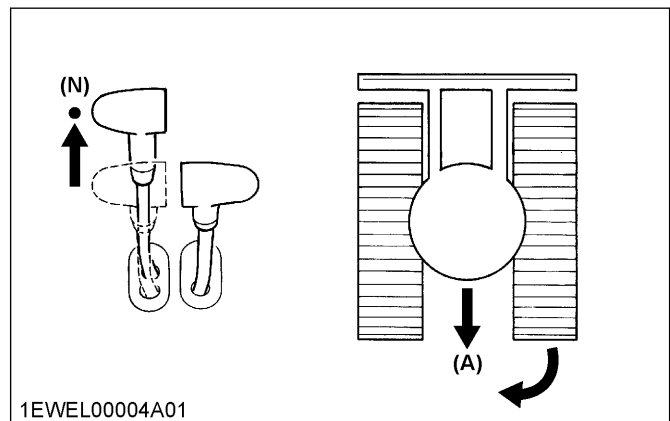

1EWEL00004A01

- (A) Traveling backward
- (N) Neutral position

Changing direction when stationary

- Push the left drive lever forward and the machine will turn in the direction of the arrow. See the following illustration.

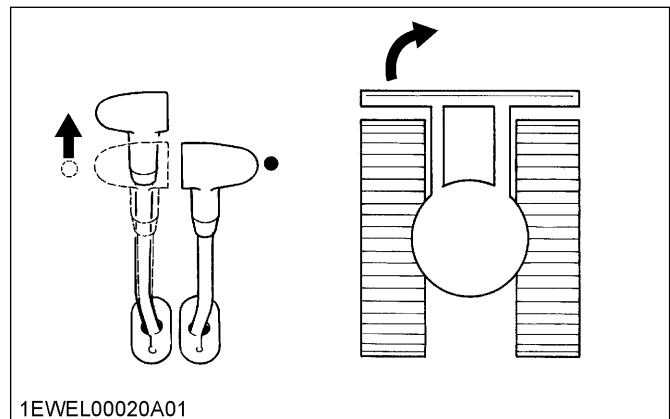

1EWEL00020A01

- Pull the left drive lever backward and the machine will turn in the direction of the arrow. See the following illustration.

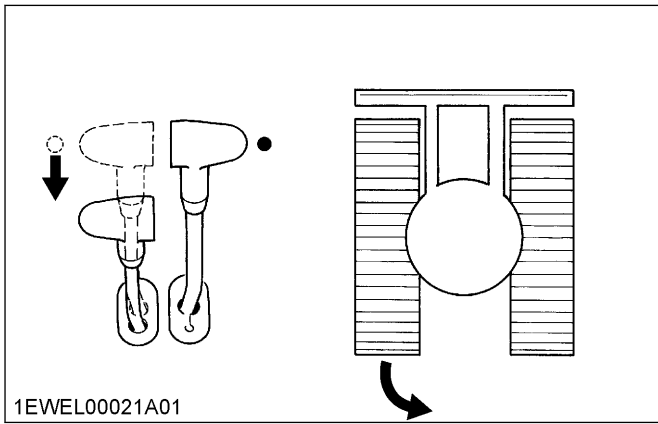

2. Spin turn

When both drive levers are activated in the opposite directions, both tracks will rotate with the same speed but in opposite directions. The center of rotation is the center of the machine.

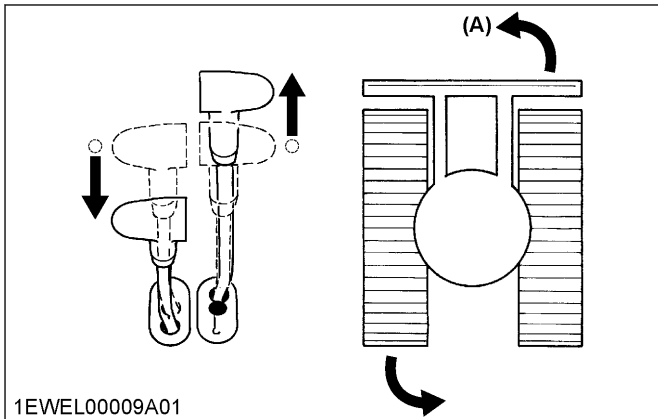

(A) Left spin turn

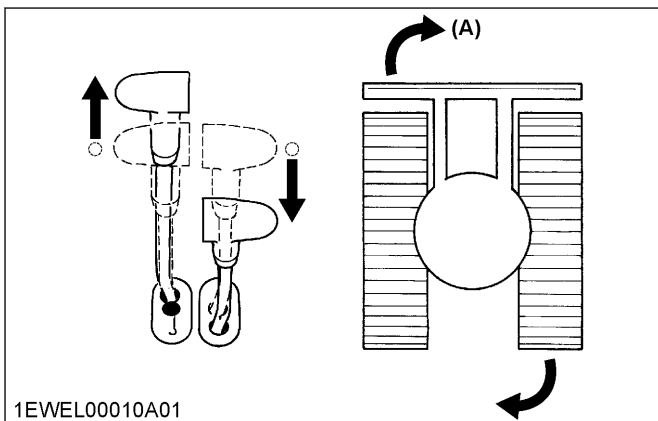

(A) Right spin turn

UP AND DOWNHILL DRIVING

⚠ WARNING
To avoid personal injury or death:

- When traveling up or down a slope, be extra cautious and observe the following instructions.

While traveling uphill, keep the lower edge of the bucket approximately 20 cm to 40 cm (8 in. to 16 in.) above the ground. Although the excavator will not slip easily because of the tracks, it is safer to let the bucket slide over the ground while traveling downhill. Always choose slow speed for uphill and downhill traveling.

Uphill traveling

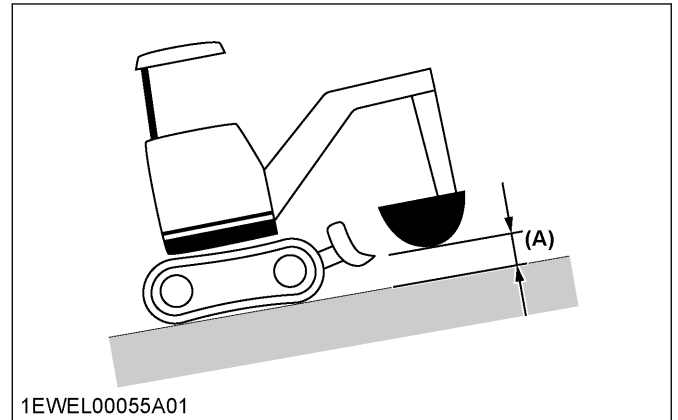

(A) 20 cm to 40 cm (8 in. to 16 in.)

Downhill traveling

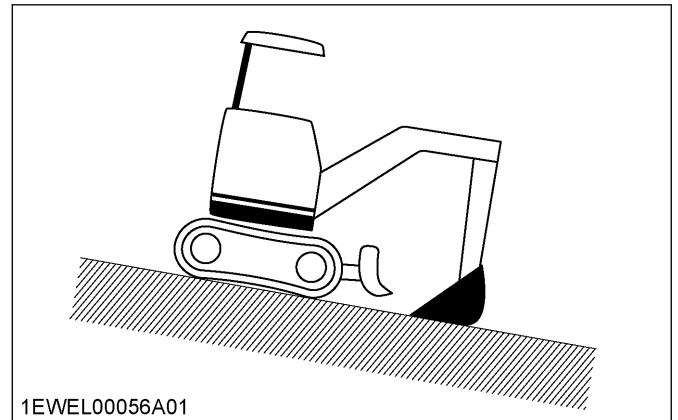

PARKING ON A SLOPE

⚠ WARNING

To avoid personal injury or death:

- When the machine is parked or left unattended on a slope, put the bucket on the ground and place all control levers in their "NEUTRAL" positions, then brace the tracks with chocks.

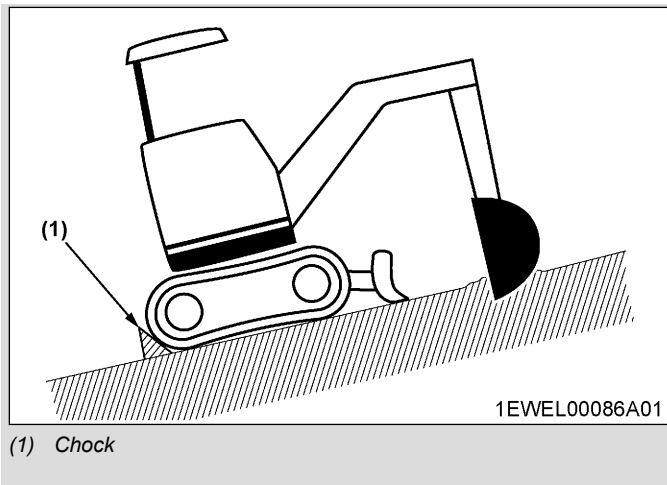

(1) Chock

OPERATING THE DOZER

- Pulling the control lever back raises the dozer.
- Pushing the control lever forward lowers the dozer.
- Pushing the control lever further forward (into the locked position) floats the dozer.

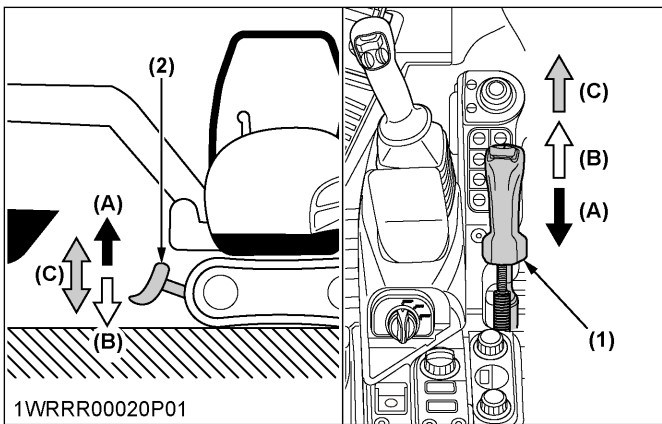

(1) Dozer control lever (A) Raise
 (2) Dozer (B) Lower
 (C) Float (locked position)

- While performing earthmoving work, control both drive levers with the left hand and the dozer control lever with the right hand.

TWO PATTERN SELECTION SYSTEM (TPSS)

- Study control lever pattern A and pattern B and then choose the one which feels most familiar.
- Position the pattern selector lever (located on the right side of operator's seat) in either the lower position (pattern A) or the upper position (pattern B).
- Engage the lever lock to prevent accidental pattern change.
- Familiarize yourself with the pattern selected by operating slowly.

1. Pattern change

1. Pull the pattern selector lever to disengage the lever lock and position the pattern selector lever to the desired position.
2. Engage the lever lock.

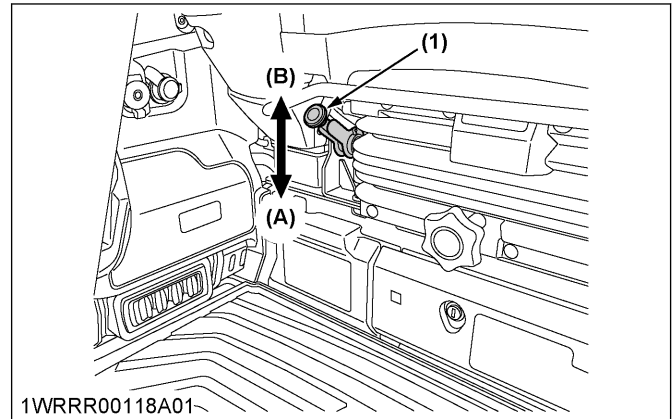

(1) Pattern selector lever (A) Pattern A
 (two pattern selection system: TPSS) (B) Pattern B

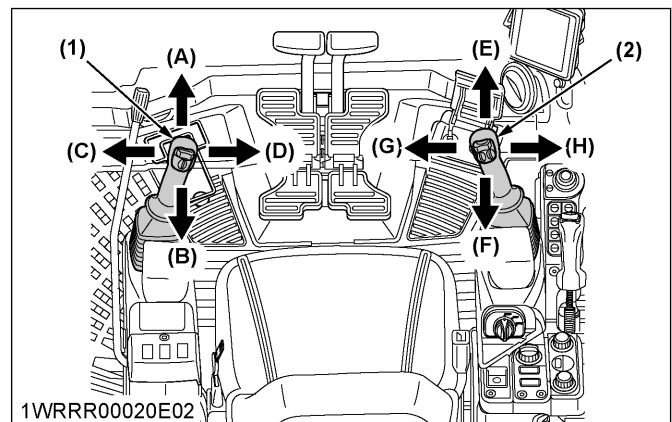

(1) Attachment control lever (left)
 (2) Attachment control lever (right)

	Lever position	Pattern A	Pattern B
Attachment control lever (left)	(A)	Boom down	Arm up
	(B)	Boom up	Arm crowd
	(C)	Swivel left	Swivel left
	(D)	Swivel right	Swivel right
Attachment control lever (right)	(E)	Arm up	Boom down
	(F)	Arm crowd	Boom up
	(G)	Bucket crowd	Bucket crowd
	(H)	Bucket dump	Bucket dump

OPERATION OF THE BOOM

To raise the boom, pull the attachment control lever backward.

The boom is equipped with a cushion cylinder which helps prevent excavated material in the bucket from falling out. At low hydraulic oil temperature, for instance after starting the engine in cold weather, the cushioning function will be affected for a short period of time (approximately 3 to 5 seconds). This condition results from the viscosity of the hydraulic oil and is not a sign of malfunction.

The cushion cylinder will operate normally as the oil warms up.

To lower the boom, push the attachment control lever forward.

Pattern A

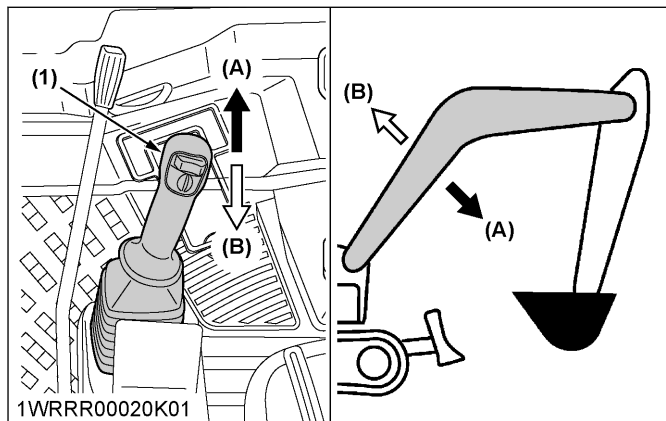

(1) Attachment control lever (left) (A) Boom down (B) Boom up

Pattern B

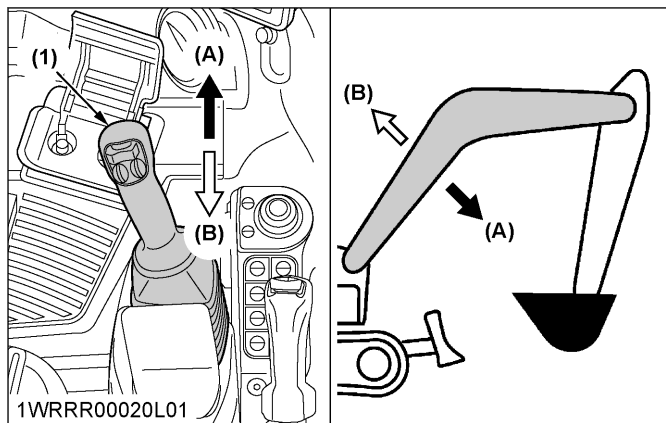

(1) Attachment control lever (right) (A) Boom down (B) Boom up

IMPORTANT :

- When lowering the boom, make sure that it does not hit the dozer and that the bucket teeth do not touch the dozer.

OPERATION OF THE ARM

- Pulling the attachment control lever back pulls the arm in.
- Pushing the attachment control lever forward moves the arm out.

Pattern A

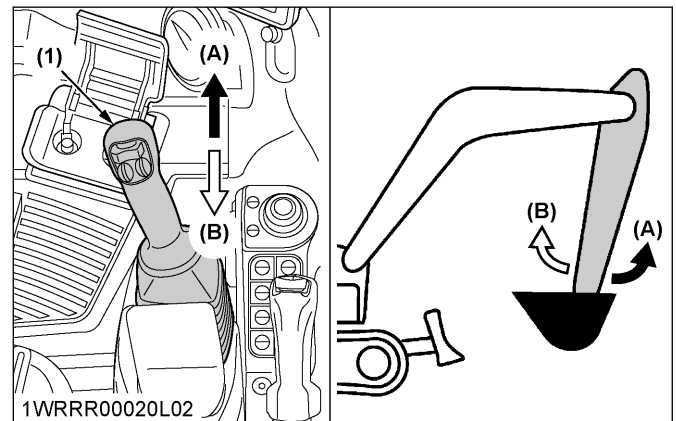

(1) Attachment control lever (right) (A) Arm out (up) (B) Arm in (crowd)

Pattern B

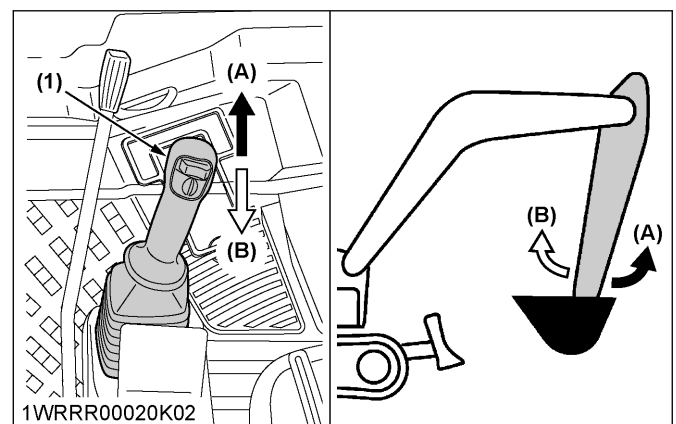

(1) Attachment control lever (left) (A) Arm out (up) (B) Arm in (crowd)

NOTE :

- When pulling in the arm, the movement may stop for a short moment when the arm is in its vertical position. This is caused by the combined load of the arm and bucket moving the cylinder piston away from the hydraulic flow causing a delay in the cylinder action, until the flow catches up with cylinder piston. This is a characteristic of the hydraulic system and is not a sign of a malfunction.

OPERATION OF THE BUCKET

- To dig using the bucket, move the right attachment control lever left from the "NEUTRAL" position.
- Moving the control lever right moves the bucket outwards and empties its contents.

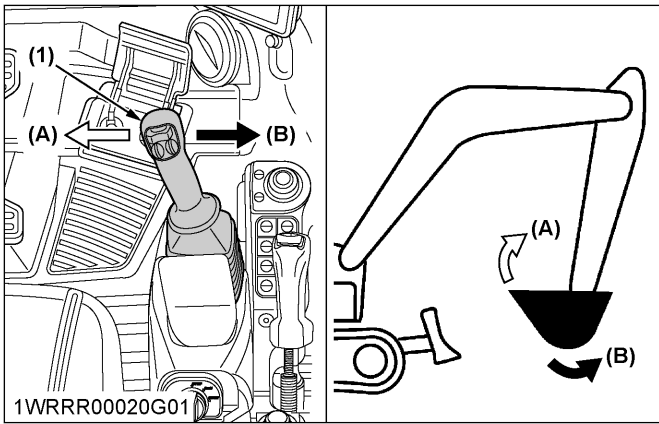

(1) Attachment control lever (right) (A) Bucket crowd (B) Bucket dump

SWIVEL AND BOOM SWING OPERATION

WARNING

To avoid personal injury or death:

- When working in groups, always let others know what you are going to do before you do it.
- Keep others away from the machine working area.
- Lock the boom swing pedal when the boom swing function is not used.

1. Swivel operation

IMPORTANT :

- Do not operate the left attachment control lever abruptly from right to left (or vice versa). This causes high impact loading on the swivel gear and the swivel motor, shortening the life of the machine.
- Move the control lever to the left and the upper structure will turn to the left.
- Move the control lever to the right and the upper structure will turn to the right.

Swivel

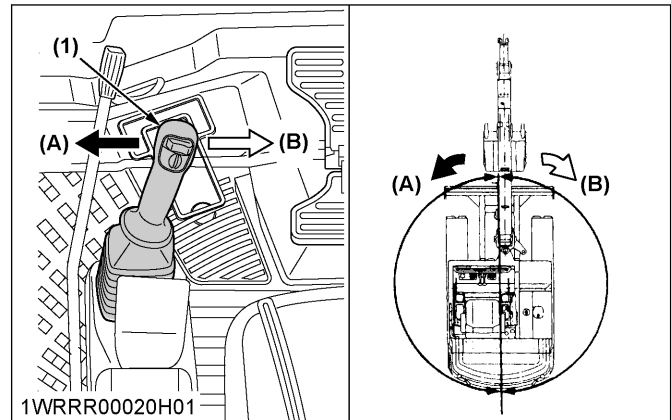

(1) Attachment control lever (left) (A) Swivel left (B) Swivel right

2. Boom swing operation

1. Flip the pedal lock up to unlock the pedal.
2. Operate the boom swing as follows:
 - Step on the left side of the pedal to swing the boom to the left.
 - Step on the right side of the pedal to swing the boom to the right.

Boom swing

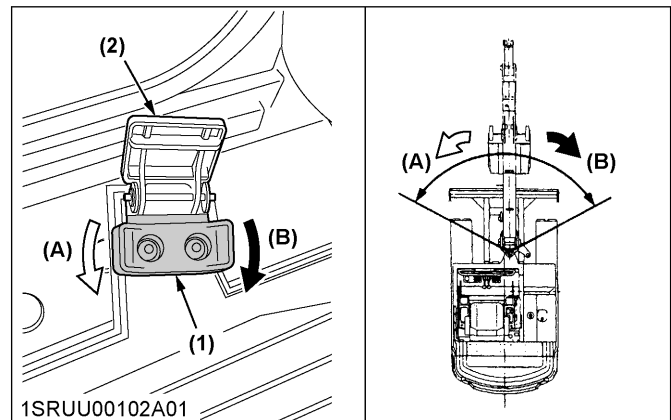

(1) Boom swing pedal (2) Pedal lock (A) Swing left (B) Swing right

AUXILIARY PORT OPERATION

There are two different models: the AUX 1 model and the AUX 1 and AUX 2 model.

[AUX 1 model]

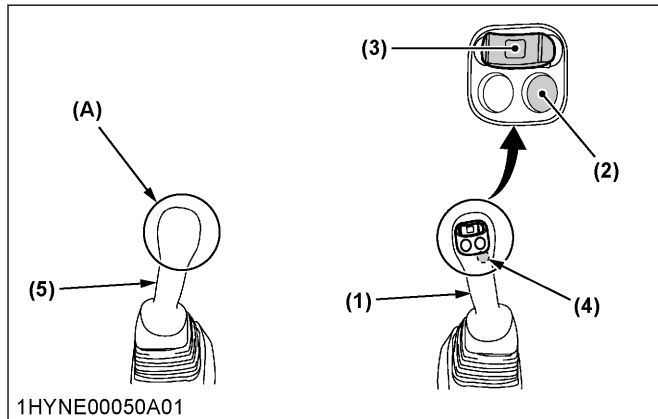

- (1) Attachment control lever (right)
- (2) AUX port enable switch
- (3) AUX 1 port knob (right)
- (4) One-way hold switch (right)
- (5) Attachment control lever (left)
- (A) No switches or knobs on the lever

[AUX 1 and AUX 2 model]

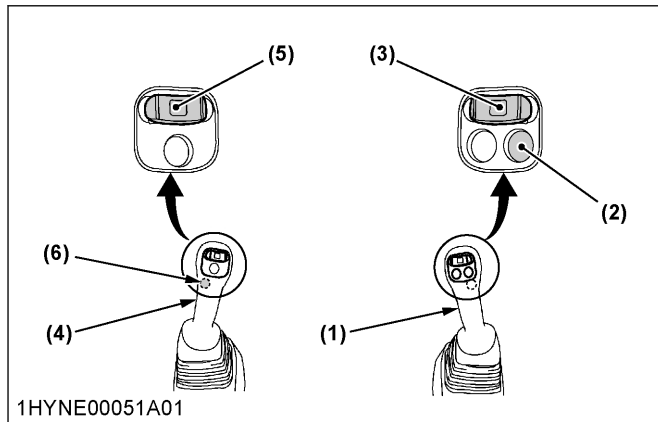

- (1) Attachment control lever (right)
- (2) AUX port enable switch
- (3) AUX 2 port knob (right)
- (4) Attachment control lever (left)
- (5) AUX 1 port knob (left)
- (6) One-way hold switch (left)

The AUX port enable switch is used to operate hydraulic attachments such as hammers.

1. Selecting operation modes

The AUX port has been factory-set to 3 operation modes in the case of the AUX 1 model, and 2 modes in the case of the AUX 1 and AUX 2 model. You can select one of them. Up to 5 operation modes can be preset.

(See Setting the maximum flow volume on page 97.)

1. Press the menu switch to make the menu bar appear on the display.
2. Rotate the jog dial to the right to select “AUX setting”, and press the jog dial.

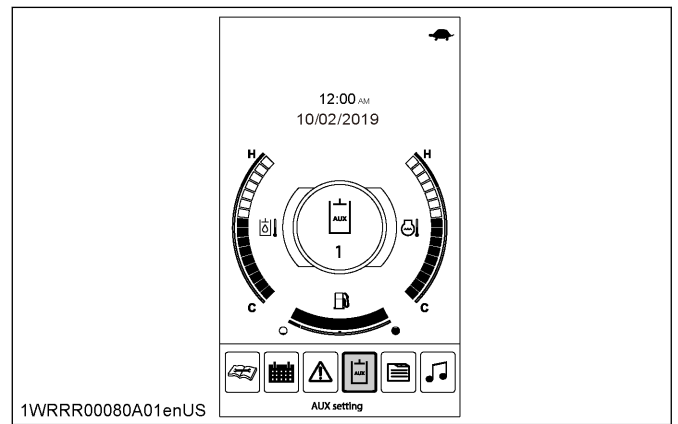

3. Rotate the jog dial to the right to select “Mode select”, and press the jog dial.

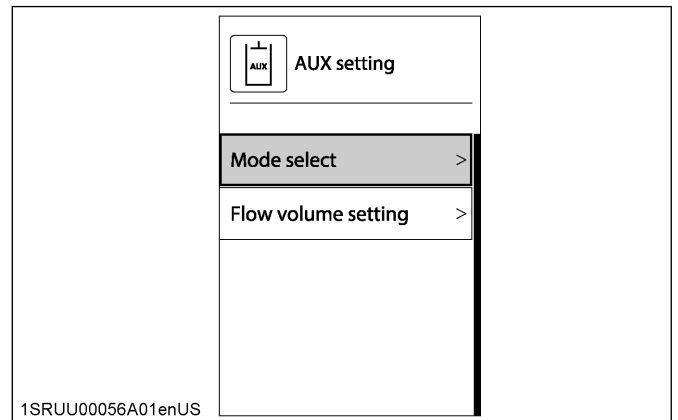

4. Rotate the jog dial to the right to select the desired mode, and press the jog dial to confirm the selection.
The following illustrations and tables show the factory default settings for the AUX 1 model and the AUX 1 and AUX 2 model respectively.

[AUX 1 model]

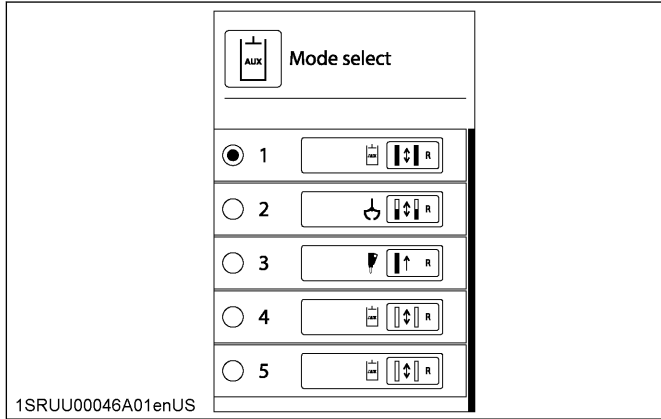

1SRUU00046A01enUS

Mode	Icon	AUX 1 port flow volume
		One-way or two-way circuit selection valve
1	AUX (standard)	Maximum flow volume
		two-way
2	Grapple	Limited flow volume
		two-way
3	Breaker	One-way flow (Send oil to port 2 only)
		one-way
4	AUX (standard)	No activation
		two-way
5	AUX (standard)	No activation
		two-way

[AUX 1 and AUX 2 model]

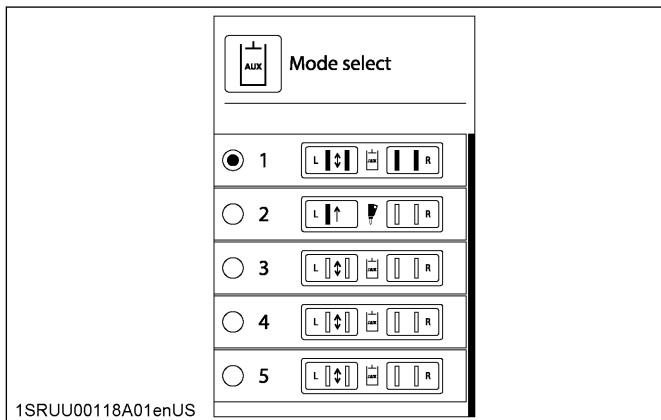

1SRUU00118A01enUS

Mode	AUX 1 port flow volume	Icon	AUX 2 port flow volume
	One-way or two-way circuit selection valve		
1	Maximum flow volume	AUX (standard)	Maximum flow volume
	two-way		
2	One-way flow (Send oil to port 2 only)	Breaker	No activation
	one-way		
3	No activation	AUX (standard)	No activation
	two-way		
4	No activation	AUX (standard)	No activation
	two-way		
5	No activation	AUX (standard)	No activation
	two-way		

NOTE :

- When turning the starter switch to the [RUN] position, the operation mode will return to the last operation mode used.

2. Operating the AUX port

- Turn the starter switch to the [RUN] position. Let the engine warm up after start-up for approximately 10 minutes under no load conditions.

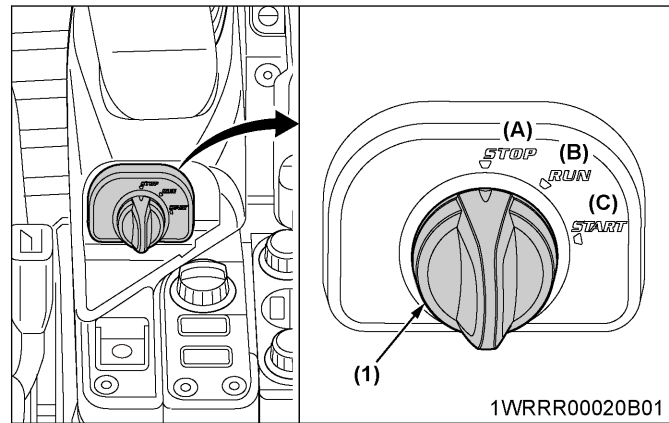

(1) Starter switch

- (A) STOP
- (B) RUN
- (C) START

1WRRR00020B01

2. Lower the pilot control lock lever to the UNLOCK position.

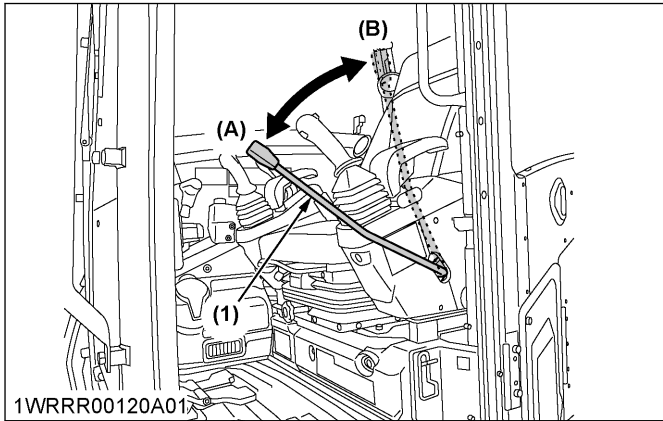

(1) Pilot control lock lever (A) UNLOCK (B) LOCK

3. Push the AUX port enable switch.

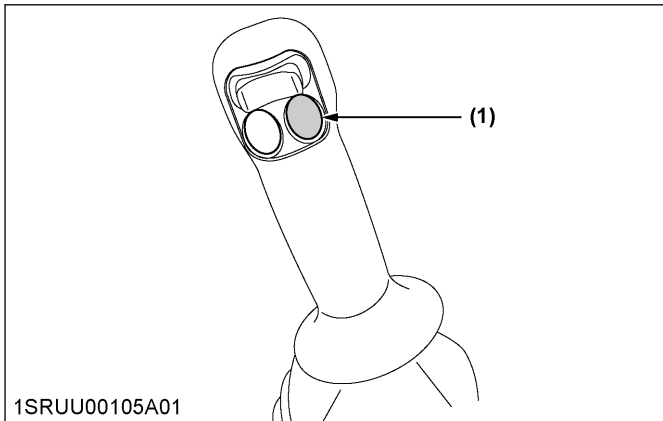

(1) AUX port enable switch

NOTE :

- If the pilot control lock lever is at the LOCK position, the following message appears on-screen. Push down this lever to the UNLOCK position and then press the AUX port enable switch.

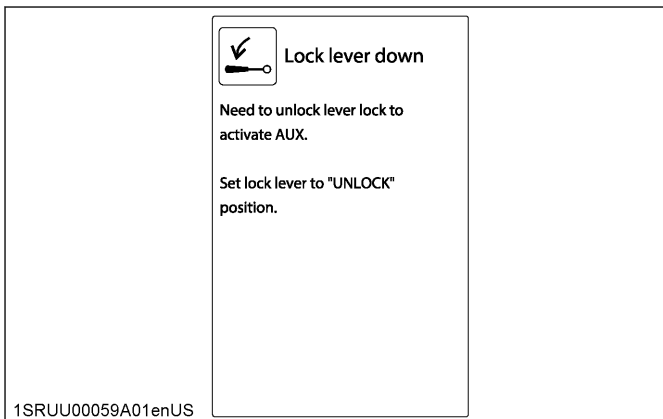

4. Operate the AUX port knob as follows:

[AUX 1 model]

- Move the AUX port knob of the attachment control lever (right) to the right to send oil to the AUX port 1.
- Move the AUX port knob of the attachment control lever (right) to the left to send oil to the AUX port 2.

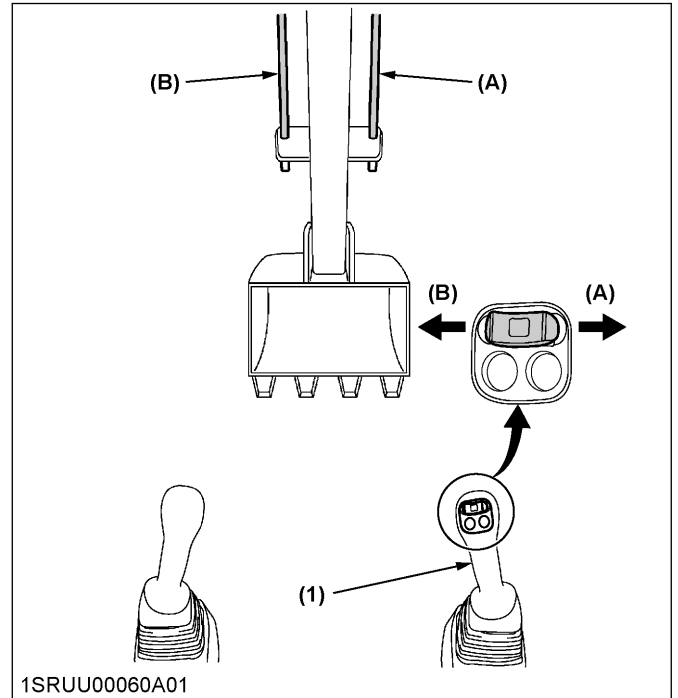

(1) Attachment control lever (right) (A) AUX port 1 (B) AUX port 2

[AUX 1 and AUX 2 model]

- Move the AUX port knob of the attachment control lever (left) to the right to send oil to the AUX port 1.
- Move the AUX port knob of the attachment control lever (left) to the left to send oil to the AUX port 2.
- Move the AUX port knob of the attachment control lever (right) to the right to send oil to the AUX port 3.
- Move the AUX port knob of the attachment control lever (right) to the left to send oil to the AUX port 4.

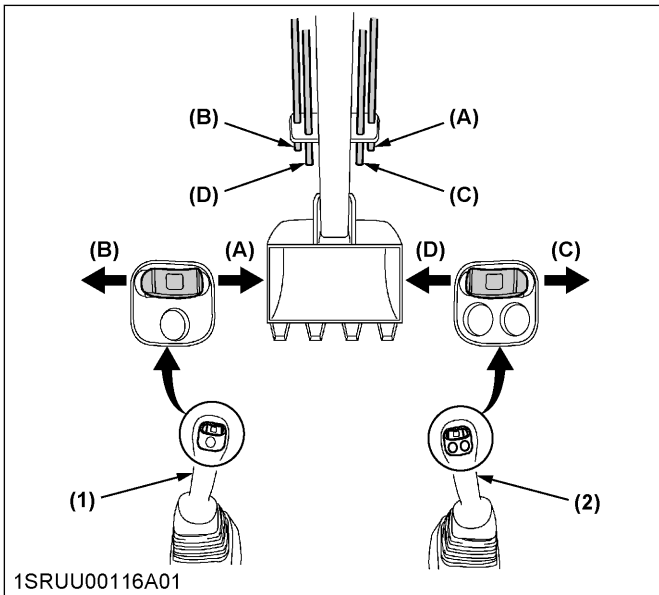

- (1) Attachment control lever (Left)
- (2) Attachment control lever (right)
- (A) AUX port 1
- (B) AUX port 2
- (C) AUX port 3
- (D) AUX port 4

IMPORTANT :

- **Proportional control of the AUX port knob allows for slow-to-fast movement of the attachment.**
For example, if you move the AUX port knob halfway, the attachment will move at approximately one-half speed.

NOTE :

- Only when the auxiliary port function is enabled, the rocker switch allows the oil to flow towards the auxiliary port. If this function is disabled, no oil flows towards the auxiliary port, and the message "Enable AUX port" appears on-screen.
To enable this function, press the AUX port enable switch.

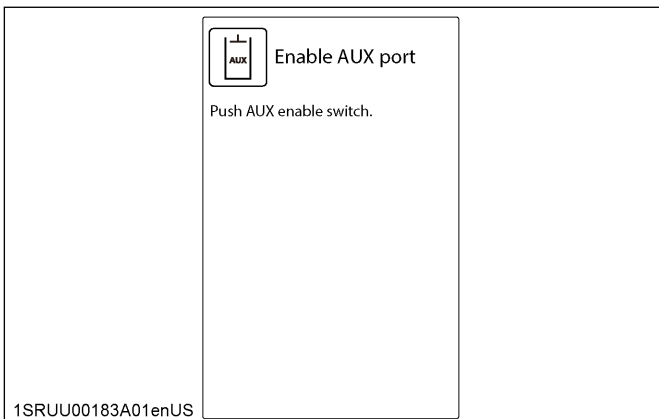

2.1 One-way hold

! DANGER

To avoid serious injury or death:

- Before using the one-way hold switch, make sure that nobody is in the working area. The attachment can move in an uncontrolled and sudden manner, which poses a danger to life in the working area.
- Before using the one-way hold switch, check that the accessory is suitable for use with continuous oil flows. When using accessories that are not suitable for continuous oil flows, using the one-way hold switch poses a danger to life.
- Always adapt the flow volume of the auxiliary port to the accessory. The auxiliary port cannot be operated proportionally with the one-way hold switch. The flow volume is adjusted to the highest level in the factory.

[AUX 1 model]

Press the one-way hold switch of the attachment control lever (right), and the oil continues to flow through the AUX port 2. Press this switch again or move the AUX port knob, and the oil flow is interrupted.

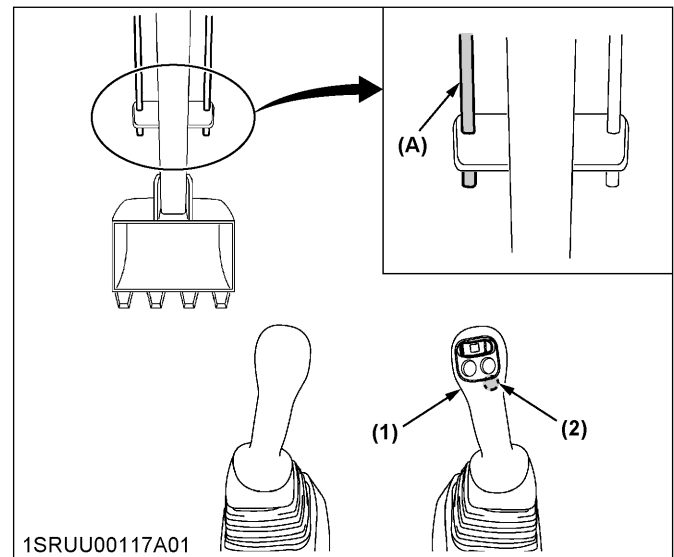

- (1) Attachment control lever (right)
- (2) One-way hold switch (right)
- (A) AUX port 2

[AUX 1 and AUX 2 model]

Press the one way hold switch of the left attachment control lever, and the oil continues to flow through the AUX port 2. Press this switch again or move the AUX port knob, and the oil flow is interrupted.

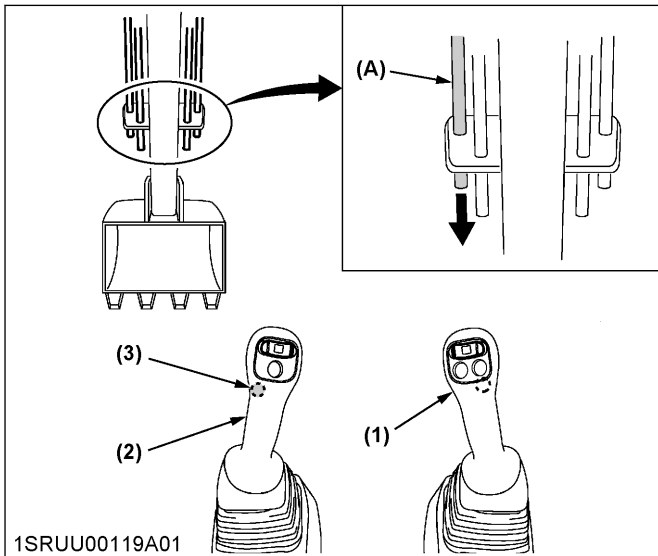

1SRUU00119A01

- (1) Attachment control lever (right)
- (2) Attachment control lever (left)
- (3) One-way hold switch (left)
- (A) AUX port 2

NOTE :

- Even if the one-way hold switch of the attachment control lever (right) is pressed, no function is assigned. In such a case, the following message appears on-screen.

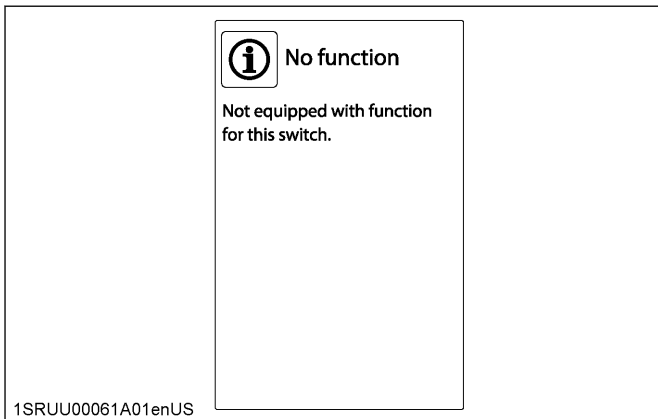

1SRUU00061A01enUS

3. Maximum flow volume

The AUX port has been factory-set to 3 operation modes in the case of the AUX 1 model, and 2 modes in the case of the AUX 1 and AUX 2 model. Additional modes can also be preset.

3.1 Setting the maximum flow volume

IMPORTANT :

- When the AUX port is not used for a long period of time, dirt particles can settle in the lower part of the AUX port lines. When the plugs on the AUX port lines are removed to connect

attachments, drain approximately 100 cc (3.4 oz) of oil before making connections.

NOTE :

- If the same implement is attached to a different machine, the working speed may differ, even when using identical flow rate settings. For each machine, it is important to individually adjust the flow rate settings. Upon changing the implement, you need to determine and adjust the optimum flow rates for the new implement.
- The flow at the AUX port is not constant when using a different function or if a relief valve is responding.
- It is recommended to adjust this setting during the operation of the implement.

1. With the starter switch at the [RUN] position, press the menu switch.
2. Rotate the jog dial to the right, select "AUX setting", and press the jog dial.

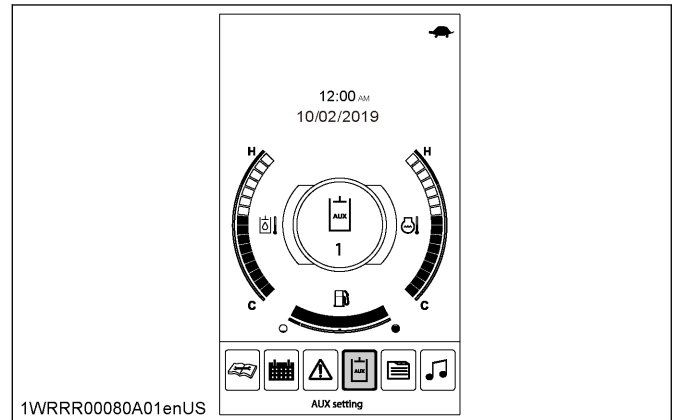

1WRRR00080A01enUS

3. Rotate the jog dial to the right to select "Flow volume setting", and press the jog dial.

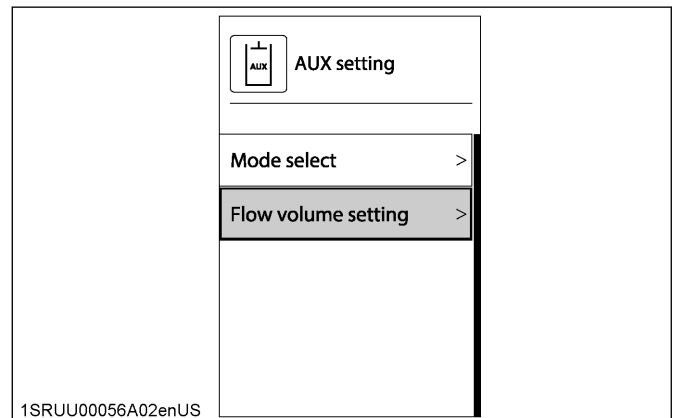

1SRUU00056A02enUS

4. Rotate the jog dial to the right to select the desired mode, and press the jog dial.

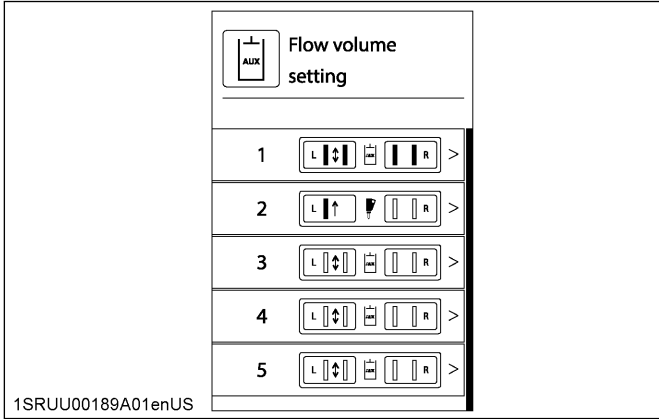



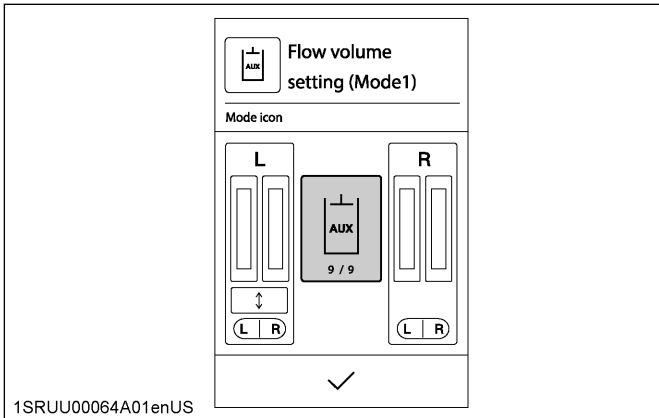



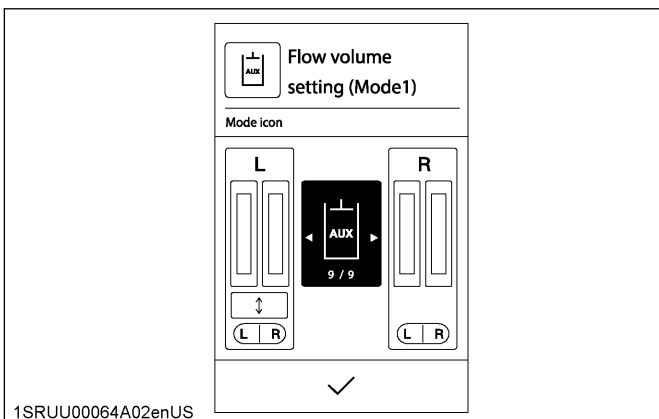

5. Set the icons as follows:
 a. Rotate jog dial to the right or left until the icon is selected, and press Jog dial.

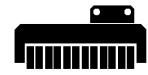

- b. Rotate jog dial to the right or left until the desired icon is selected, and press jog dial to confirm.



Types of AUX icons

(1) 	(6) 
(2) 	(7) 
(3) 	(8) 
(4) 	(9) 
(5) 	

1SRUU00137A01

- | | |
|-----------------|--------------------|
| (1) Tilt bucket | (6) Rotary grapple |
| (2) Breaker | (7) Brush cutter |
| (3) Clamshell | (8) Thumb grapple |
| (4) Auger | (9) AUX (standard) |
| (5) Grapple | |

NOTE :

- There is no relationship between the icons and the flow control settings. Select icons to suit the images of the attachments to be connected.

6. Set the maximum flow volume for each AUX port as follows:
 - a. Rotate jog dial to the right or left until the desired bar graph is selected, and press the jog dial.

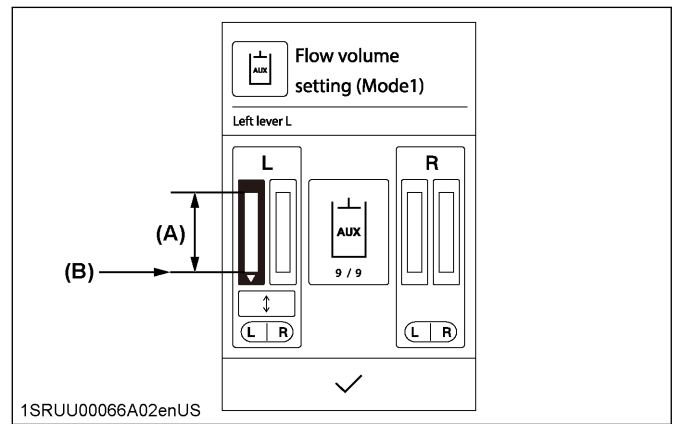
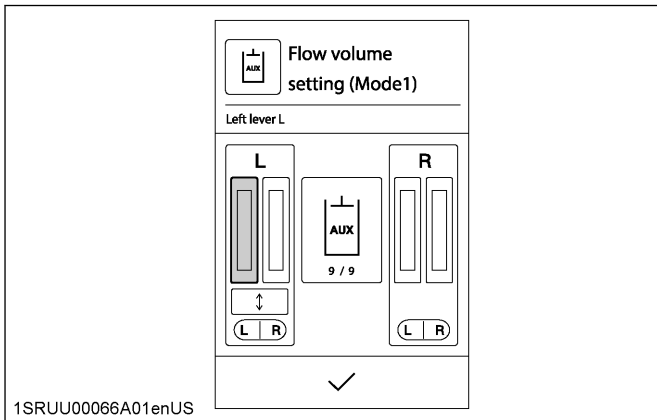

- (A) MAX. flow volume
- (B) Output interrupted

AUX port maximum flow volume

	AUX 2 port	AUX 1 port
Maximum flow volume (theoretical) L (U.S.gals) /min	37 (9.8)	65 (17)
Maximum pressure MPa (kgf/cm ² / psi)	17.2 (175 / 2500)	

- c. Repeat the process for each AUX port.

NOTE :

- Some attachments might not be activated even when the bar level is still above the lowest position. Even when the bars of ports 1 and 2 (or of ports 3 and 4) are at the same level, the same speed might not be achieved. This does not indicate a machine problem. Readjust the bar to the optimum level according to your attachment manual.
- Suppose that the same attachment is mounted on another machine. Even if the same flow control setting is made, the same speed cannot be achieved. Make an optimum setting on each machine.

[AUX 1 and AUX 2 model]

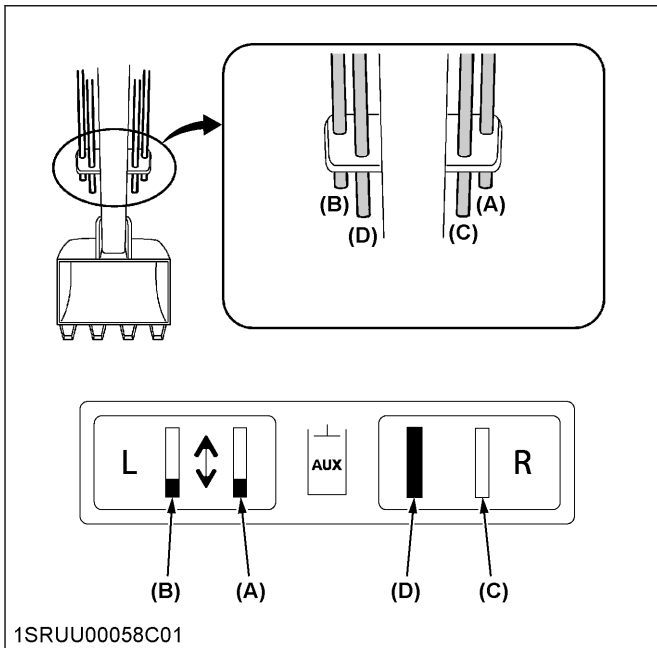

- (A) AUX port 1
- (B) AUX port 2
- (C) AUX port 3
- (D) AUX port 4

- b. Rotate the jog dial to the right or left to set the bar graph to the desired level, and press the jog dial to confirm the selection.

7. Set the one-way or two-way circuit selection valve as follows:
 - a. Rotate jog dial to the right or left to select the one-way or two-way circuit selection valve, and press the jog dial.

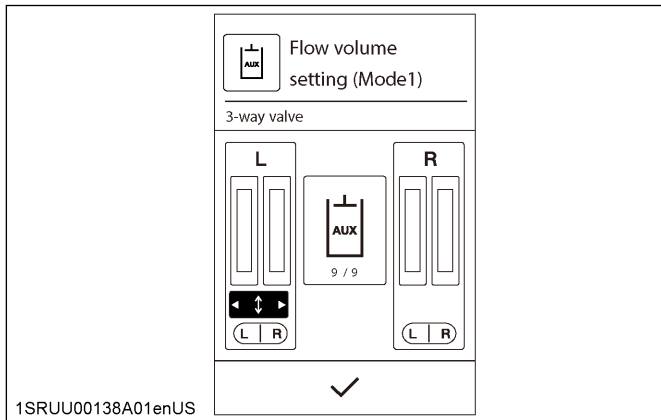

- b. Rotate jog dial to the right or left to select the desired setting, and press the jog dial.

Valve	Two-way	One-way
Icon	↕	↑

8. Rotate jog dial to the right to select the “✓” and press the jog dial to save the input, or press the return switch to cancel.

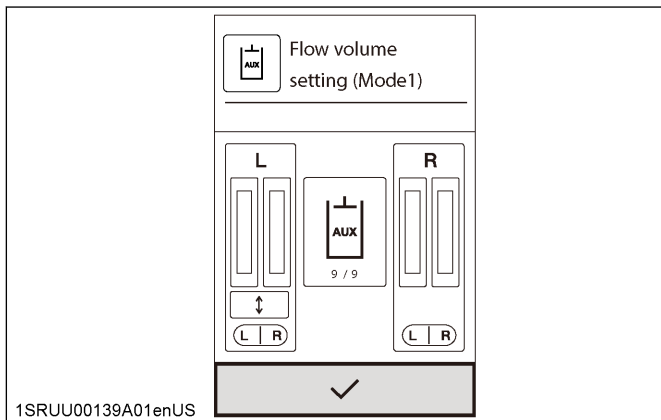

RELEASING PRESSURE TRAPPED IN THE HYDRAULIC SYSTEM

WARNING

To avoid personal injury or death:

- Relieve residual hydraulic pressure immediately after the engine has stopped.

1. Lower the attachments and the blade down to the ground.

2. Turn the starter switch to the **[STOP]** position and shut off the engine.
3. After stopping the engine, turn the starter switch to the **[RUN]** position.
4. Set the pilot control lock lever to the UNLOCK position.

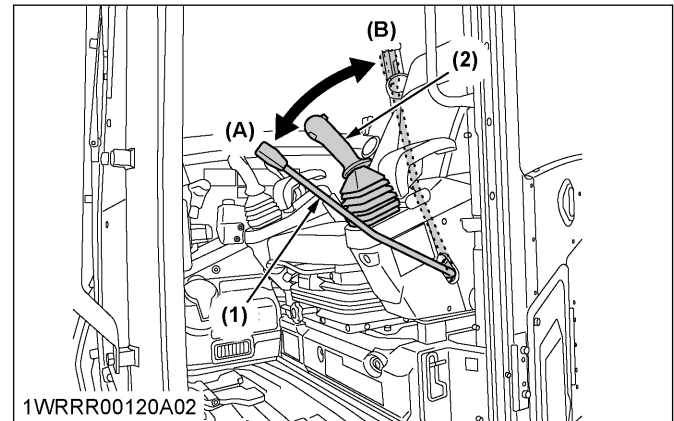

- (1) Pilot control lock lever (A) UNLOCK
 (2) Attachment control lever (left) (B) LOCK

5. Move the operating lever to release pressure from the hydraulic system.

1. Releasing pressure trapped in the AUX port

1. Release the pressure trapped in the hydraulic system.
 (See RELEASING PRESSURE TRAPPED IN THE HYDRAULIC SYSTEM on page 100.)
2. Press the AUX port enable switch.

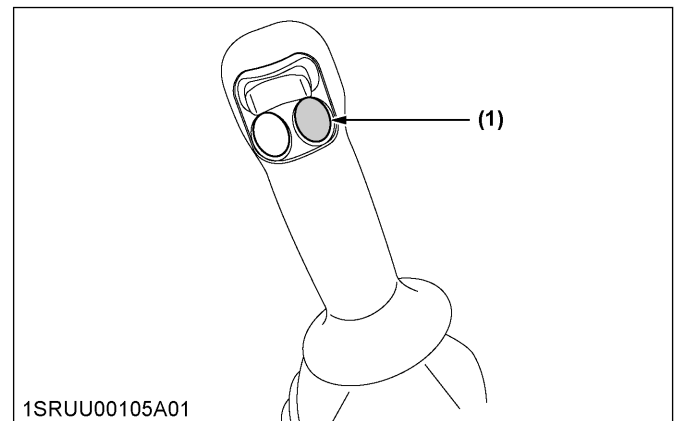

- (1) AUX port enable switch

- Make sure that the flow volume in all the AUX ports is not minimized.
If the pressure is removed after minimizing the flow volume in the AUX port, the pressure will not be released completely and the hose coupler may be unable to connect and disconnect.

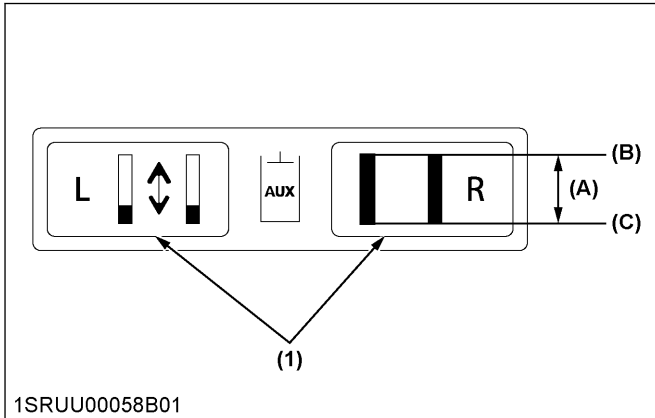

- (1) Flow volume in AUX port dis- (A) Flow volume in AUX port
play (B) Maximum
(C) Minimum

- Move the AUX port knob mounted to the operating lever to the right to release pressure in the AUX port.

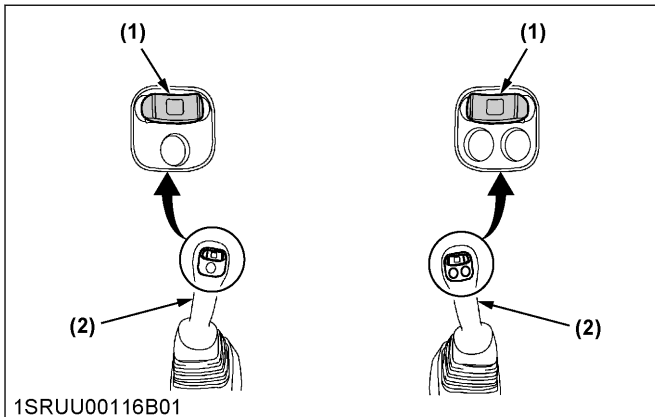

- (1) AUX port knob
(2) Attachment control lever

NOTE :

- There are two types of machine, one has the AUX port knobs mounted to the right and left operating levers, the other has the AUX port knob mounted to one operating lever. Make choice according to the type of machine.

ANGLE BLADE OPERATION [ANGLE BLADE TYPE]



WARNING

To avoid personal injury or death:

- Never jack up or lift the machine with the angle blade placed at an angle. Stability of the machine is affected with the blade at an angle, therefore keep at the neutral position. Before starting the job, position and keep the angle blade at the standard 0° marking, as illustrated.
- Do not work under the machine.

- To adjust the blade angle to the right, twist the dozer control lever clockwise.
- To adjust the blade angle to the left, twist the dozer control lever counterclockwise.

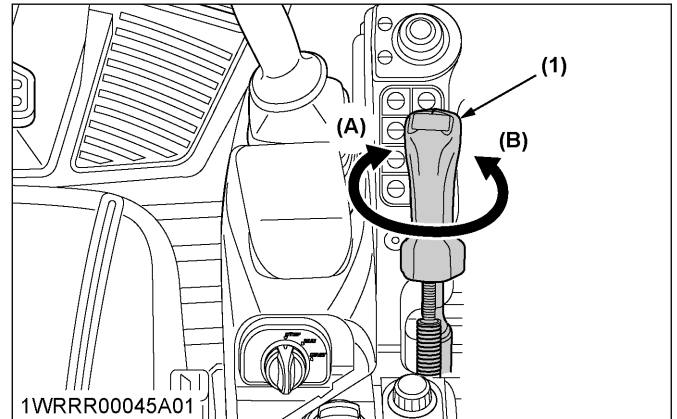

- (1) Dozer control lever (A) Turn to the right
(B) Turn to the left

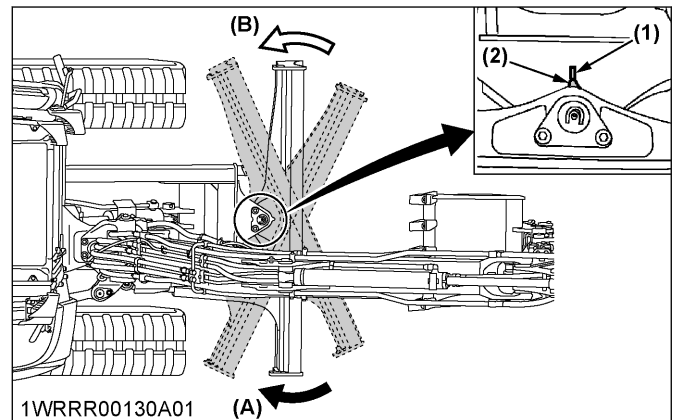

- (1) Mark (red) (A) Turn the right
(2) Mark (red) (B) Turn the left

6-IN-1 BLADE OPERATION [6-IN-1 BLADE TYPE]



WARNING

To avoid personal injury or death:

- Never jack up or lift the machine with the 6-in-1 blade placed at an angle. The machine will be ill-balanced and may fall down. Before starting the job, position and keep the 6-in-1 blade at the standard 0° marking.

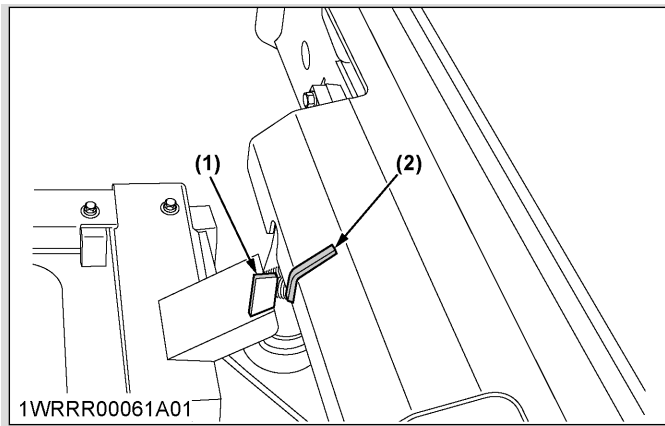

(1) Mark (red)
(2) Mark (red)

• Do not work under the machine.

The dozer control lever triples as the angle, tilt and standard blade control lever.

Angle blade operation

- To adjust the blade angle to the right, twist the dozer control lever clockwise.
- To adjust the blade angle to the left, twist the dozer control lever counterclockwise.

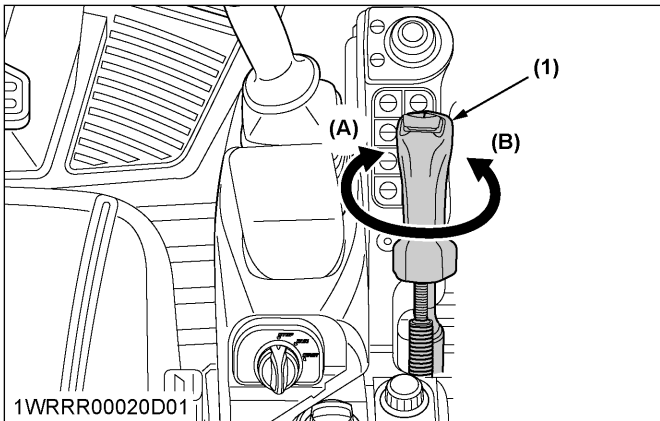

(1) Dozer control lever
(A) Turn to the right
(B) Turn to the left

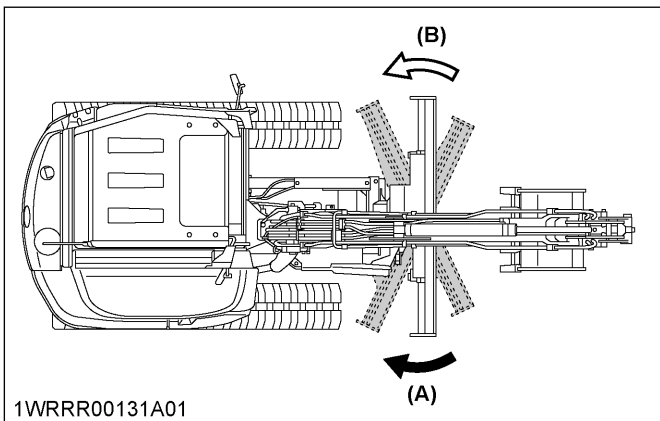

(A) Turn to the right
(B) Turn to the left

Tilt blade operation

- To tilt the blade to the right (as viewed from the operator's seat), push the tilt switch to the right.
- To tilt the blade to the left (as viewed from the operator's seat), push the tilt switch to the left.

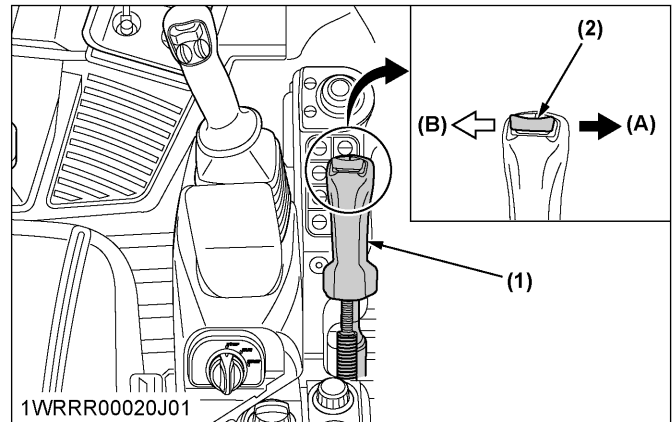

(1) Dozer control lever
(2) Tilt switch
(A) Tilt to the right
(B) Tilt to the left

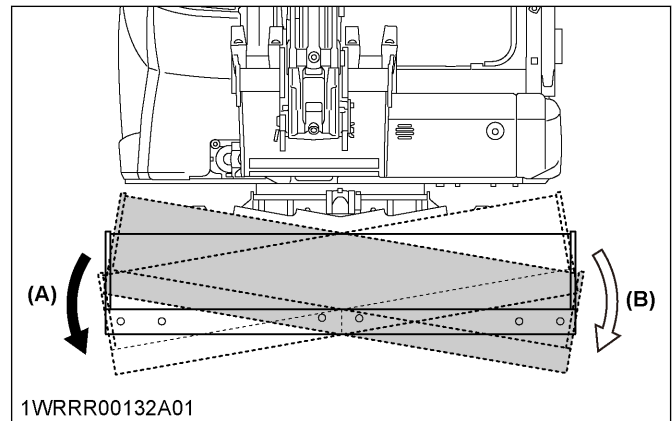

(A) Tilt to the right
(B) Tilt to the left

ONE-WAY OR TWO-WAY CIRCUIT SELECTION VALVE OPERATION

⚠ WARNING

To avoid personal injury or death:

- Stop the engine before removing or changing the attachment.
- Release the pressure from the hydraulic system before removing or changing the attachment. (See **RELEASING PRESSURE TRAPPED IN THE HYDRAULIC SYSTEM** on page 100.)
- In order to avoid sudden movement of the attachment, make sure that the selected operating mode is set to the correct circuit (one-way or two-way) before mounting the attachment.

(See Setting the maximum flow volume on page 97.)

NOTE :

- **Selecting an operating mode that is set to one-way circuit selection and attaching a two-way circuit attachment may cause the attachment to move (drop) suddenly due to its own weight, as the tank line remains open even with the engine off.**

The one-way or two-way selection valve is linked to the AUX operating mode. There is no need to control it in manual mode.

(See Setting the maximum flow volume on page 97.)

Change the AUX operating mode setting, depending on the action of the attachment being used (rotary or breaking).

Example

1-way circuit	Hammer, and so on.
2-way circuit	Thumb grapple, tilt bucket, auger, grapple, and so on.

OPERATING THE BOOM LOWERING VALVE

Use this valve if the engine fails to start and the accumulator fails to operate and there is an urgent need to lower the boom.

WARNING

To avoid personal injury or death:

- **When the engine functions, move the control lever to lower the boom. Never use the boom lowering valve.**
- **Loosen the boom lowering valve set screw slowly a quarter turn at a time. Be careful not to loosen it a full turn or more at once because otherwise oil may squirt out accidentally.**
- **Before starting this job, make sure there is nobody below the boom.**

1. Remove the floor mat.
2. Remove the step cover.
3. Loosen the boom lowering valve nut located below the control valve boom block first and then the set screw slowly.

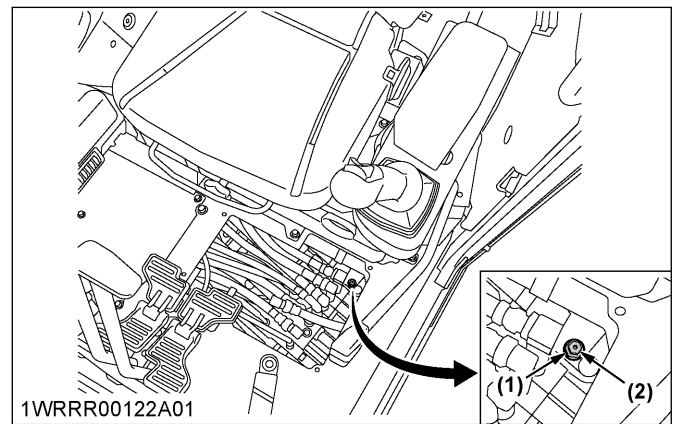

- (1) Nut
(2) Set screw

4. After this operation, tighten the boom lowering valve nut and the set screw in place.

AUTO IDLE (AI) OPERATION

Throttle potentiometer

With this potentiometer, the operator can adjust the engine speed when the Auto Idle control is activated.

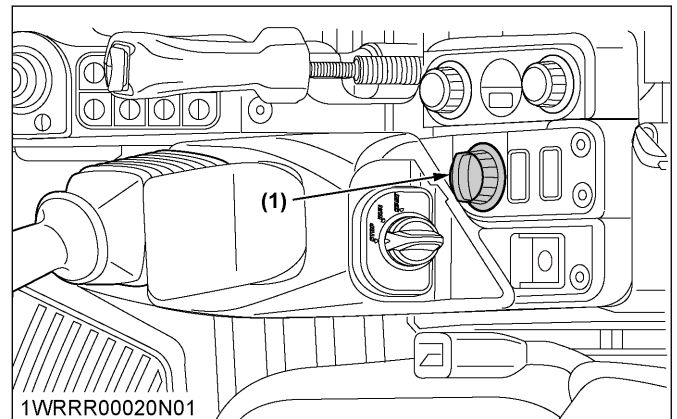

- (1) Throttle potentiometer

Auto Idle (AI) control switch

With this switch, the Auto Idle control is turned on or off. The Auto Idle control allows the engine speed to drop to idle speed when the control levers are left in neutral for longer than four seconds. If the control is activated, the engine speed rises immediately to the preset rpm. If the Auto Idle is not activated, the throttle potentiometer can be utilized to control engine speed in a similar way to a conventional throttle control lever.

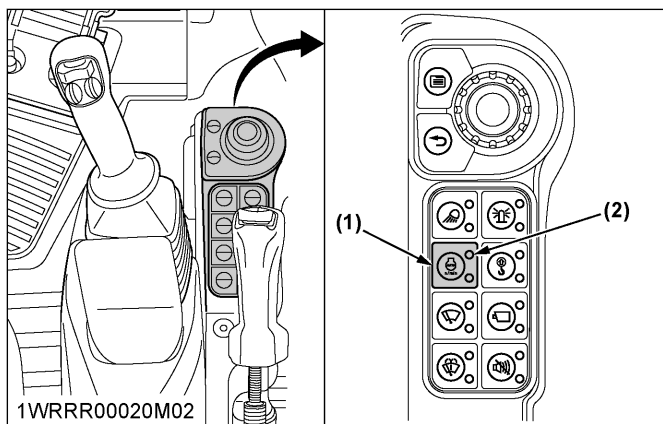

(1) Auto Idle control switch
(2) Auto Idle lamp

IMPORTANT :

- It is possible that the Auto Idle may not function until hydraulic oil warms up in cold weather. Therefore, it is not recommended to activate Auto Idle until the machine has completely warmed up.

NOTE :

- Before operating the control lever, check the Auto Idle lamp.
- When operating in confined spaces or when loading onto a vehicle, turn off the Auto Idle control switch (lamp off). This is to prevent unwanted engine speed increase when control levers are activated.
- The Auto Idle control, when selected by a switch, provides the operator with a way to control the engine speed without moving the throttle potentiometer. This is done simply by not activating any control levers for about 4 seconds after stopping work, and then to simply restore a preset (by potentiometer) engine speed, activate any control lever to return to work.
- The purpose of the system is to reduce fuel consumption, noise and operator fatigue.
- When the dozer control lever is locked at the "Float" position on the angle blade type, the Auto Idle function is not activated even if any other control lever is set to the neutral position.

IMPORTANT INFORMATION ON MACHINE OPERATION

- Do not crush concrete or boulders using side swings with the bucket. Also, avoid using side sweeps of the bucket to move earth piles.
- Under all circumstances, avoid the following operations:
 - Excavation using the gravitational impact of the machine.

- Compacting of gravel or soil using the dropping action of the bucket.
- Excavation using the traveling power of the machine.
- If soil adheres to the bucket, do not try to violently shake off the soil. This can cause damage to the machine. Instead, use the following technique: Shake off adhering soil when the bucket is being emptied by moving the bucket out to the maximum stroke of the cylinder. Should this not suffice, swing out the arm as far as possible and operate the bucket back and forth.
- Do not hit the dozer with the boom cylinder. Make sure that the boom cylinder does not hit the dozer when doing deep excavations. If necessary, swivel around so that the dozer is at the back of the machine.
- Pay attention when pulling in the bucket. When pulling in the bucket (for driving or transportation), avoid hitting the dozer.
- Avoid collisions with obstructions. When moving the machine, pay attention that the dozer does not collide with obstructions such as boulders, and so on.
- Support the machine correctly. When stabilizing the machine with the dozer, lower the dozer to engage the full width on the ground.
- If the water or mud level reaches higher than the top of the tracks, the swivel bearing, swivel motor gear and ring gear may be exposed to mud, water and other foreign objects. The machine must be properly pressure washed after each use.
 - Thoroughly clean the area around the swivel bearing, swivel motor gear and ring gear to remove foreign objects.
 - Inspect the swivel motor oil sump (if equipped) for water contamination. If water is present, refer to operator's manual for lubricant replacement procedure.
 - Refer to operator's manual for proper swivel bearing, swivel motor gear and ring gear lubrication procedures.
 - Reinstall any protective coverings if removed earlier.
- Avoid applying excessive load with the cylinders fully extended, as doing so can easily damage the machine.
- When relieving the residual pressure, do so immediately after the engine has stopped.

TRANSPORTING THE MACHINE

DANGER

To avoid serious injury or death:

- Do not change directions when the machine is on a ramp. If a change of direction is necessary, drive off the ramp completely and make the turn.

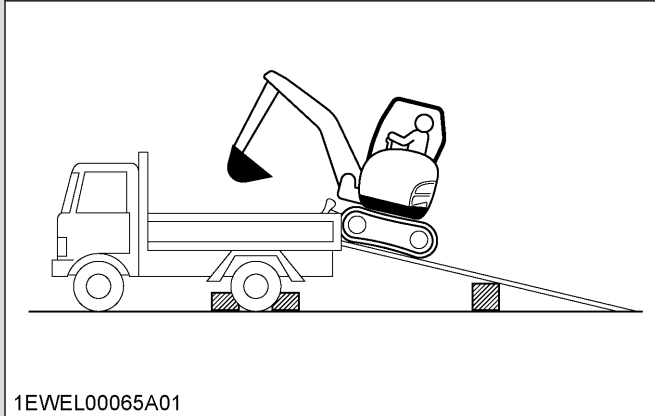

1EWEL00065A01

- When the machine reaches the point between the ramp and the bed, halt and then move very slowly until the machine reaches the horizontal position.
- Move the machine onto the vehicle only with the arm completely pulled in.
- Do not jack up the machine using its boom to load or unload the machine from the vehicle. Doing this is dangerous, as the CAB of the vehicle could be damaged when swiveling around the upper body.
- Make sure the ramps are of sufficient capacity and securely connected to the vehicle to support the machine safely throughout the loading or unloading operation.

IMPORTANT :

- When driving forward or backward onto the vehicle, or when swiveling the upper body, make sure that neither the CAB nor the gates of the vehicle are damaged.



TRANSPORTING ON A TRUCK

WARNING

To avoid personal injury or death:

- After loading the machine on the truck, lower the bucket and dozer onto the truck bed.

IMPORTANT :

- Turn the auto idle control switch “OFF” (lamp off) while loading or unloading the excavator from the vehicle.
- Turn the travel speed switch “OFF” (“*LOWSPEED*”) (speed indicator light changes from the  symbol to the  symbol) while loading or unloading the excavator from the vehicle.

Prepare a platform to load or unload the machine. Take the following steps when using a ramp.

1. Apply the parking brakes of the vehicle and block the drive wheels from both sides.

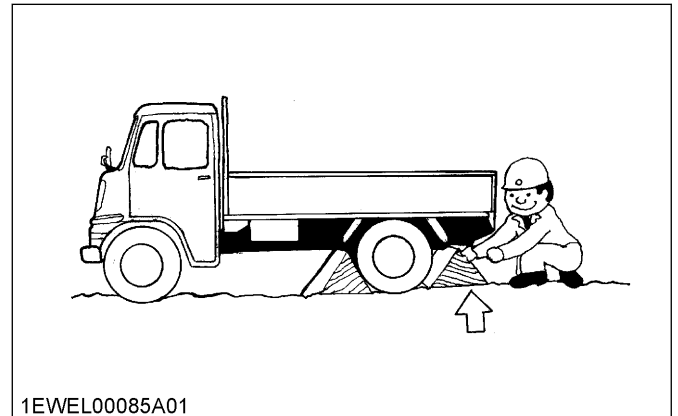

1EWEL00085A01

2. Use mounting brackets to secure the ramp properly. Connect the ramp directly with the bed.

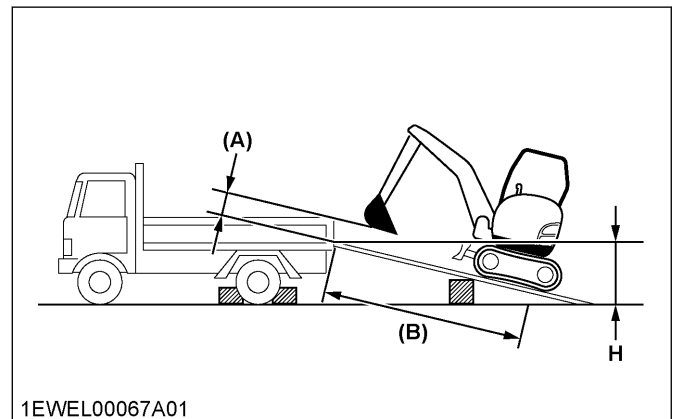

1EWEL00067A01

(A) 20 cm to 40 cm (8 in. to 16 in.)

(B) $4 \times H$ or more

- For additional safety, use blocks or supports under the ramp and the bed.

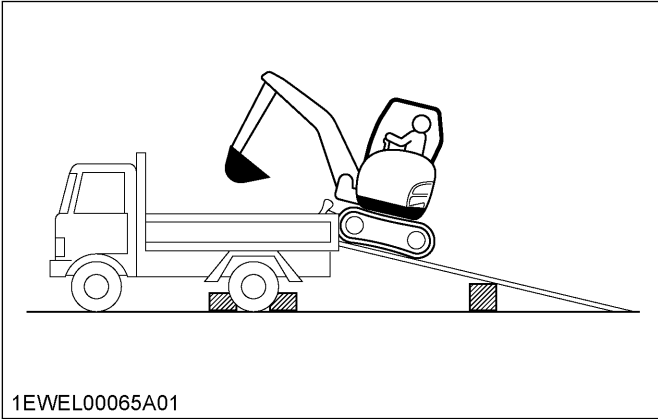

- Completely align the ramp and the tracks and then drive the machine slowly up the ramp. After ensuring that the tracks are completely on the bed, swivel the upper body around to the back of the vehicle.
- Lower the dozer onto the bed.
- Pull in the bucket and the arm completely and then lower the boom.
- Stop the engine, release the pressure trapped in the hydraulic system.
- Set the pilot control lock lever to the LOCK position.
- Block the tracks with blocks and tie down the machine.

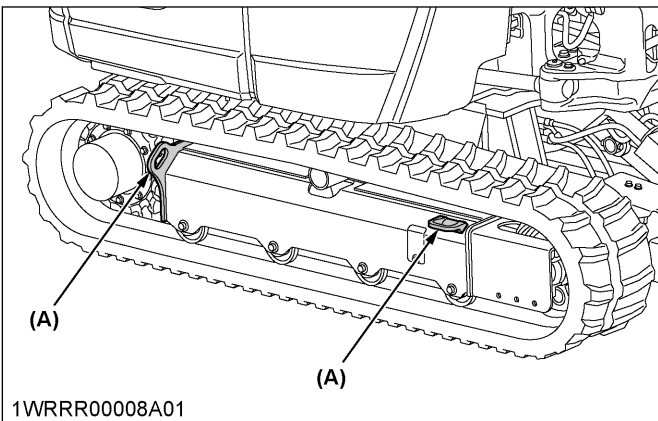

(A) Tie down point

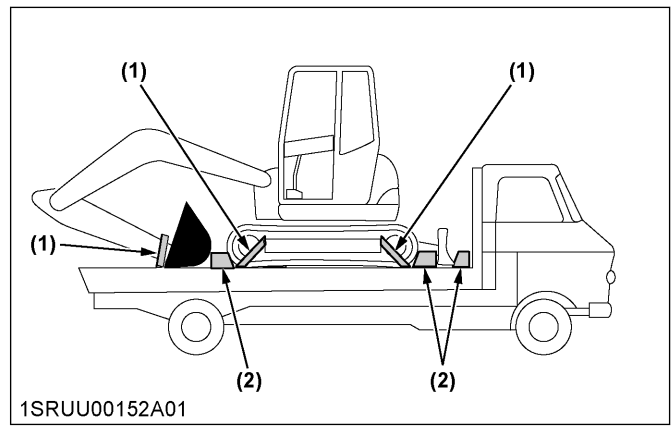

(1) Chain
(2) Block

TOWING THE MACHINE

WARNING

To avoid personal injury or death:

- When towing the machine or pulling a load, the load must be less than the strength of the towing line attached to the machine. Not to be used for tying down or lifting the machine.
- Towing is only allowed for a short distance and at walking speed.

- Attach the tow bar or towing rope to the hook on the machine and to the pulling vehicle. The tow bar should be mounted at a right angle to the vehicles.
- The operator must be seated during the recovery procedure.
- Drive slowly with the tractive vehicle to avoid abrupt loads.
(For the maximum drawbar pull and maximum vertical load, see SAFE LOADING AND TRANSPORT OF THE MACHINE on page 11.)

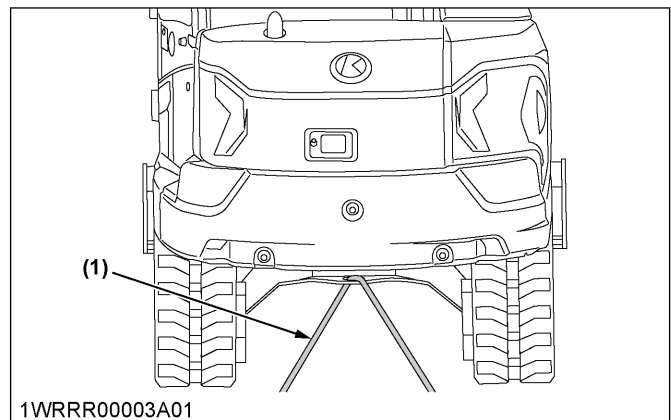

(1) Towing line

LIFTING THE EXCAVATOR



DANGER

To avoid serious injury or death:

- The correct instructions for safe handling are described here. Read these instructions before moving the machine.

BASIC POINTS WHEN LIFTING WITH CABLES OR STRAPS

- The lifting and crane operation is to be undertaken according to the safe operation guidelines described.
- The equipment used for lifting mentioned in these instructions are only given as reference. The standards concerning strength, control and other details are based on the respective applicable guidelines.

SAFETY ASPECTS WHEN LIFTING WITH CABLES OR STRAPS

Abide by the following steps when lifting:

- Do not lift loads that exceed the maximum load capacity of the crane.
- Choose correct equipment suitable to the weight, size and form of the load.
- Do not use steel cables or straps that show signs of wear and tear.
- First, assess the center of gravity of the load, position the hook directly over the load and lift the load so that the center of gravity of the load is as low as possible.
- The steel cables or straps must be fixed in the middle of the hook.
- The load must be lifted vertically from the ground.
- Do not enter the working area under suspended loads and do not move the load over people. The load must only be moved in an area where the balance can be easily maintained.

LIFTING THE MACHINE



WARNING

To avoid personal injury or death:

- Do not use the hooks on the roof of canopy and CAB for lifting the machine.

- When applying the shackles through the boom's and blade's openings for lifting, use two-point lifting for added safety.
- Never lift the machine with the angle blade turned at an angle [Angle blade type].
- Never lift the machine with the 6-in-1 blade turned or titled at an angle [6-in-1 blade type].

NOTE :

- While lifting, carefully keep the machine well balanced with its center of gravity in mind.
- Do not lift the machine with the boom swinging or the upper structure swiveling.

LIFTING THE EXCAVATOR

General guidelines for lifting

1. Prepare the machine for lifting as follows (see illustration for correct lifting position):
 - a. Rotate the upper swivel structure until the blade positions itself 180-degree opposite to the attachment.
 - b. Raise the blade completely.
 - c. Raise the boom and put the bucket and arm in their crowded positions.
 - d. Set the pilot control lock lever to the LOCK position.
 - e. With the boom not swinging, set the swing pedal to the neutral position, place the pedal cover and stop the engine.
 - f. Apply shackles (3200 kg or heavier duty) through the openings at both ends of the blade, and apply shackles (2000 kg or heavier duty) through the two openings at the boom top. Pass wire ropes through these shackles.

- Keep the angle between the front and rear cables or straps within the angles listed in the following tables.

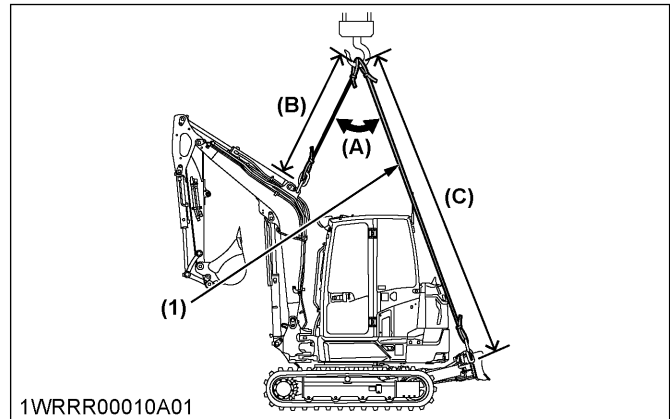

(1) Cable or strap

	Standard blade	Angle blade	6-in-1 blade
(A)	40° or less	40° or less	40° or less
(B)	2150 mm (84.6 in.)	2120 mm (83.5 in.)	2180 (85.8 in.)
(C)	4450 mm (175.2 in.)	4380 mm (172.4 in.)	4420 mm (174.0 in.)

Blade ends

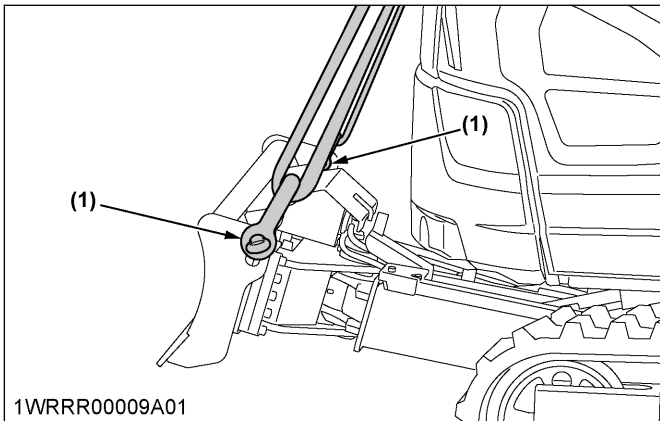

(1) Shackle

Boom top

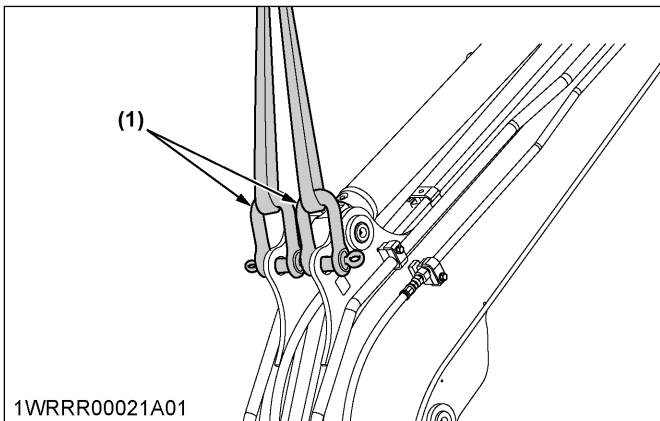

(1) Shackle

- Tackle:
The weight of the machine and the recommended tackle for lifting these loads are mentioned in the following table. Choose components with enough strength.

	Standard blade	Angle blade	6-in-1 blade
Machine weight*1	4300 kg (9480 lbs)	4495 kg (9910 lbs)	4650 kg (10250 lbs)
Load/cable	15.5 kN (3487 lbf)		
Minimum wire diameter (safety factor 6)	16 mm (5/8 in.) or more		

*1 Machine weight: With CAB, steel tracks. Steel wire: 6×24

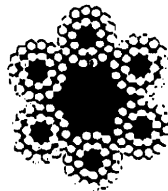

1EWEL00019A01

2. Attach the steel wires while observing the following safety points:
 - Always hook the machine at three points. One on the boom and left and right of the dozer.
 - Always use a shackle on each lifting hole when attaching the cables or straps.

3. Lift the machine while observing the following safety points:
- Lift slowly and safely.
 - Do not enter the machine area when lifting.
 - Lift the machine horizontally. Modify cable or strap connections according to needs.

Maximum strength

(JIS G3525: 2006 or ISO 4344: 2004) -6×24

Diameter	Zinc-plated	Not zinc-plated
14 mm (9/16)	89.7 kN (20165 lbf)	96.6 kN (21717 lbf)
16 mm (5/8)	117 kN (26303 lbf)	126 kN (28326 lbf)
18 mm (45/64)	148 kN (33272 lbf)	160 kN (35969 lbf)
20 mm (3/4)	183 kN (41140 lbf)	197 kN (44287 lbf)
22.4 mm (—)	230 kN (51706 lbf)	247 kN (55528 lbf)

MAINTENANCE

WARNING

To avoid personal injury or death:

- Before refueling or performing maintenance on the machine, take the following steps:
 1. Park the machine on a firm, flat, and level surface.
 2. Lower the attachments and the dozer blade to the ground.
 3. Stop the engine.
 4. Release the pressure from the hydraulic system.
 5. Check the machine and the surrounding area for any potential safety issues.
- Thoroughly read and understand the safety warnings in this manual before performing any work on the machine.
(See MAINTENANCE on page 12.)

PRECAUTIONS WHEN WASHING THE MACHINE

WARNING

To avoid personal injury or death:

- Set the nozzle of the pressure washer to a low-pressure setting or use a low-pressure nozzle, and maintain a distance of at least 2 m from the machine when washing it. If the spray is concentrated in a single spot, or if the machine is washed from too close with a high-pressure flow, the following accidents, machine damage, and malfunctions may occur:
 - The wire coverings may be damaged or the wiring may be severed, causing a fire.
 - The hydraulic hoses may be damaged, causing a high-pressure oil blowout, which may cause injury.
 - The stickers or safety labels may peel off.
 - Water may seep into the electronic components, the engine compartment, the cabin, or other parts of the machine, leading to damage or malfunctions.
 - The water may cause damage to the rubber based components such as the tracks and the oil seals, to the decorative covers and other plastic-based components, or to the windows and other glass-based components.

- The paint, coatings, and plating may peel off.

IMPORTANT :

- Water entering the electrical system can cause malfunctions. Do not spray water directly on electrical components such as sensors or connectors.
- If you wash the machine while the engine is running, water can splash and get into the air cleaner through its intake and cause engine damage. Be careful not to spray water on the air cleaner.

When misused, pressure washers can cause personal injury and machine damage. Always operate the pressure washer correctly and safely in accordance with its operator's manual and safety labels.

Do not use a high-pressure nozzle or setting

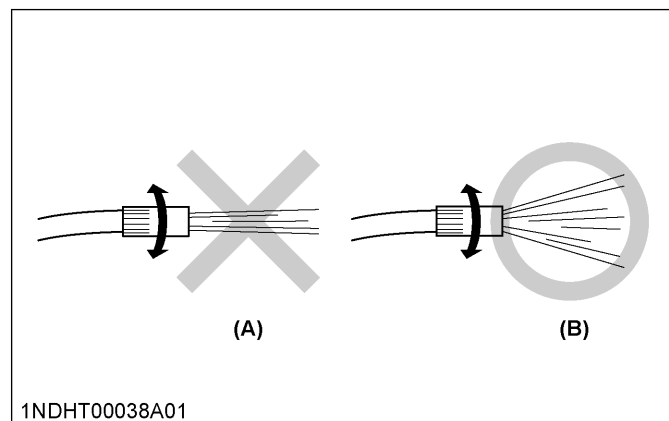

(A) High pressure (B) Low pressure

Do not wash from close range

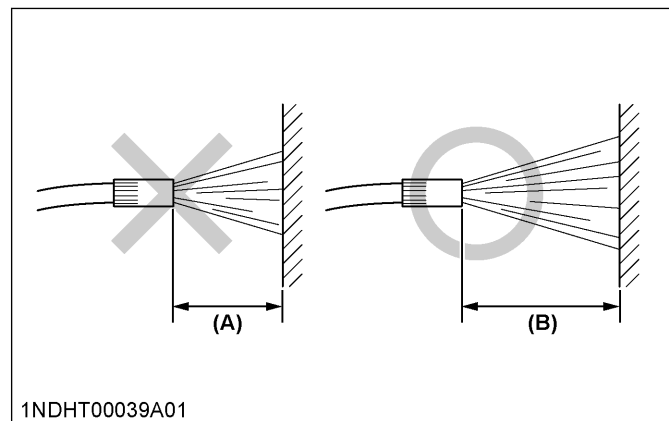

(A) Less than 2 m (B) 2 m or more

MAINTENANCE INTERVALS

No.	Check points		Measures	Hour meter indicator										Interval	Ref. page			
				50	100	150	200	250	300	350	400	450	500					
1	Walk-around inspection		Check	Daily check											120			
2	Coolant		Check	Daily check											120			
			Change												Every 2 years	146		
3	Fuel		Check	Daily check											121			
4	Engine oil		Check	Daily check											121			
			Change											o	Every 500 hrs	137		
5	Hydraulic oil		Check	Daily check											122			
			Change												Every 1000 hrs	141	*1	
6	Water separator		Check	Daily check											123			
			Clean	o	o	o	o	o	o	o	o	o	o	o	Every 50 hrs	129		
			Drain												Service as re-quired	149		
7	Radiator and oil cooler		Check	Daily check											123			
8	ROPS		Check	Daily check											124			
9	Filter indicator		Check	Daily check											124			
10	Fan belt tension		Check	Daily check											125			
			Adjust					o						o	Every 250 hrs	136		
11	Washer liquid		Check	Daily check											125			
12	Engine and electrical wiring		Check	Daily check											125			
13	Evacuator valve		Check	Daily check											125			
			Clean				o					o			Every 200 hrs	134		
14	DPF muffler		Check	Daily check											125			
15	Exhaust leaks		Check	Daily check											126			
16	Electrical equipment		Check	Daily check											126			
17	Seat belt		Check	Daily check											126			
18	Front attachments		Grease	Daily check											126			
19	Fuel tank		Drain	o	o	o	o	o	o	o	o	o	o	Every 50 hrs	129			
20	Battery condition		Check	o	o	o	o	o	o	o	o	o	o	Every 50 hrs	129			
21	Swivel bearing teeth		Grease	o	o	o	o	o	o	o	o	o	o	Every 50 hrs	131			
22	Tracks		Check	o	o	o	o	o	o	o	o	o	o	Every 50 hrs	131			
23	Radiator hoses and clamps		Check				o				o		Every 200 hrs	132				
			Replace											Every 2 years	145			
24	Swivel ball bearing		Grease				o				o		Every 200 hrs	133				
25	Air filter element	Outer element	Clean				o				o		Every 200 hrs	133	*2	@		

(Continued)

No.	Check points		Measures	Hour meter indicator										Interval	Ref. page		
				50	100	150	200	250	300	350	400	450	500				
25	Air filter element	Outer element	Replace											Every 1000 hrs	144	*2	@
		Inner element	Replace											Every 1000 hrs	144	*2	
26	Fuel line and intake air line		Check				○						○	Every 200 hrs	134		@
			Replace											Every 2 years	147	*3	
27	Pilot valve linkage		Grease					○					○	Every 250 hrs	137		
28	Water separator filter element		Replace										○	Every 500 hrs	137		
29	Engine oil filter		Replace										○	Every 500 hrs	138		
30	Drive unit oil		Change	◎									○	Every 500 hrs	139		
31	Fuel filter cartridge		Replace										○	Every 500 hrs	139		@
32	Hydraulic oil tank breather filter		Replace										○	Every 500 hrs	139		
33	Hydraulic pilot filter element		Replace											Every 1000 hrs	140		
34	Hydraulic return filter element		Replace											Every 1000 hrs	141		
35	Hydraulic suction filter element		Replace											Every 1000 hrs	141		
36	Auxiliary valve filter		Clean											Every 1000 hrs	143		
37	Pilot line filter		Clean											Every 1000 hrs	143		
38	Engine valve clearance		Check											Every 1000 hrs	143	*4	
39	Injector tip		Check											Every 1500 hrs	144	*4	@
40	EGR cooler		Check											Every 1500 hrs	144	*4	@
41	Front idler and track roller oil		Change											Every 2000 hrs	144		
42	Alternator and starter motor		Check											Every 2000 hrs	144		
43	EGR system		Check											Every 3000 hrs	144	*4	@
44	Turbo charger		Check											Every 3000 hrs	144	*4	@
45	Electrical wiring and fuses		Check											Every 1 year	144		
46	Exhaust manifold (cracks, gas leakage and mounting screw)		Check											Every 1 year	145	*4	
47	Intake air line for air leaks		Check											Every 1 year	145	*4	
48	Boost sensor and AFS (Air Flow Sensor)		Check											Every 1 year	145	*4	
49	Condition of DPF muffler		Check											Every 1 year	145	*4	

(Continued)

No.	Check points	Measures	Hour meter indicator										Interval	Ref. page			
			50	100	150	200	250	300	350	400	450	500					
50	DPF differential pressure sensor and piping for gas leaks	Check												Every 1 year	145	*4	
51	DPF exhaust gas temperature sensor	Check												Every 1 year	145	*4	
52	EGR piping for gas leaks	Check												Every 1 year	145	*4	
53	DPF differential pressure sensor rubber piping (front and back)	Replace												Every 2 years	148	*4	
54	Suction pipe downstream the AFS (Air Flow Sensor)	Replace												Every 2 years	148	*4	
55	EGR cooler hoses	Replace												Every 2 years	148	*4	
56	Hydraulic hoses	Replace												Every 2 years or 4000 hrs	148 159	*4	
57	DPF	Clean												Service as required	149	*4	@
58	Plastic parts and synthetic leather	Clean												Service as required	149		

* 500 through 3000 continued in the following table.

- *1 When using a hydraulic hammer, change hydraulic oil and return filter according to the hydraulic oil change table. (See Checking the hydraulic oil (hydraulic hammer operation) on page 143.)
- *2 Clean and replace the air filter more frequently if used in dusty conditions. When the filter is very dirty due to dusty conditions, replace the filter.
- *3 Replace only if necessary.
- *4 Contact your local Kubota dealer for this service.

IMPORTANT :

- The items marked as **⊙** should be done after the first operation.
- The items marked as **(@)** are registered as emission related critical parts by Kubota in the U.S. EPA nonroad emission regulation. As the engine owner, you are responsible for performing required maintenance of the engine, according to the above instructions. Please see the warranty statement in detail.
- When using biodiesel, check the maintenance requirements of biodiesel fuel as the intervals will change in some of the items.

No.	Check points		Measures	Hour meter indicator								Interval	Ref. page				
				550	600	650	700	750	800	1000	1500					3000	
1	Walk-around inspection		Check	Daily check									120				
2	Coolant		Check	Daily check									120				
			Change										Every 2 years	146			
3	Fuel		Check	Daily check									121				
4	Engine oil		Check	Daily check									121				
			Change							o	o	o	Every 500 hrs	137			
5	Hydraulic oil		Check	Daily check									122				
			Change							o		o	Every 1000 hrs	141	*1		
6	Water separator		Check	Daily check									123				
			Clean	o	o	o	o	o	o	o	o	o	o	Every 50 hrs	129		
			Drain											Service as required	149		
7	Radiator and oil cooler		Check	Daily check									123				
8	ROPS		Check	Daily check									124				
9	Filter indicator		Check	Daily check									124				
10	Fan belt tension		Check	Daily check									125				
			Adjust					o		o	o	o	Every 250 hrs	136			
11	Washer liquid		Check	Daily check									125				
12	Engine and electrical wiring		Check	Daily check									125				
13	Evacuator valve		Check	Daily check									125				
			Clean		o					o		o	Every 200 hrs	134			
14	DPF muffler		Check	Daily check									125				
15	Exhaust leaks		Check	Daily check									126				
16	Electrical equipment		Check	Daily check									126				
17	Seat belt		Check	Daily check									126				
18	Front attachments		Grease	Daily check									126				
19	Fuel tank		Drain	o	o	o	o	o	o	o	o	o	Every 50 hrs	129			
20	Battery condition		Check	o	o	o	o	o	o	o	o	o	Every 50 hrs	129			
21	Swivel bearing teeth		Grease	o	o	o	o	o	o	o	o	o	Every 50 hrs	131			
22	Tracks		Check	o	o	o	o	o	o	o	o	o	Every 50 hrs	131			
23	Radiator hoses and clamps		Check		o				o	o		o	Every 200 hrs	132			
			Replace										Every 2 years	145			
24	Swivel ball bearing		Grease		o					o		o	Every 200 hrs	133			
25	Air filter element	Outer element	Clean		o				o	o		o	Every 200 hrs	133	*2	@	
			Replace							o		o	Every 1000 hrs	144	*2		

(Continued)

No.	Check points		Measures	Hour meter indicator								Interval	Ref. page				
				550	600	650	700	750	800	1000	1500					3000	
25	Air filter element	Inner element	Replace								○		○	Every 1000 hrs	144	*2	@
26	Fuel line and intake air line		Check		○						○		○	Every 200 hrs	134		@
			Replace												Every 2 years	147	
27	Pilot valve linkage		Grease					○		○	○	○	○	Every 250 hrs	137		
28	Water separator filter element		Replace								○	○	○	Every 500 hrs	137		
29	Engine oil filter		Replace								○	○	○	Every 500 hrs	138		
30	Drive unit oil		Change								○	○	○	Every 500 hrs	139		
31	Fuel filter cartridge		Replace								○	○	○	Every 500 hrs	139		@
32	Hydraulic oil tank breather filter		Replace								○	○	○	Every 500 hrs	139		
33	Hydraulic pilot filter element		Replace								○		○	Every 1000 hrs	140		
34	Hydraulic return filter element		Replace								○		○	Every 1000 hrs	141		
35	Hydraulic suction filter element		Replace								○		○	Every 1000 hrs	141		
36	Auxiliary valve filter		Clean								○		○	Every 1000 hrs	143		
37	Pilot line filter		Clean								○		○	Every 1000 hrs	143		
38	Engine valve clearance		Check								○		○	Every 1000 hrs	143	*4	
39	Injector tip		Check									○	○	Every 1500 hrs	144	*4	@
40	EGR cooler		Check									○	○	Every 1500 hrs	144	*4	@
41	Front idler and track roller oil		Change											Every 2000 hrs	144		
42	Alternator and starter motor		Check											Every 2000 hrs	144		
43	EGR system		Check										○	Every 3000 hrs	144	*4	@
44	Turbo charger		Clean										○	Every 3000 hrs	144	*4	@
45	Electrical wiring and fuses		Check											Every 1 year	144		
46	Exhaust manifold (cracks, gas leakage and mounting screw)		Check											Every 1 year	145	*4	
47	Intake air line for air leaks		Check											Every 1 year	145	*4	
48	Boost sensor and AFS (Air Flow Sensor)		Check											Every 1 year	145	*4	
49	Condition of DPF muffler		Check											Every 1 year	145	*4	
50	DPF differential pressure sensor and piping for gas leaks		Check											Every 1 year	145	*4	

(Continued)

No.	Check points	Measures	Hour meter indicator									Interval	Ref. page			
			550	600	650	700	750	800	1000	1500	3000					
51	DPF exhaust gas temperature sensor	Check											Every 1 year	145	*4	
52	EGR piping for gas leaks	Check											Every 1 year	145	*4	
53	DPF differential pressure sensor rubber piping (front and back)	Replace											Every 2 years	148	*4	
54	Suction pipe downstream the AFS (Air Flow Sensor)	Replace											Every 2 years	148	*4	
55	EGR cooler hoses	Replace											Every 2 years	148	*4	
56	Hydraulic hoses	Replace											Every 2 years or 4000 hrs	148 159	*4	
57	DPF	Clean											Service as required	149	*4	@
58	Plastic parts and synthetic leather	Clean											Service as required	149		

- *1 When using a hydraulic hammer, change hydraulic oil and return filter according to the hydraulic oil change table. (See Checking the hydraulic oil (hydraulic hammer operation) on page 143.)
- *2 Clean and replace the air filter more frequently if used in dusty conditions. When the filter is very dirty due to dusty conditions, replace the filter.
- *3 Replace only if necessary.
- *4 Contact your local Kubota dealer for this service.

IMPORTANT :

- The items marked as **⦿** should be done after the first operation.
- The items marked as **(@)** are registered as emission related critical parts by Kubota in the U.S. EPA nonroad emission regulation. As the engine owner, you are responsible for performing required maintenance of the engine, according to the above instructions. Please see the warranty statement in detail.
- When using biodiesel, check the maintenance requirements of biodiesel fuel as the intervals will change in some of the items.

1. Air conditioner

No.	Check points	Measures	Hour meter indicator								Interval	Ref. page	
			50	100	150	200	250	300	350	400			450
1	Air conditioner belt	Check	Daily check									125	
		Adjust					○				Every 250 hrs	136	
2	Air conditioner filter	Clean			○			○		○	Every 150 hrs	131	*1
		Replace									Every 600 hrs	—	*1
3	Air conditioner condenser	Clean			○				○		Every 200 hrs	135	
4	Air conditioner pipes and hoses	Check									Every 1 year	144	
		Replace									Every 2 years	145	
5	Refrigerant (gas)	Check									Service as required	148	

*1 Clean and replace the air conditioner filter more frequently if used in dusty conditions. When the filter is very dirty due to dusty conditions, replace the filter.

No.	Check points	Measures	Hour meter indicator							Interval	Ref. page		
			500	550	600	650	700	750	800			1000	
1	Air conditioner belt	Check	Daily check								125		
		Adjust	○					○		○	Every 250 hrs	136	
2	Air conditioner filter	Clean			○			○			Every 150 hrs	131	*1
		Replace			○						Every 600 hrs	—	*1
3	Air conditioner condenser	Clean			○				○	○	Every 200 hrs	135	
4	Air conditioner pipes and hoses	Check									Every 1 year	144	
		Replace									Every 2 years	145	
5	Refrigerant (gas)	Check									Service as required	148	

*1 Clean and replace the air conditioner filter more frequently if used in dusty conditions. When the filter is very dirty due to dusty conditions, replace the filter.

OPENING AND CLOSING THE COVERS

1. Opening and closing the engine hood

WARNING

To avoid personal injury or death:

- Do not open the engine hood with the engine running, unless it is an emergency.
- Do not touch the exhaust muffler or the exhaust pipe. This can cause serious burns.

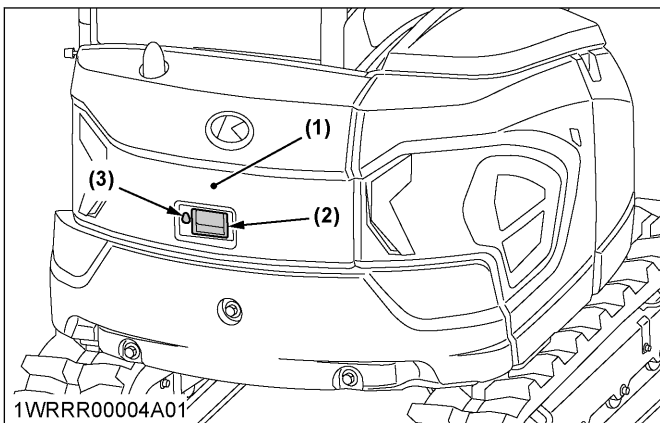

- (1) Engine hood
 (2) Catch
 (3) Key slot

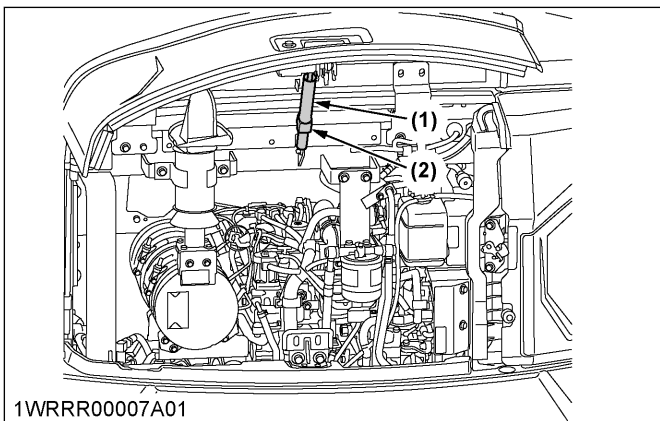

- (1) Gas spring
 (2) Stopper

Opening

1. Insert the key into the key slot and turn it clockwise to unlock the hood.
2. Pull the catch to unlatch the hood.
3. Lift the hood upwards until the stopper locks the gas spring into place.

Closing

1. Push the stopper upwards to release the gas spring.
2. Lower the hood until it clicks into its closed position.
3. Turn the key counterclockwise to lock the hood.

2. Opening and closing the fuel tank cover

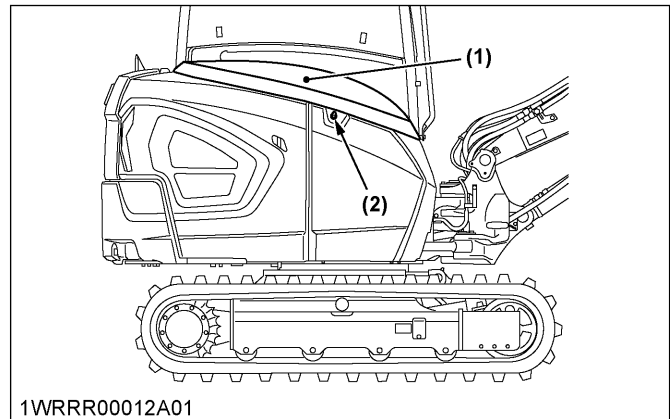

- (1) Fuel tank cover
 (2) Key slot

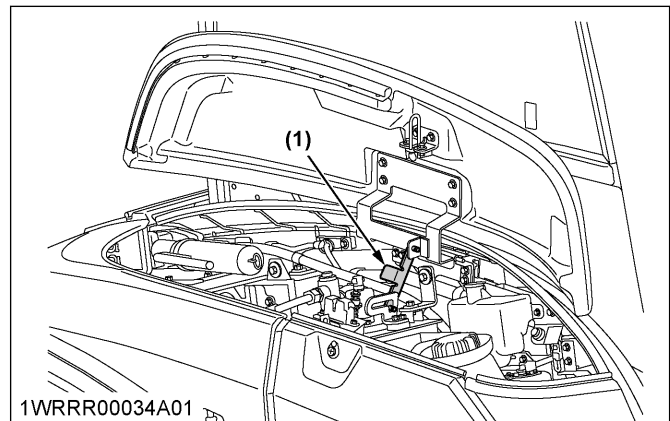

- (1) Stay

Opening

1. Insert the key into the key slot and turn it clockwise to unlock the fuel tank cover.
2. Lift the fuel tank cover upwards until the stay locks it in place.

Closing

1. Release the stay.
2. Lower fuel tank cover until it clicks into its closed position.
3. Turn the key counterclockwise to lock the fuel tank cover.

IMPORTANT :

- Take appropriate measures to insure that fuel is not contaminated during the re-fueling operation.

3. Opening and closing the side cover

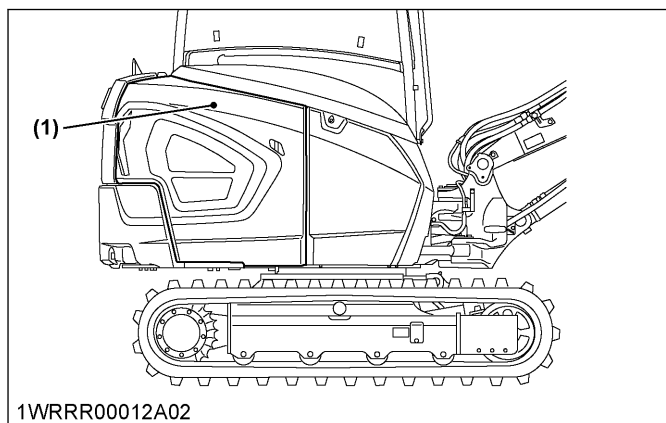

1WRRR00012A02

(1) Side cover

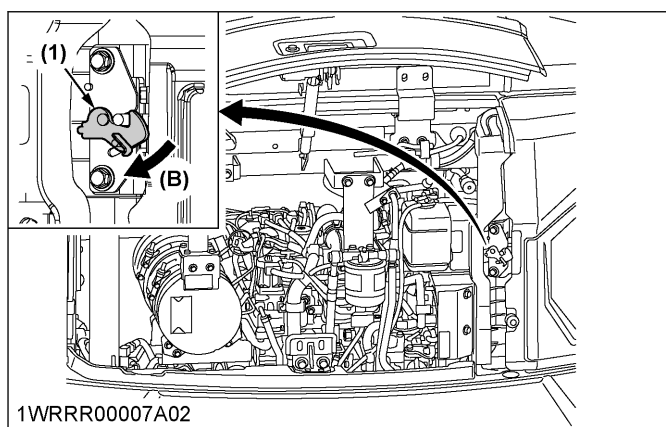

1WRRR00007A02

(1) Hook

(A) Push

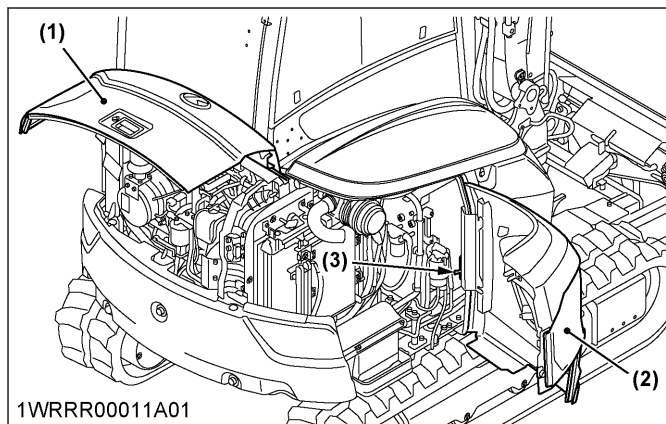

1WRRR00011A01

(1) Engine hood
(2) Side cover
(3) Unlock lever

Opening

1. Open the engine hood.
2. Push down on the hook to unlatch the side cover.
3. Open the side cover until it locks into place.

Closing

1. Pull the unlock lever upwards to release.
2. Lower the side cover until it clicks into its closed position.

3. Close the engine hood.

4. Storing tools

The toolbox is located behind the fuel tank cover, to the right of the hydraulic tank.

1. Open the fuel tank cover.
2. Store the tools in the storage box.

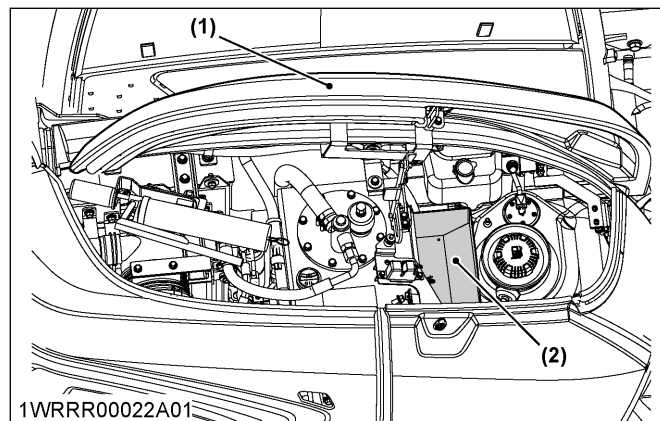

1WRRR00022A01

(1) Fuel tank cover
(2) Toolbox

5. Cup holder

The cup holder is located next to the operator's seat.

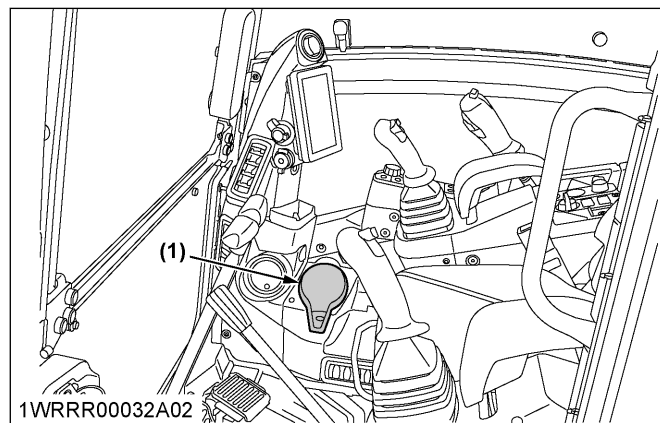

1WRRR00032A02

(1) Cup holder

6. Where to store the grease gun

- Open the fuel tank cover, and the grease gun storage spot can be found inside.
- After using the grease gun, secure it back to its fixture and close the fuel tank cover. If grease is collected in the grease receiver, wipe it clean with waste cloth or the like.
- Take note of the storage position of the grease gun shown in the following illustration.

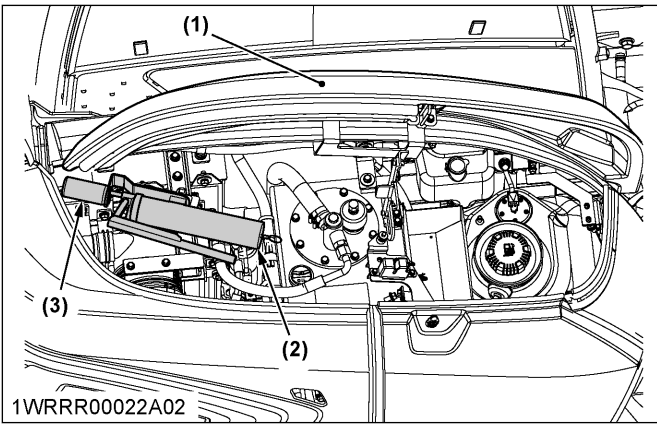

- (1) Fuel tank cover
- (2) Grease gun
- (3) Grease receiver

7. Where to keep the operator's manual

The operator's manual is located in the back of the seat.

[Canopy type]

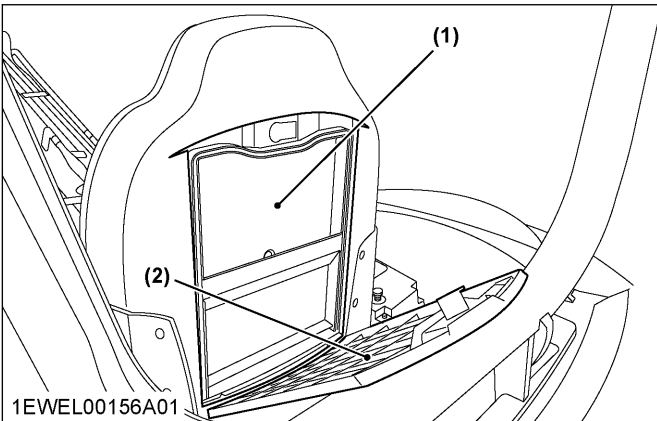

- (1) Operator's manual storage
- (2) Rear cover

[CAB type]

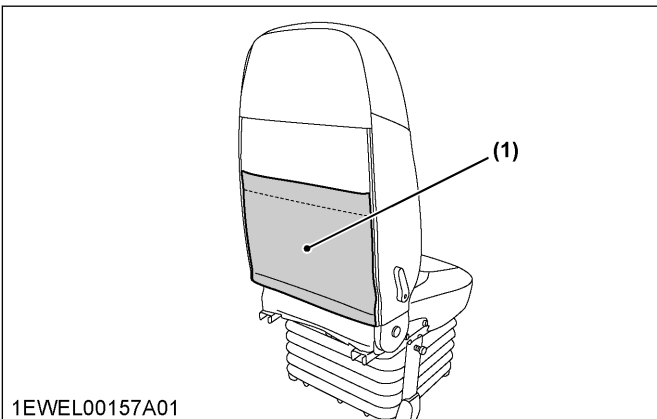

- (1) Operator's manual storage

DAILY CHECKS

For your own safety and to assure a long operating life of your machine, careful checks should be made before each operation.

! WARNING

To avoid personal injury or death:

- When operating, keep hands and body inside of the ROPS or OPG (top guard level I).
- Do not touch the control levers and pedals from outside the CAB while the engine is running.

1. Walk-around inspection

! WARNING

To avoid personal injury or death:

- Check the hot parts for any buildup of flammable materials, as such buildup can lead to a fire.

1. Check the machine for visible damage, loose nuts and screws, and leaks.
2. Check for any accumulated dirt adjacent to hot components (such as the engine or exhaust manifold), and remove as necessary.
3. Check for accumulated residue from leaves, straw, pine needles, twigs, barks, or any other flammable materials, and remove as necessary.
4. Check the safety labels on the machine, and ensure that they are completely legible.
(See SAFETY LABELS on page 17.)

2. Checking the coolant level

! WARNING

To avoid personal injury or death:

- Move the machine to even ground.
- Make sure that the engine is turned off.
- Do not open the radiator cap right after the engine has been stopped. It can cause serious burns on contact with escaping hot coolant fluid.
- Check the coolant level in the recovery tank only after the engine has cooled down.
- Remove the radiator cap only if absolutely necessary.

The radiator has a recovery tank. Should the coolant level in the radiator sink, the water will be automatically forwarded to the radiator.

1. Open the engine hood.
(See Opening and closing the engine hood on page 118.)

- Check the coolant level in the recovery tank and fill up if necessary. The coolant level should be between the marks **[FULL]** and **[LOW]**.

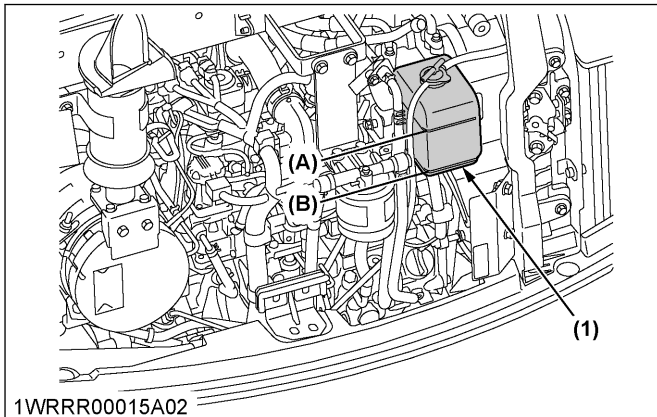

1WRRR00015A02

- (1) Recovery tank
 (A) FULL
 (B) LOW

IMPORTANT :

- Do not fill the recovery tank over the **[FULL]** marking.
- Do not fill with dirty or salty water.

3. Checking the fuel level

⚠ WARNING
 To avoid personal injury or death:

- Stop the engine before fueling.
- Do not smoke while fueling.
- Tighten the fuel cap after refueling.

IMPORTANT :

- When the temperature is over $-5\text{ }^{\circ}\text{C}$, use No.2-D diesel fuel. When the temperature is below $-5\text{ }^{\circ}\text{C}$, use No.1-D diesel fuel.
- Make sure that the fuel tank does not run empty. Air will enter the fuel system, and then it must be purged before restarting. (See **PURGING THE FUEL SYSTEM** on page 150.)
- To prevent condensation (water) accumulation in the fuel tank, fill the fuel into the tank before parking overnight.
- Be very aware of the remaining fuel level so that the engine does not stall. If the engine stalls, it may fail to get restarted for a while. This is to protect the emission purifying device.

- Turn the starter switch to the **[RUN]** position.

NOTE :

- Even when the machine is off, press the jog dial, and then the display shows the hour meter, fuel gauge, water temperature gauge, and clock for 10 seconds.

- Check the fuel level by looking at the fuel level indicator.

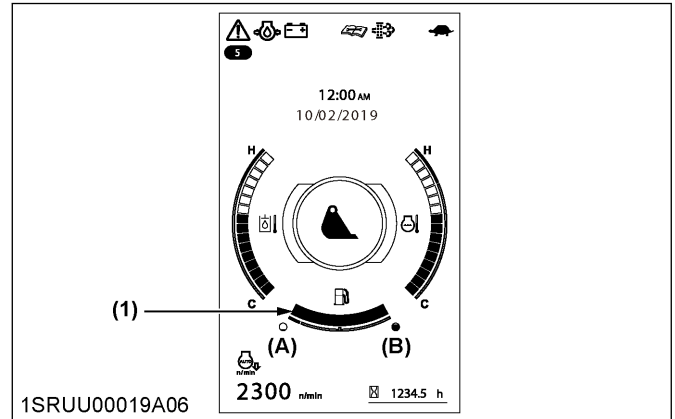

1SRUU00019A06

- (1) Fuel gauge
 (A) EMPTY
 (B) FULL

- If necessary, open the cap and fill with fuel.

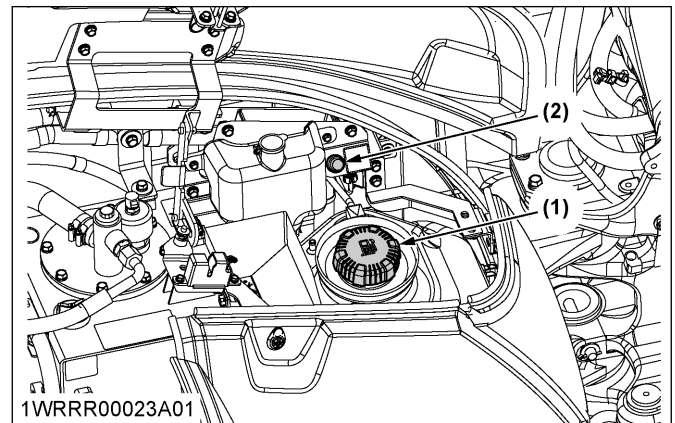

1WRRR00023A01

- (1) Fuel tank cap
 (2) Fuel level audible indication switch

Fuel tank capacity	66 L (17.4 U.S.gals)
--------------------	----------------------

IMPORTANT :

- Users must take appropriate actions to insure fuel is not contaminated during the refueling operation.

4. Checking the engine oil level

⚠ WARNING
 To avoid personal injury:

- Stop the engine before checking the oil level.

IMPORTANT :

- Use engine oil with the correct viscosity (according to the outside temperature).
- After stopping the engine, wait for 5 minutes and then check the oil level.
- On DPF-equipped engines, part of the fuel may get mixed with engine oil during the

regenerating process. This may dilute the oil and increase its quantity. If the oil rises above the oil level gauge upper limit, it means the oil has been diluted too much, resulting in a trouble. In such case, immediately change the oil.

1. Park the machine on a firm, flat and level surface, stop the engine.
2. Insert the engine oil dipstick fully into the opening.
3. Remove the dipstick and check the oil level.

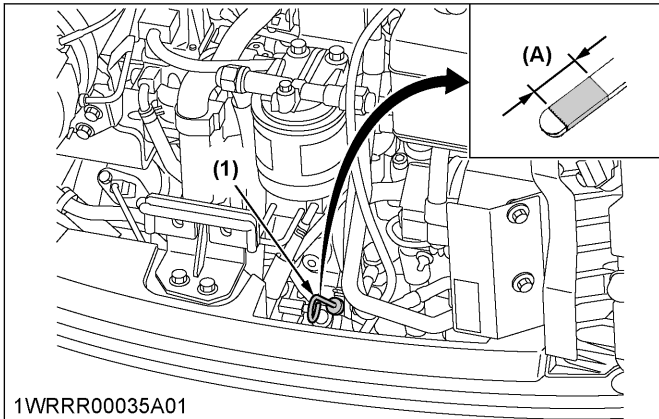

(1) Engine oil dipstick (A) Required oil level range

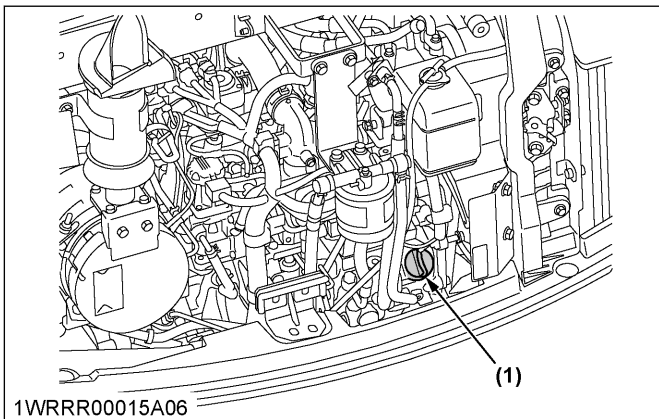

(1) Oil filling port

4. Add oil if necessary.

Engine oil volume (with engine oil filter)	7.0 L (1.8 U.S.gals)
---	----------------------

5. Checking the hydraulic oil level

WARNING

To avoid personal injury or death:

- Stop the engine before checking the oil level.
- There is a risk of being injured by hot pressurized hydraulic oil. Make sure that the oil has cooled down sufficiently, and then release

the pressure in the tank before loosening the hydraulic oil filling plug.

IMPORTANT :

- Before filling with oil, wipe away all sand and dust from around the oil port. Make sure to use an identical type of hydraulic fluid.
- The machine has been filled with hydraulic fluid before delivery. Do not mix different oils. (See **RECOMMENDED OILS AND FUELS** on page 161.)

1. Park the machine on a firm, flat and level surface, lower the attachments and dozer blade to the ground, and stop the engine.

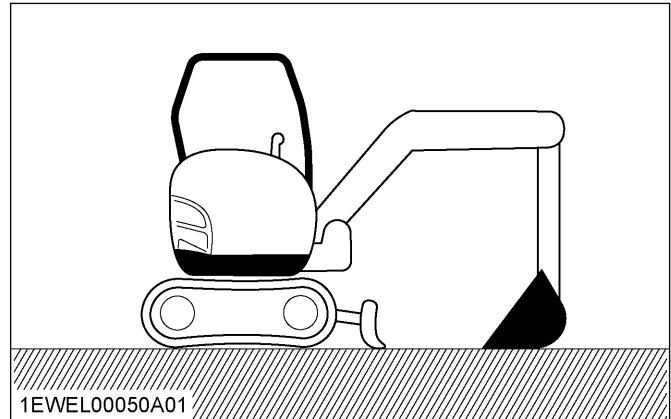

2. Check the oil level, making sure that it lies at the center of the gauge at normal temperature (10 °C to 30 °C, 50 °F to 86 °F). Enough oil is present when the oil level is at the center mark.

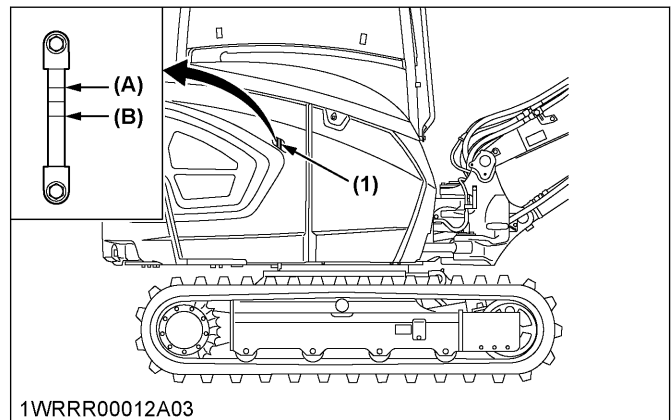

(1) Gauge

(A) Upper limit
(B) Lower limit

- If the oil level is below the center mark, push the button on the breather filter to release the pressure in the tank, loosen the hydraulic oil filling plug, and then fill the tank up with oil at the oil filling port.
(For details on releasing pressure trapped in the hydraulic tank see Replacing the hydraulic oil tank breather filter on page 139.)

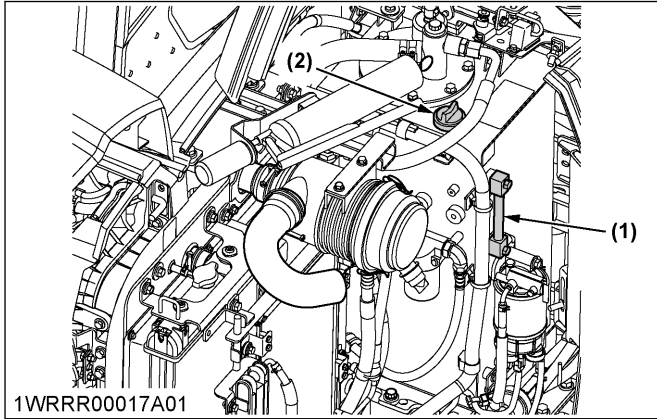

(1) Gauge
(2) Oil filling plug

6. Checking the water separator

IMPORTANT :

- As water is collected in the cup, the red float rises up.
Once the float has reached the specified line, immediately drain the water separator.
- When reattaching the water separator, make sure that no dust or dirt get into the cup or other surrounding parts.
- Purge the fuel system before restarting the machine.
(See PURGING THE FUEL SYSTEM on page 150.)

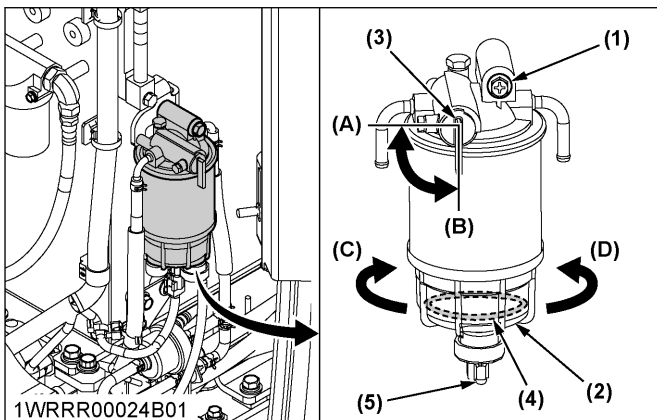

(1) Screw
(2) Cup
(3) Shutoff-valve
(4) Float
(5) Drain plug
(A) OFF
(B) ON
(C) Loosen
(D) Tighten

As separated water is collected in the cup, the red float rises up. Regularly check the water level and drain the water as necessary.

NOTE :

- Water and dirt contained in the fuel settle in the water separator. When deposits of such foreign substances build up, clean the water separator.**

- Open the side cover.
(See Opening and closing the side cover on page 119.)
- Check the water level. If the float has reached the line, drain the water as follows:
 - Set the water separator handle to the [OFF] position so that no fuel can run out.
 - Loosen and remove the cup.
 - Pour out all of the water in the cup.
 - Reattach the cup, tighten the retainer ring, and set the water separator handle to the [ON] position.
- Close the side cover.

7. Checking the radiator and oil cooler

WARNING

To avoid personal injury or death:

- Always stop the engine before checking the radiator and the oil cooler.
- Wear eye protection when cleaning with compressed air.
- Replace the hydraulic hoses and all water hoses every 2 years.
(For details on replacing hydraulic hoses, see PERIODIC REPLACEMENT OF PARTS on page 159.)
- Inspect the hydraulic hoses and all water hoses daily.

Have the excavator repaired immediately if any of the following issues are discovered.

Such issues may cause burns or injury. They may also cause engine failure, serious engine damage, hydraulic system failure, or serious hydraulic system damage.

- Scratches, cracks, or swelling in hydraulic hoses or water hoses.
- Leakage at joints or connecting points.
- Missing or damaged protective sleeve or grommet.
- Loose mounting bolt, damaged bracket.

(For details on inspecting hydraulic hoses, see PERIODIC REPLACEMENT OF PARTS on page 159.)

- Do not touch hydraulic hoses or water hoses with your hand. You may get burned.

IMPORTANT :

- Radiator, oil cooler fins and ribs must be clean in order to avoid overheating the engine and to allow free flow of air through the cooling elements.
- Pressure of compressed air must be under 205 kPa (2.1 kgf/cm², 30 psi)

Checking for dirt and cleaning

1. Check to see if the fins are clogged with dirt
2. If the fins are clogged, remove the dirt, making sure to always wear eye protection when cleaning:

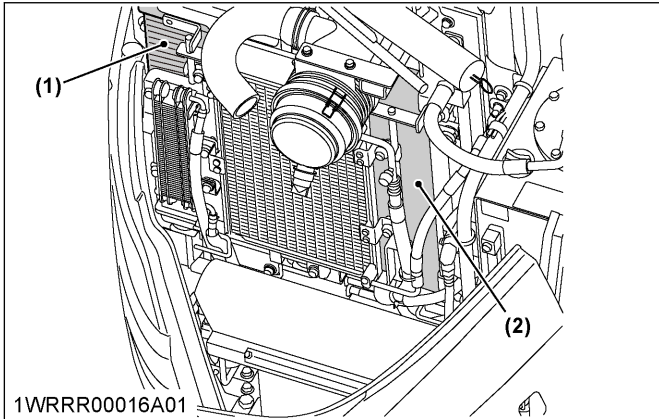

- (1) Coolant radiator
- (2) Oil cooler

Checking the rubber hoses and clamps

1. Check the rubber hoses for damage and replace if cracked or old.
2. If hose clamps are loose or water leaks, tighten the bands securely.

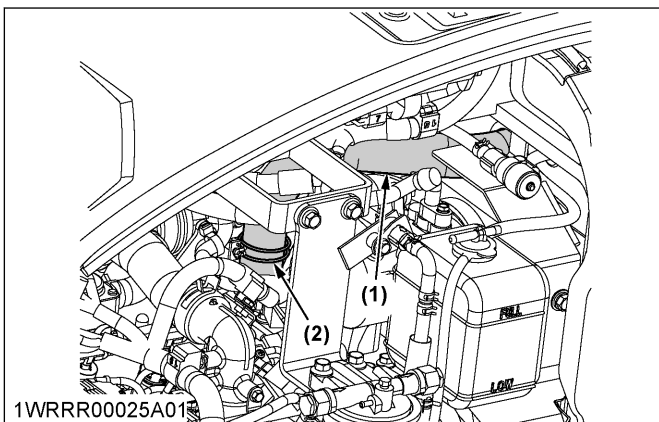

- (1) Rubber hose
- (2) Hose clamp

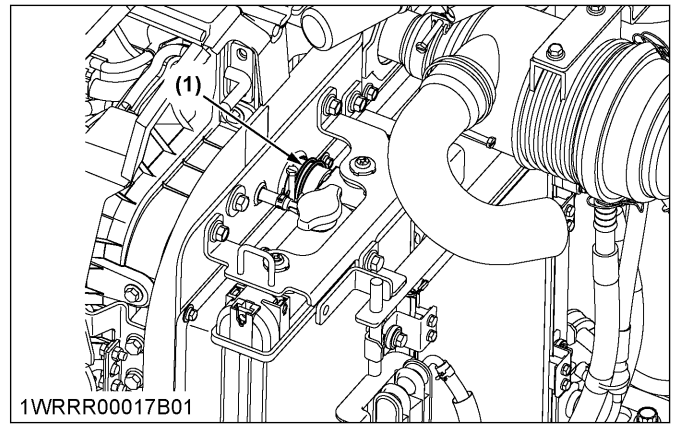

- (1) Hose clamp

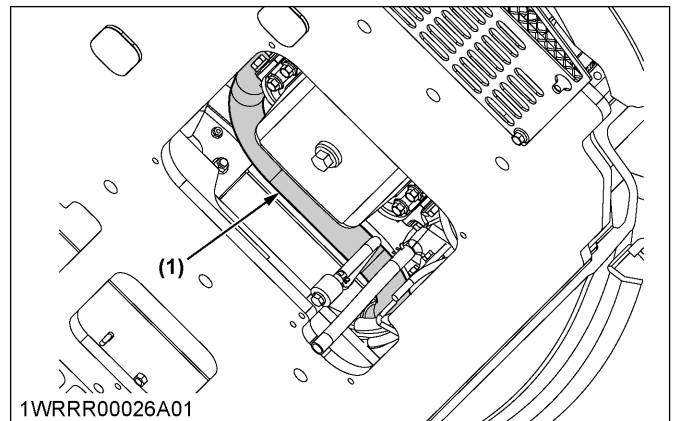

- (1) Rubber hose

8. Checking the ROPS

⚠ WARNING

To avoid personal injury or death:

- Never remove the ROPS.

1. Check all of the bolts to make sure that none of them have come loose.
2. Check the ROPS for damage. If it is found to be damaged or deformed, it needs to be replaced. Contact your local Kubota dealer.

9. Checking the filter indicator

1. Check the filter indicator.
2. If the red bar on the filter indicator has reached the service level, clean the air filter element immediately.
(See Inspecting and cleaning the air filter element on page 133.)

- After cleaning, reset the red bar by pressing the reset button.

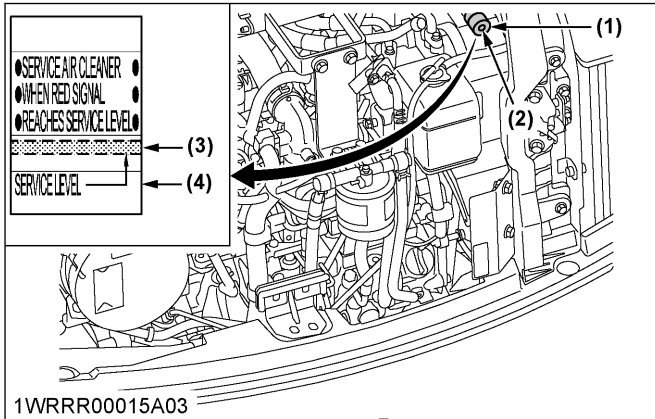

- 1WRRR00015A03
- Filter indicator
 - Reset button
 - Red bar
 - Service level

10. Checking the V-belt

! WARNING

To avoid personal injury or death:

- Stop the engine before checking the V-belt.

Check the V-belt for cracks and proper tension. (See Adjusting the V-belt tension on page 136.)

11. Checking the washer liquid

- Check the level of the washer liquid in the tank.
- Top up the washer liquid as necessary.

NOTE :

- If the window washer is switched on while the washer liquid tank is empty, the motor may get damaged. Always keep the tank filled.

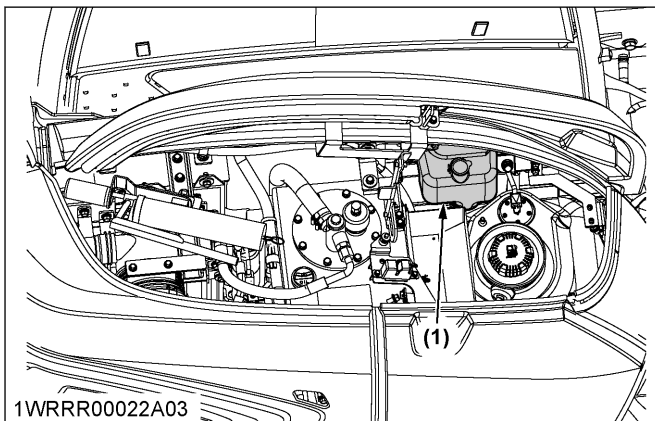

- 1WRRR00022A03
- Washer liquid tank

12. Checking and cleaning the engine and electrical wiring

! WARNING

To avoid personal injury or death:

- Always stop the engine before cleaning the wiring, cables and engine.

- Check whether flammable substances have gathered on the battery, cables, wiring, muffler, or engine, and thoroughly remove any such substances.
- Check the electrical circuitry for disconnections, shorts, or loose terminals.

13. Checking the evacuator valve

- Open the evacuator valve.
- Get rid of large particles of dust and dirt.

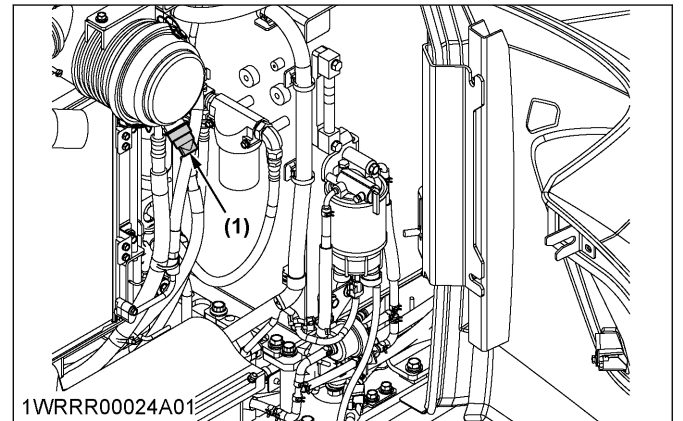

- 1WRRR00024A01
- Evacuator valve

NOTE :

- If the evacuator valve is missing or damaged, the air cleaner does not function properly. Accordingly, its element's service life will get shorter.

14. Checking the diesel particulate filter (DPF) muffler

! WARNING

To avoid personal injury or death:

- Before checking or cleaning the DPF muffler, stop the engine and wait long enough until it is cooled down.

1. Check to make sure that nothing flammable is deposited around the DPF muffler. Otherwise a fire may result.

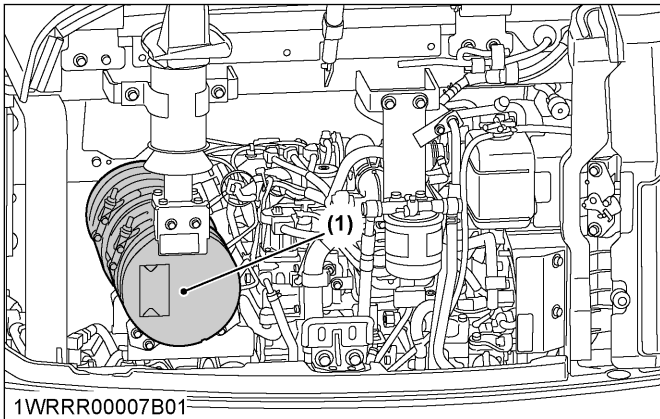

(1) DPF muffler

15. Checking for exhaust leaks

1. Check to make sure that there are no exhaust leaks.

16. Checking the electrical equipment

1. Check the function of the working light.

17. Checking the seat belt

1. Check the seat belt, the socket, and the metal fittings for dirt or damage. If any of them are found to be damaged or deformed, they need to be replaced. Contact your local Kubota dealer.

18. Greasing the front attachments

WARNING

To avoid personal injury or death:

- First, lower all attachments on the ground and stop the engine.
- While greasing, take care not to step on the bucket teeth.

IMPORTANT :

- When doing excavation work in water, generously grease the following points. Grease once again after finishing the work.

1. Grease the marked grease fittings shown in the following illustrations.

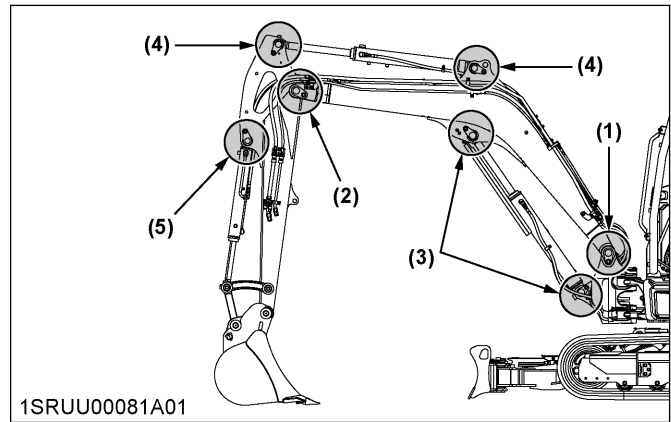

- (1) Boom bottom linkage
- (2) Arm bottom linkage
- (3) Boom cylinder boss
- (4) Arm cylinder boss
- (5) Bucket cylinder boss

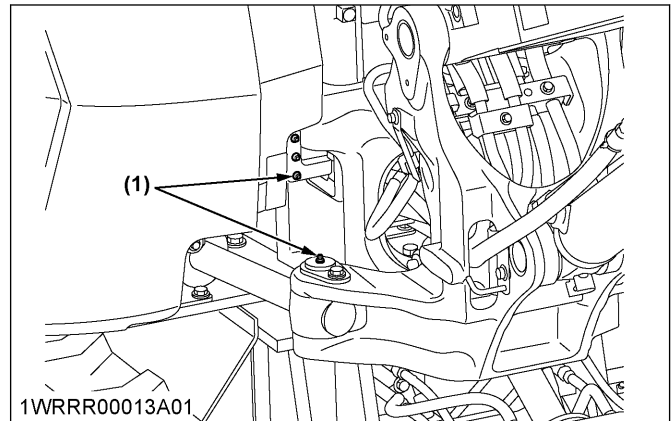

- (1) Swing cylinder boss

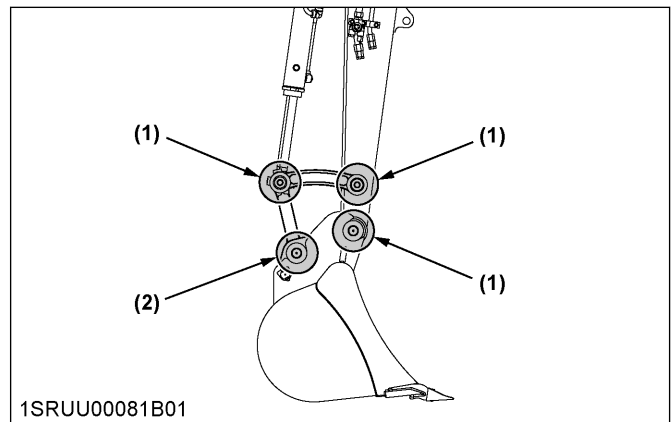

- (1) Bucket link pin
- (2) Fixing pin between arm and bucket

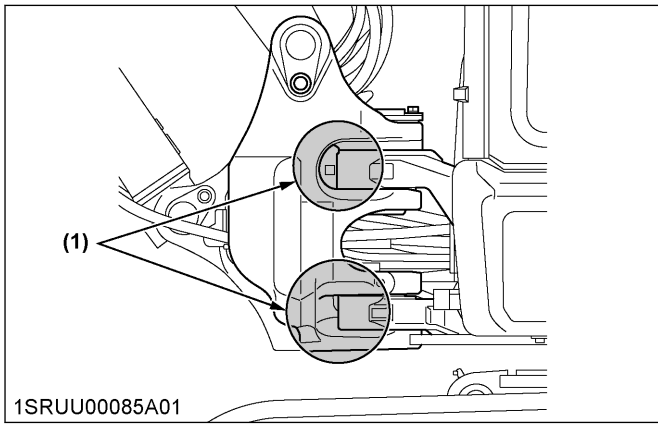

1SRUU00085A01

(1) Boom swing fulcrum

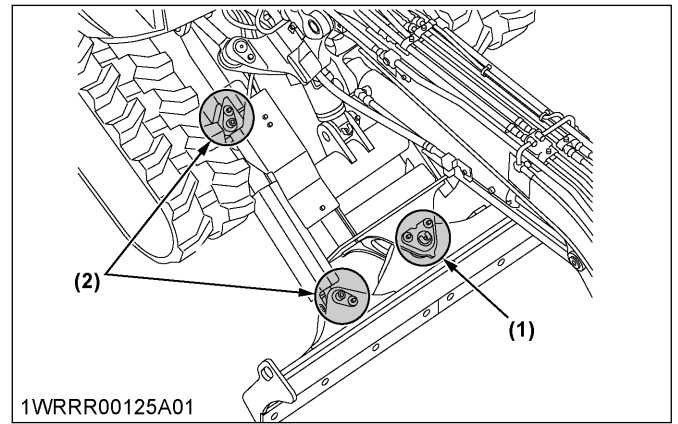

1WRRR00125A01

(1) Angle pin
(2) Angle cylinder boss

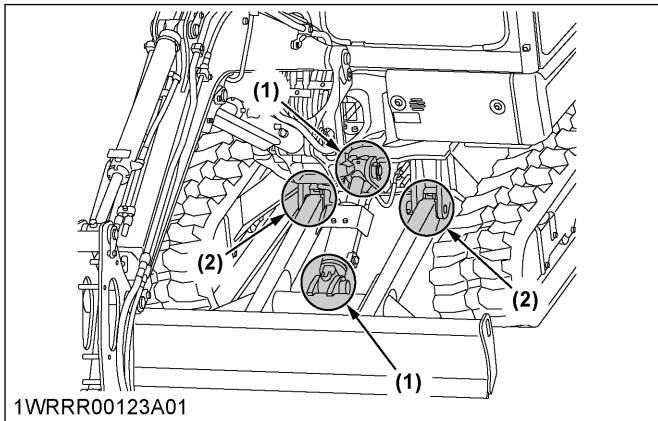

1WRRR00123A01

(1) Dozer cylinder boss
(2) Dozer linkage pin

[6-in-1 blade type]

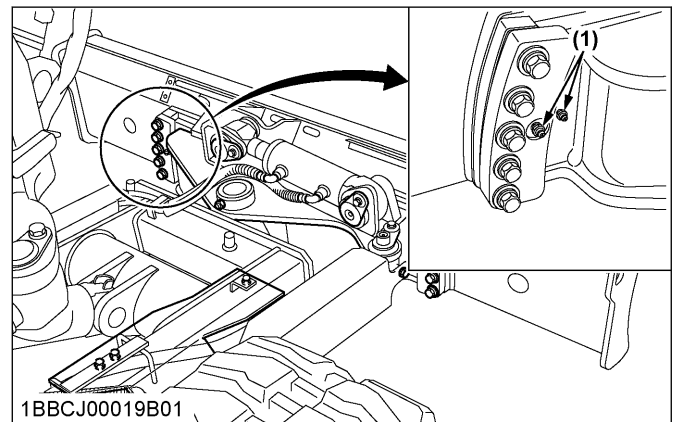

1BBCJ00019B01

(1) Dozer sliding plate

[Angle blade type]

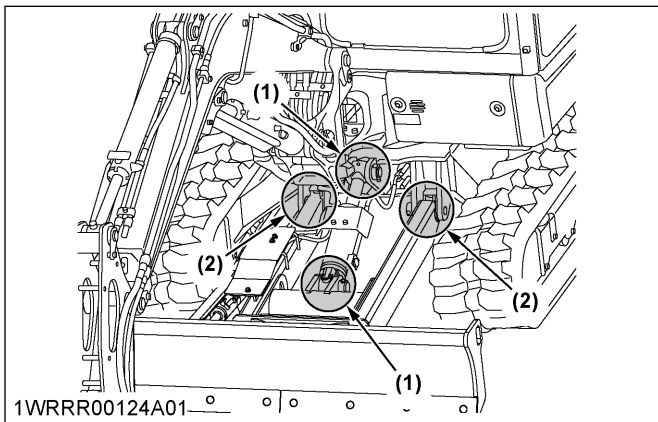

1WRRR00124A01

(1) Dozer cylinder boss
(2) Dozer linkage pin

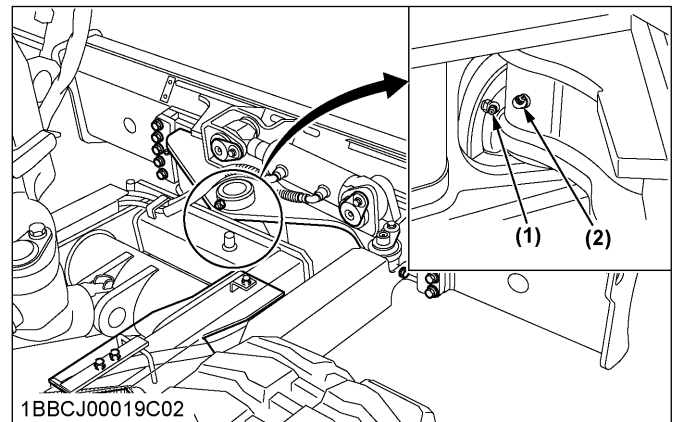

1BBCJ00019C02

(1) Tilt fulcrum
(2) Angle pin

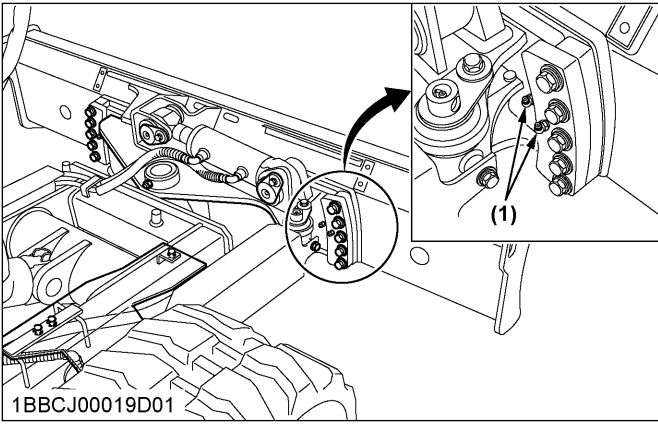

(1) Dozer sliding plate

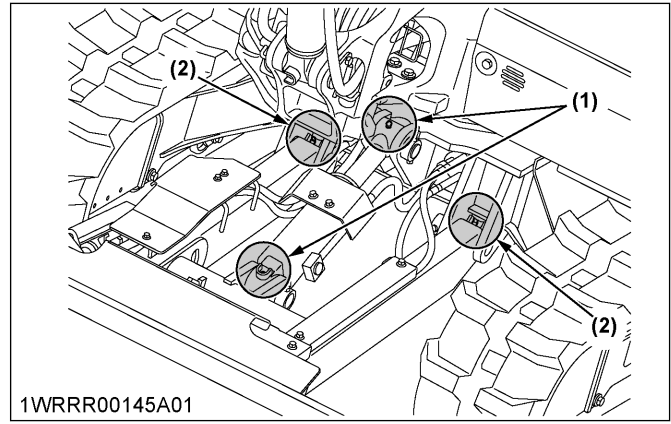

(1) Dozer cylinder boss
(2) Dozer linkage pin

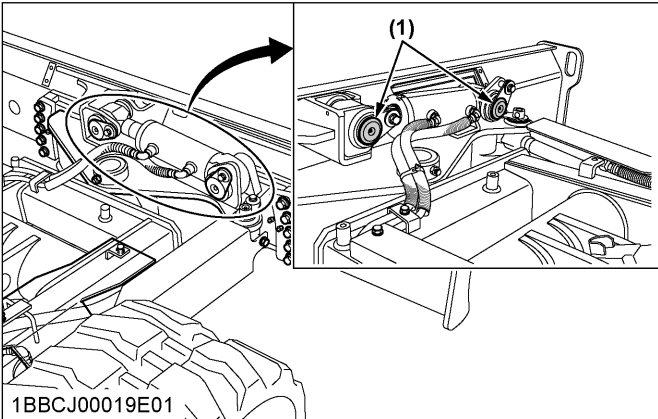

(1) Tilt cylinder pin

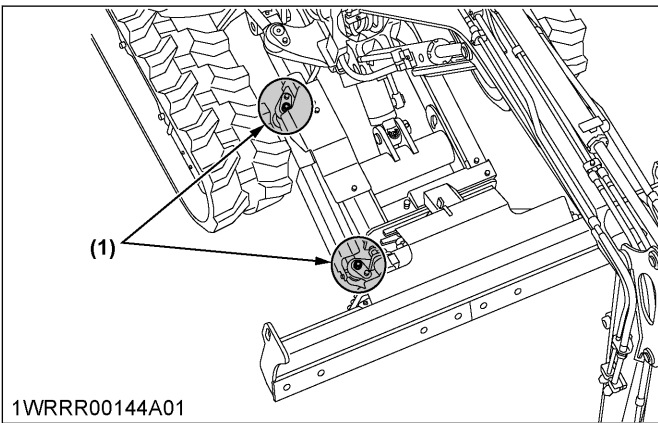

(1) Angle cylinder boss

REGULAR CHECKS AND MAINTENANCE WORK

⚠ WARNING
To avoid personal injury or death:

- When operating, keep hands and body inside the ROPS and OPG (top guard level I).
- Do not touch the control levers and the pedals from outside the ROPS and OPG (top guard level I) while the engine is running.

EVERY 50 SERVICE HOURS

1. Draining water from the fuel tank

⚠ WARNING
To avoid personal injury or death:

- Before draining water from the fuel tank, stop the engine.
- Do not smoke during the inspection.

1. Open the side cover.
(See Opening and closing the side cover on page 119.)
2. Open the drain shutoff-valve.

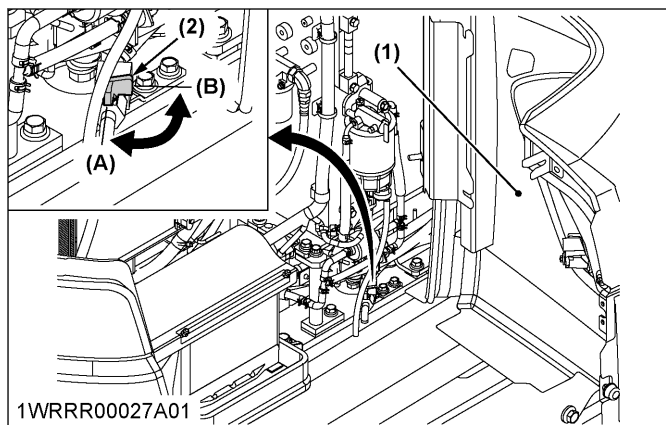

(1) Side cover (A) Open
 (2) Drain shutoff-valve (B) Close

2. Cleaning the water separator

- IMPORTANT :**
- In reattaching the water separator, be careful to keep off dust and dirt.
 - Purge the fuel system before restarting the machine.
(See PURGING THE FUEL SYSTEM on page 150.)

Water and dirt contained in fuel will settle in the water separator. When deposits of such foreign substances build up, drain and clean the water separator as follows.

Draining

1. Set the shutoff-valve to the [OFF] position.
2. Loosen the top screw first and then loosen the drain plug to let the foreign substances out of the separator.
3. Air-bleed the fuel system.
4. Set the shutoff-valve to the [ON] position.

Cleaning

1. Set the shutoff-valve to the [OFF] position.
2. Loosen and remove the cup properly, and clean its inside with diesel fuel.
3. Tighten up the cup properly.
4. Set the shutoff-valve to the [ON] position.

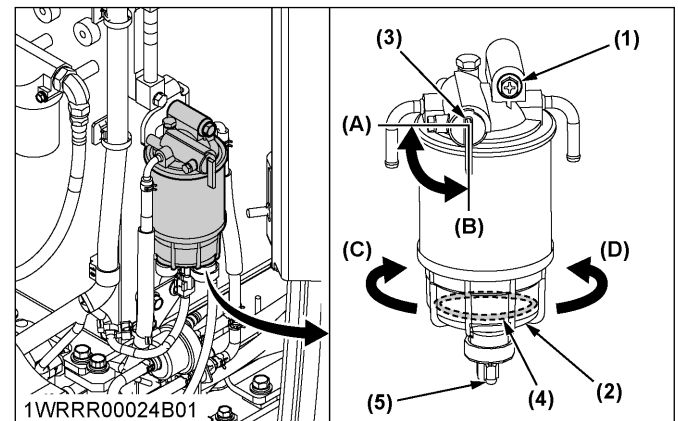

(1) Screw (A) OFF
 (2) Cup (B) ON
 (3) Shutoff-valve (C) Loosen
 (4) Float (D) Tighten
 (5) Drain plug

3. Checking the battery condition

⚠ DANGER
To avoid the possibility of a battery explosion:
 For the refillable type battery, observe the following instructions:

- Do not use or charge the refillable type battery if the fluid level is below the [LOWER] (lower limit level) mark. Otherwise, the battery component parts may prematurely deteriorate, which may shorten the battery's service life or cause an explosion. Check the fluid level regularly and add distilled water as required so

that the fluid level is between the [UPPER] and [LOWER] levels.

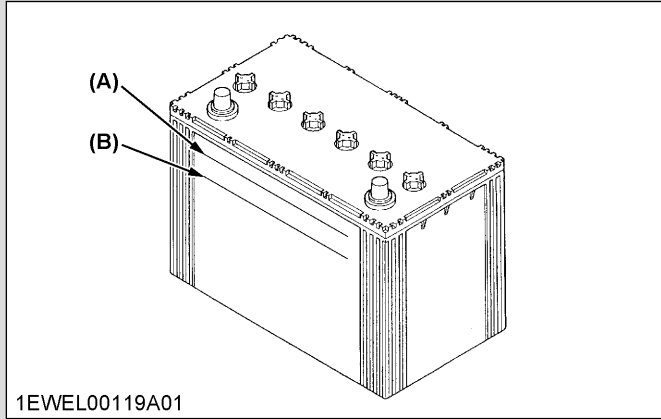

(A) UPPER
(B) LOWER

WARNING

To avoid personal injury or death:

- Never remove the vent caps while the engine is running.
- Keep electrolyte away from eyes, hands, and clothes. If you are splattered with it, immediately wash it away completely with water and get medical attention.
- Wear eye protection and rubber gloves when working around the battery.
- Before inspecting or dismantling the battery, turn the starter switch to the [STOP] position and disconnect the ground cable.
- When removing the battery, always disconnect the negative ground cable first. When installing a battery, always connect the ground cable last. This prevents a possible explosion caused by sparks.
- Always wear eye protection when working with the battery.

NOTE :

- Mishandling the battery shortens the service life.
- The original battery is maintenance-free, but needs some servicing.
- If the battery charge is low, it will be difficult to start the engine and the lights will be dim. It is important to check the battery periodically.

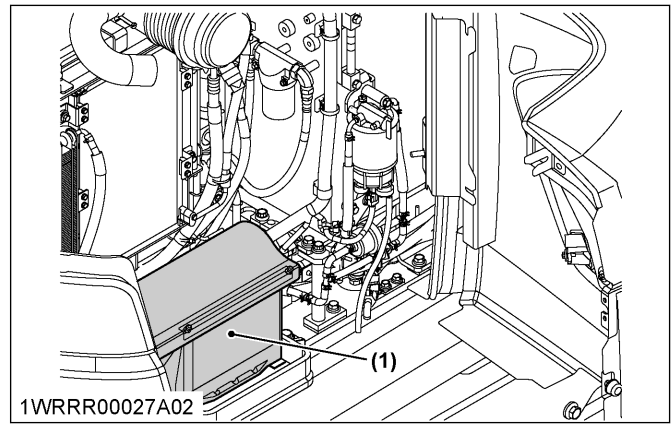

(1) Battery

1. Open the side cover.
(See Opening and closing the side cover on page 119.)
2. Check the battery condition by reading the indicator.

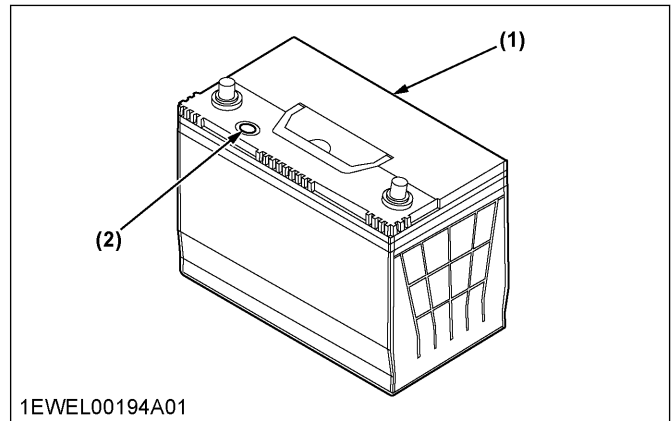

(1) Battery
(2) Indicator

3. Refer to the following table, and charge the battery if necessary.

State of indicator display	
Green	Specific gravity of electrolyte and quality of electrolyte are both in good condition.
Black	The battery needs charging.
White	The battery needs replacing.

NOTE :

- The factory-installed is a non-refillable type battery. If the indicator turns white, do not quick-charge the battery but replace it with a new one.

3.1 Charging the battery

WARNING

To avoid personal injury or death:

- When the battery is being activated, hydrogen and oxygen gases in the battery are extremely explosive. Keep open sparks and flames away from the battery at all times, especially when charging the battery.
- When charging battery, make sure that battery vent plugs are secured.
- When disconnecting the cable from the battery, start with the negative terminal first. When connecting the cable to the battery, start with the positive terminal first.
- Do not check battery charge by placing a metal object across the terminals. Use a voltmeter or hydrometer.

IMPORTANT :

- Make sure that each electrolyte level is to the bottom of vent wells. If necessary, add distilled water in a well-ventilated area.
- The water in the electrolyte evaporates during recharging. Liquid shortage damages the battery. Excess liquid spillage damages the machine.

NOTE :

- A boost charge is only for emergencies. It will partially charge the battery at a high rate and in a short time. When using a boost-charged battery, it is necessary to recharge the battery as early as possible. Failure to do this will shorten the battery's service life.
 - When exchanging an old battery for a new one, use a battery of equal specification.
1. To slow-charge the battery, connect the battery positive terminal to the charge positive terminal and the negative to the negative.
 2. Charge the battery in the standard fashion until the specific gravity of electrolyte falls between 1.27 and 1.29, meaning that the charge is complete.

4. Greasing the swivel bearing teeth

1. Pump grease with the grease gun through the grease fitting.
2. Grease the fitting at each 90° (1.58 rad) position of the swivel frame.

NOTE :

- Fill with approximately 50 g of grease, meaning approximately 20 to 30 pumps with the grease gun at each position.
- Distribute the grease over the teeth.

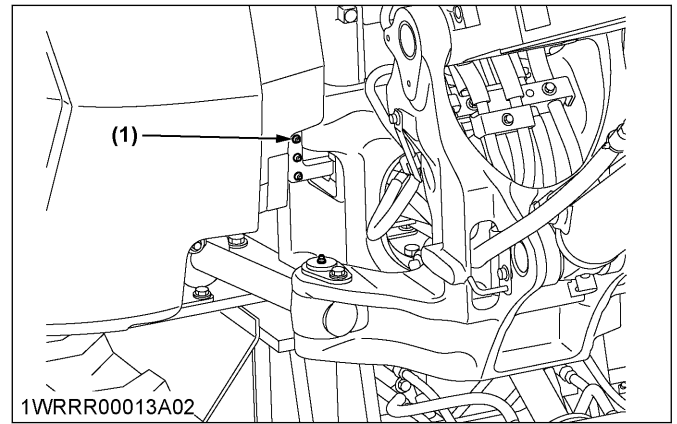

(1) Grease fitting (for swivel bearing teeth)

5. Checking the tracks

1. Check the track tension every 50 hours. (See ADJUSTING THE TRACKS on page 150.)

EVERY 150 SERVICE HOURS

Carry out all the 50 hours servicings at the same time.

1. Cleaning the air conditioner filter**⚠ WARNING**

To avoid personal injury:

- Wear eye protection.

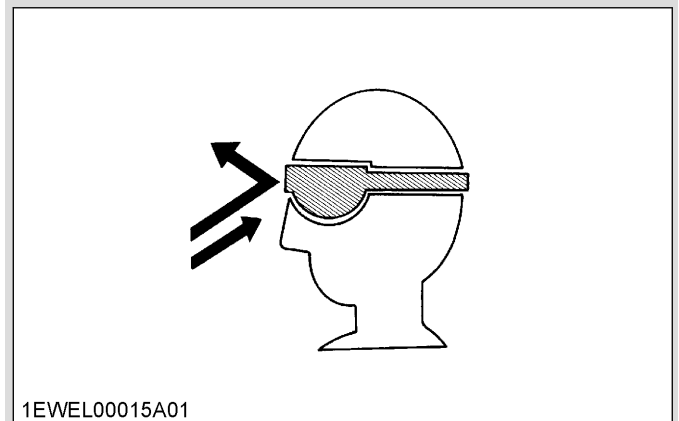

1EWEL00015A01

1. Open the cover under the operator's seat.
2. Remove the thumbscrew and the plate.

3. Remove the air conditioner filter.

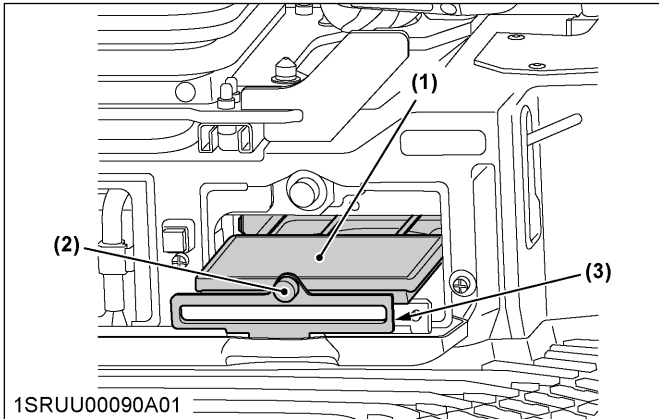

- (1) Air conditioner filter
- (2) Thumbscrew
- (3) Plate

4. For normal use, blow air from the opposite direction to the filter's normal air flow.

Air pressure	205 kPa (2.1 kgf/cm ² , 30 psi) or less
--------------	--

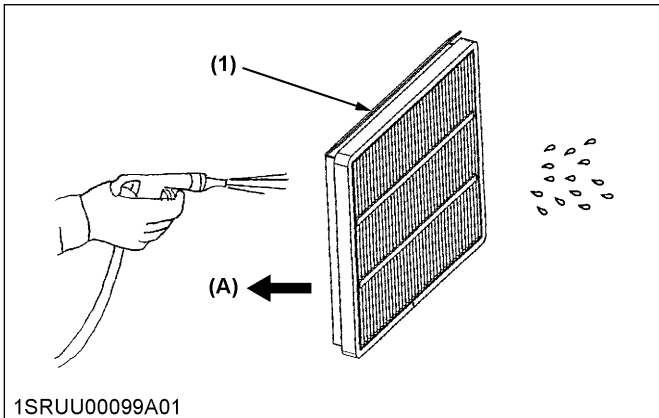

- (1) Air conditioner filter
- (A) Air conditioner airflow

IMPORTANT :

- Do not hit the filter. If the filter becomes deformed, dust may enter the air conditioner, which may cause damage and malfunction.
- Set the filter with the cushion facing upward and the V-flap facing outward. Incorrect setting shortens the filter's service life.

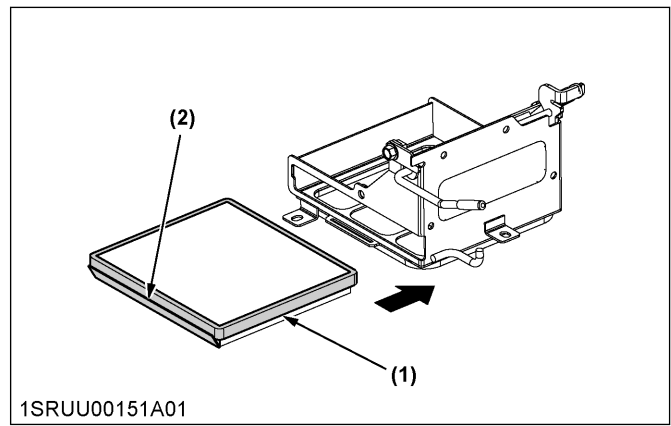

- (1) Cushion
- (2) V-flap

NOTE :

- If the filter is very dirty, replace the Air conditioner filter.

EVERY 200 SERVICE HOURS

Carry out all the 50 and 100 hours servicings at the same time.

1. Checking the radiator hoses and clamps

Check the radiator hoses and clamps every 200 hours or every 6 months, whichever comes first.

! WARNING
 To avoid personal injury or death:

- Wait long enough for the radiator coolant to cool down.

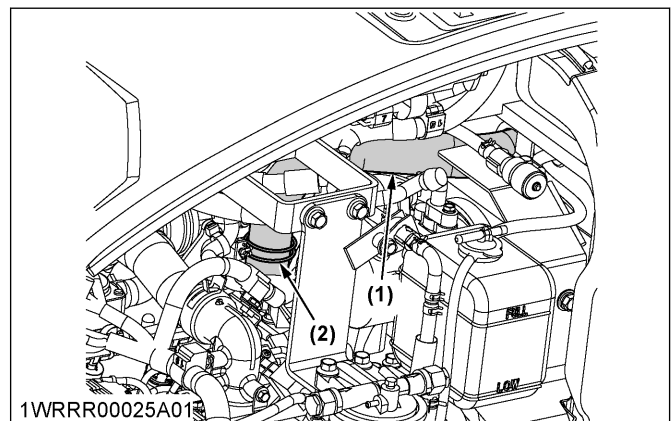

- (1) Rubber hose
- (2) Hose clamp

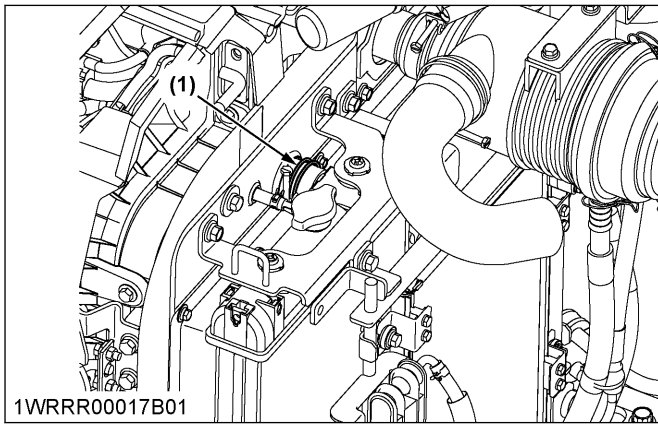

(1) Hose clamp

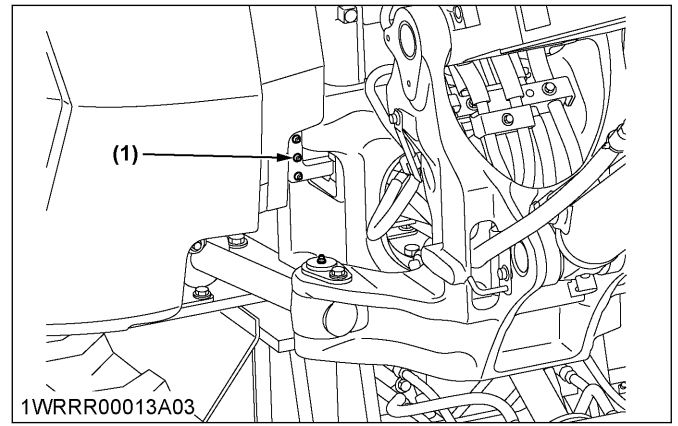

(1) Grease fitting

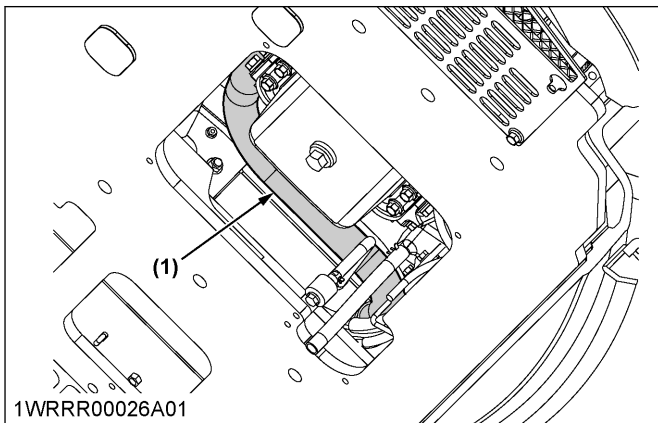

(1) Rubber hose

1. Check the coolant hoses for proper connection.
2. If the hose clamps become loose or if coolant leaks, tighten the hose clamps properly.
3. If the radiator hoses become swollen, worn out, or cracked, they must be replaced and the hose clamps must be tightened again properly.

2. Greasing the swivel bearing

1. Pump grease with a grease gun through the grease fitting indicated in the following illustration.
2. Grease at each 90° (1.58 rad) position of the swivel frame.

NOTE :

- Apply 5 shots with a grease gun at each position.

3. Inspecting and cleaning the air filter element

⚠ WARNING

To avoid personal injury or death:

- Wear eye protection when cleaning the air filter element.

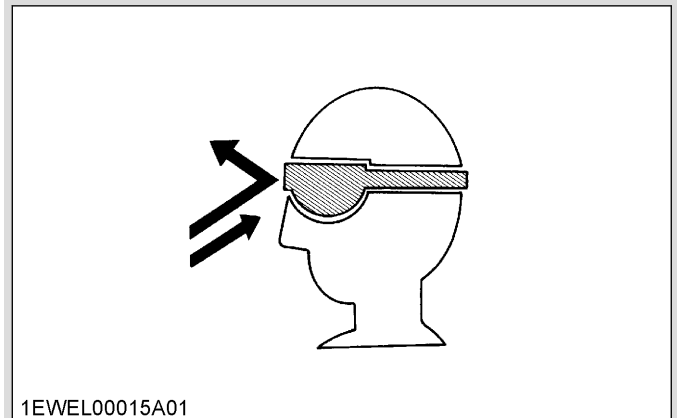

IMPORTANT :

- Should the machine be used in extremely dusty areas, the air filter element must be inspected and cleaned more frequently than instructed in the specified maintenance periods.
- The air filter has a dry element so keep it free from oil.
- Do not run the engine without the air filter.
- Clean the air cleaner element regularly or foreign matters will be accumulated, which will make the DPF longevity shorter than expected and the cleaning efficiency of the DPF will be reduced.

NOTE :

- The quickest and safest method of maintenance is to replace the paper cartridge with a new one.

1. Open the side cover and remove the dust cover.
(See Opening and closing the side cover on page 119.)
2. Remove only the outer element.

NOTE :

- Do not remove the inner element.

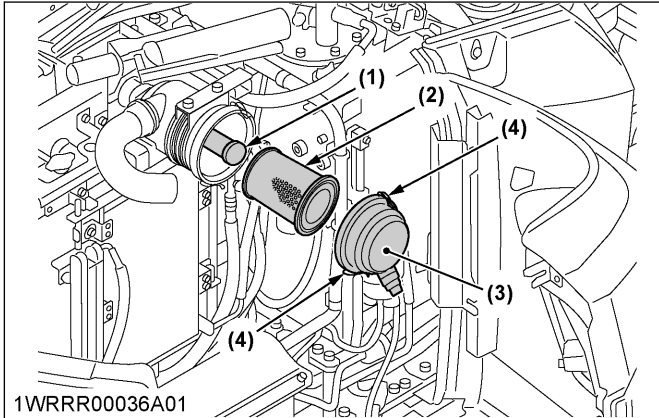

- (1) Inner element
 (2) Outer element
 (3) Dust cover
 (4) Clamp

3. Clean the interior of the element case as follows:
 - a. Blow off any dust attached to the outside of the cartridge using compressed air.
 - b. Blow the cartridge clean from inside to outside until the dust deposits are noticeably reduced.

Air pressure	205 kPa (2.1 kgf/cm ² , 30 psi) or less
--------------	--

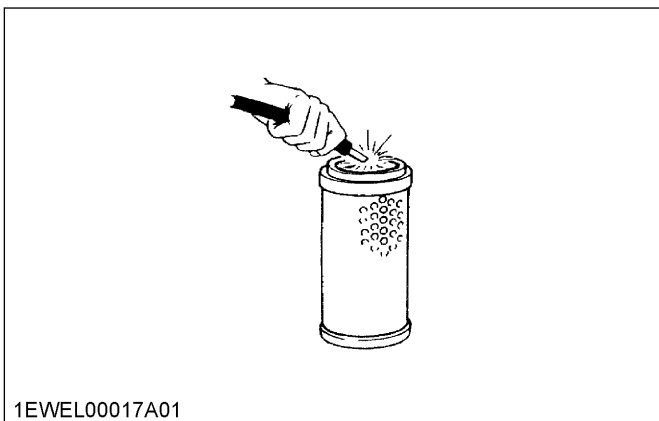

IMPORTANT :

- If the air suction is still inadequate, or the color of the exhaust gases is abnormal even after the cleaning, the air filter cartridge must be replaced.

4. Reassemble the element taking care to install the dust cover so that the "TOP" mark (arrow) points upwards.

4. Cleaning the evacuator valve

CAUTION

To avoid personal injury:

- Wear eye protection.
- While cleaning, foreign matters may drop out of the evacuator valve.

1. Open the side cover.
(See Opening and closing the side cover on page 119.)
2. Remove the dust cover.
3. From behind the dust cover, remove foreign matter from the evacuator valve.

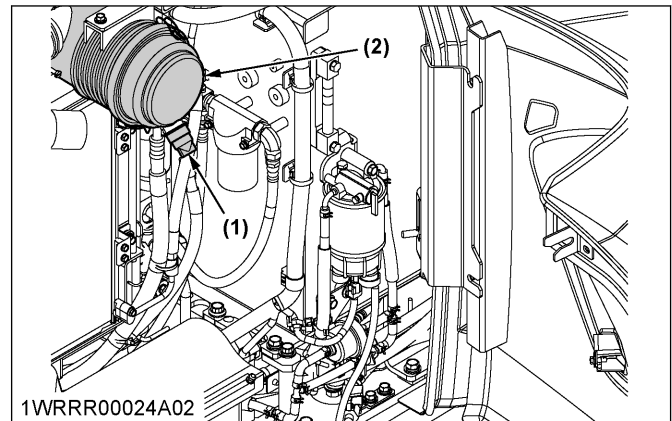

- (1) Evacuator valve
 (2) Dust cover

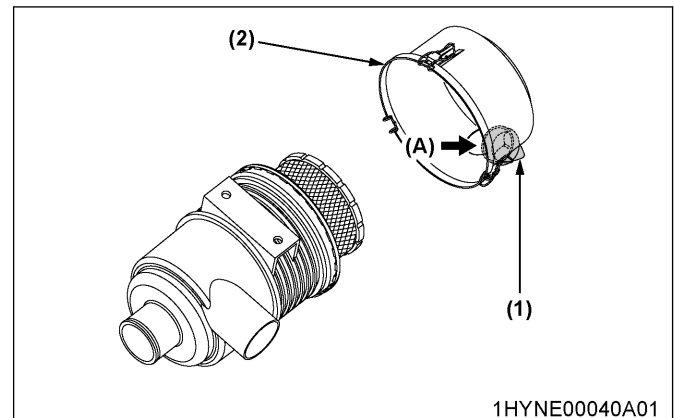

- (1) Evacuator valve
 (2) Dust cover
 (A) Clean from behind

IMPORTANT :

- Failure to clean the evacuator valve may shorten the air cleaner element's service life.

5. Checking the fuel line and intake air line

1. Check that all lines and hose clamps are tightened and not damaged.

2. If hoses and clamps are found worn or damaged, replace or repair them at once.

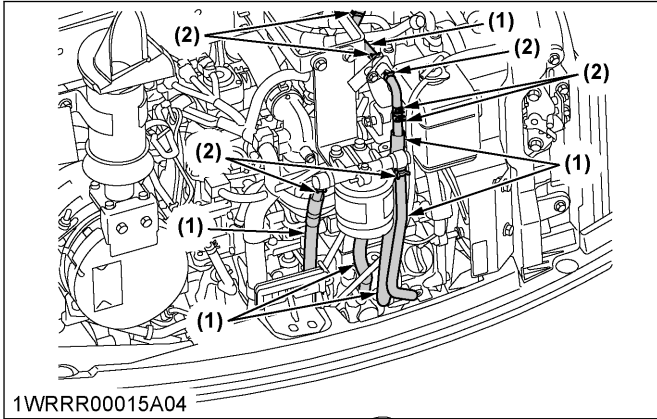

- (1) Fuel line
- (2) Clamp band

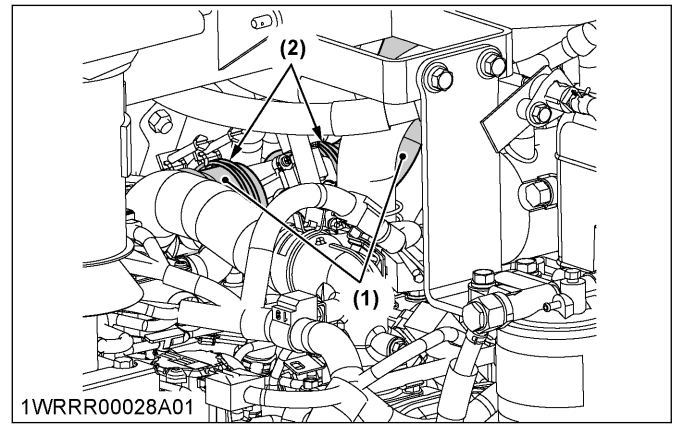

- (1) Hose
- (2) Hose clamp

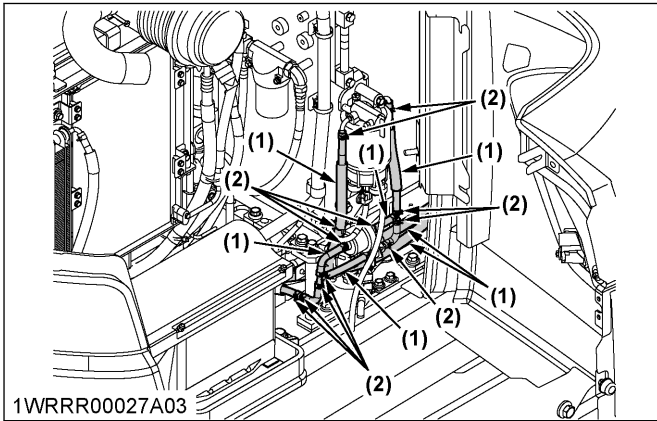

- (1) Fuel line
- (2) Clamp band

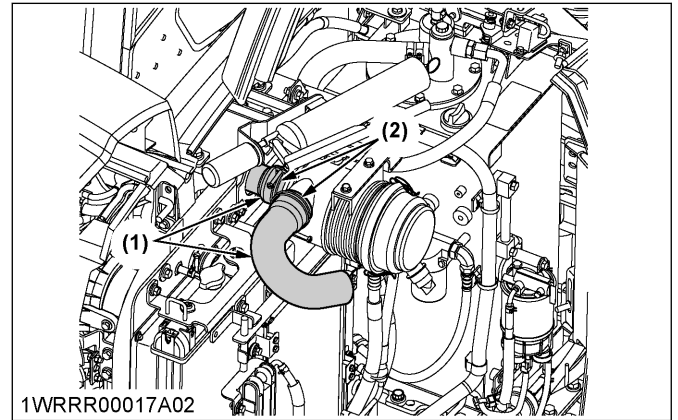

- (1) Hose
- (2) Hose clamp

6. Checking the air conditioner condenser

1. Check the air conditioner condenser to make sure it is clean from debris.

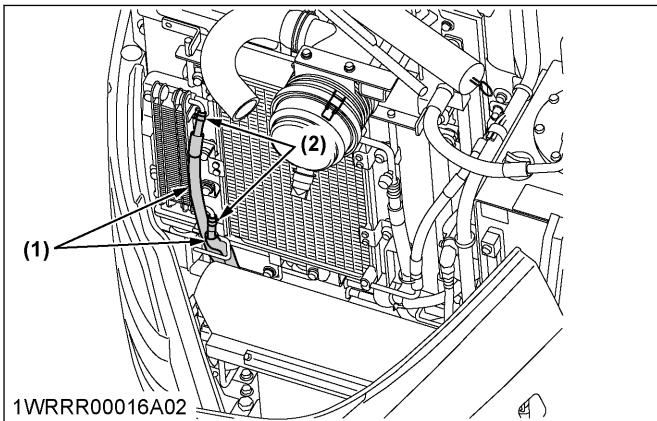

- (1) Fuel line
- (2) Clamp band

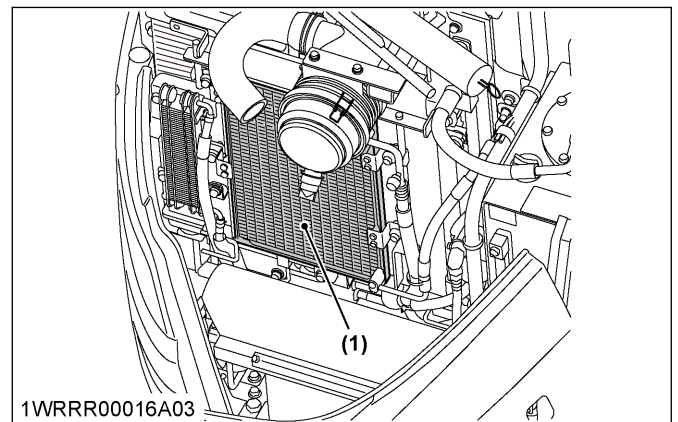

- (1) Air conditioner condenser

EVERY 250 SERVICE HOURS

Carry out all 50 hour servicings at the same time.

1. Adjusting the V-belt tension

WARNING

To avoid personal injury or death:

- First, stop the engine.
- After servicing, make sure to put back the belt cover in its original position.

1.1 Checking and adjusting the fan belt tension

IMPORTANT :

- If the engine is run with a loose fan belt, the belt could slip and cause insufficient battery charging. Check the fan belt tension regularly.
- If the fan belt breaks or jumps off, the indicator light for battery charge will light up. Stop the engine immediately.

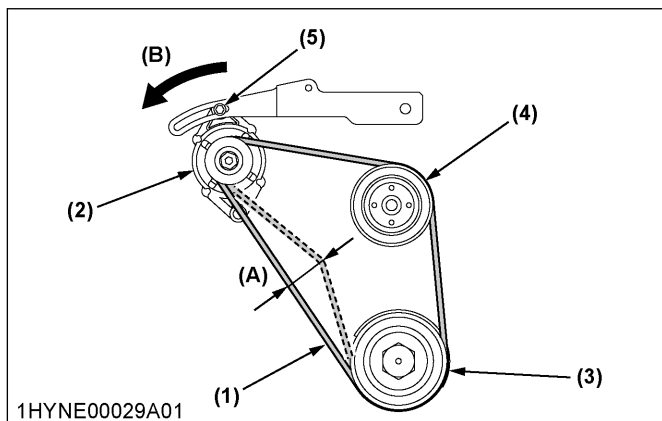

- (1) Fan belt (A) 7 mm to 9 mm (0.28 in. to 0.35 in.)
 (2) Alternator
 (3) Pulley (B) Tighten
 (4) Fan pulley
 (5) Bolt and nut

Checking

1. Press the fan belt in the middle, with a force of approximately 58.8 N to 68.6 N (6 kgf to 7 kgf, 13.2 lbf to 15.4 lbf).
The belt tension is correct if it deflects about 7 mm to 9 mm (0.28 in. to 0.35 in.).
2. Replace the fan belt if worn out, cracked or torn.

Adjusting

1. Loosen the bolt.
2. Shift the alternator in the direction shown by the arrow.

1.2 Checking and adjusting the air conditioner belt tension [CAB type only]

IMPORTANT :

- If the engine is run with a loose air-conditioner belt, the belt could slip and cause insufficient room temperature control. Check air-conditioner belt tension regularly.

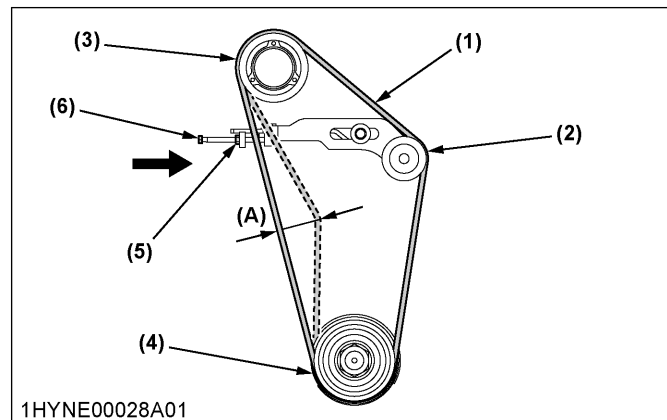

- (1) Air conditioner belt (A) 12 mm to 15 mm (0.47 in. to 0.59 in.)
 (2) Tension pulley
 (3) Air conditioner compressor
 (4) Pulley
 (5) Nut
 (6) Bolt

Checking

1. Press the air conditioner belt in the middle, with a force of approximately 58.8 N to 68.6 N (6 kgf to 7 kgf, 13.2 lbf to 15.4 lbf).
The belt tension is correct if it deflects about 12 mm to 15 mm (0.47 in. to 0.59 in.).
2. Replace the air conditioner belt if worn out, cracked or torn.

Adjusting

1. Loosen the nut and tighten the bolt.
2. Adjust the tension pulley in the direction shown in the illustration.

2. Greasing the pilot valve linkage

1. Apply grease to the pushrods, the contact surface of the plate, and the universal joint.

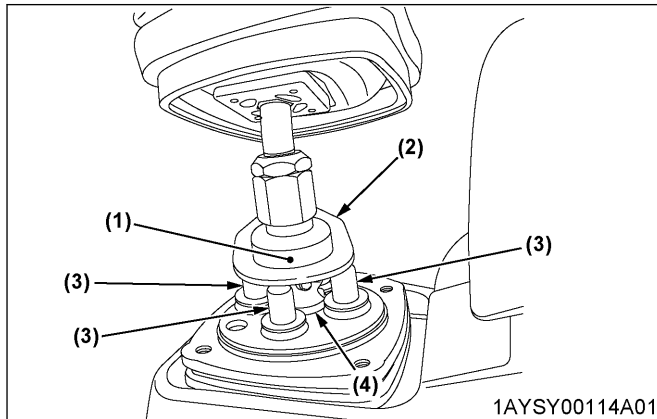

- (1) Pilot valve
- (2) Plate
- (3) Pushrod
- (4) Universal joint

NOTE :

- Apply grease to both the left and right pilot valves.

EVERY 500 SERVICE HOURS

Carry out all the 50 and 250 hour servicings at the same time.

1. Replacing the water separator filter element

1. Set the shutoff-valve to the [OFF] position.
2. Loosen and completely remove the cup.
3. Replace the filter element.
4. Check the condition of the O-ring and replace if necessary.
5. Fully tighten up the cup.
6. Set the shutoff-valve to the [ON] position.

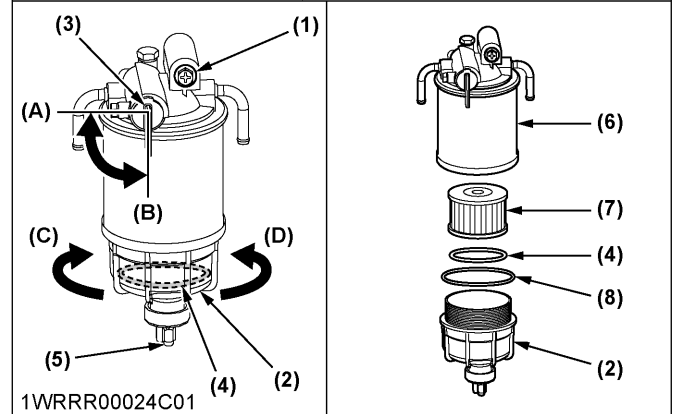
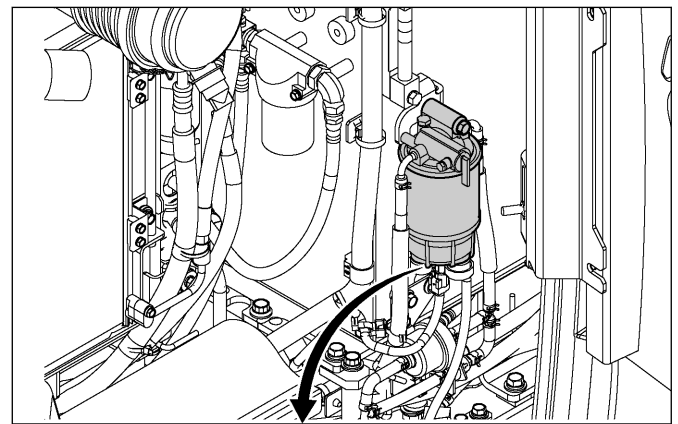

- (1) Screw
- (2) Cup
- (3) Shutoff-valve
- (4) Float
- (5) Drain plug
- (6) Head cover
- (7) Filter element
- (8) O-ring
- (A) OFF
- (B) ON
- (C) Loosen
- (D) Tighten

IMPORTANT :

- Users must take appropriate actions to insure fuel is not contaminated during the operation.
- If water or fuel is spilled, wipe around the water separator.

2. Changing the engine oil

Change the engine oil every 500 hours or every year, whichever comes first.

! WARNING

To avoid personal injury:

- First, stop the engine, and then wait long enough for the oil to cool down.

IMPORTANT :

- Regardless of the service hours, the engine oil change is due every year.
- Use engine oil API service classification CJ-4 or CK-4.

1. Remove the drain plug on the underside of the engine, and drain the oil completely.
2. Retighten the drain plug.

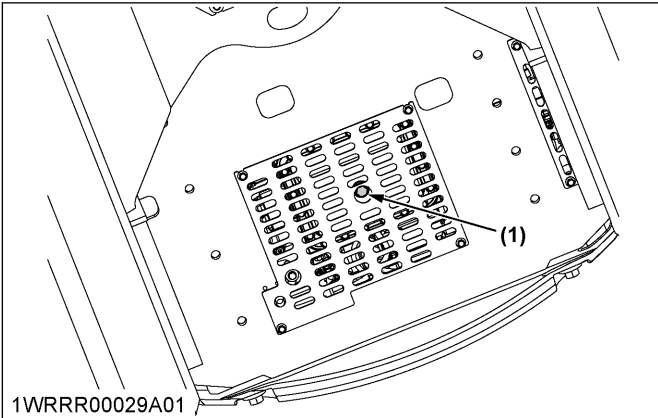

(1) Drain plug

3. Fill up with new oil through the filling port up to the specified level.

Engine oil volume (with engine oil filter)	7.0 L (1.8 U.S.gals)
--	----------------------

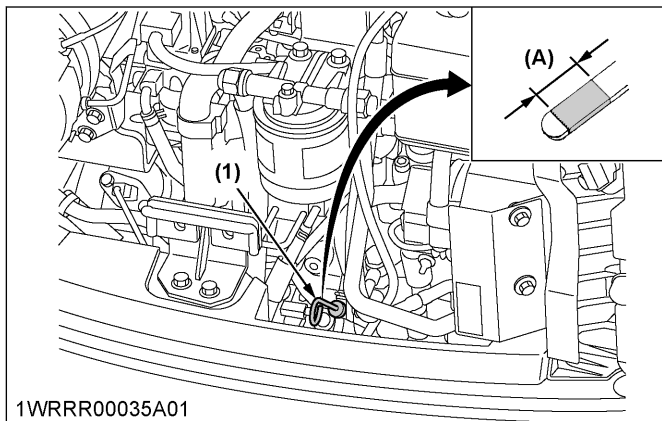

(1) Engine oil dipstick

(A) Required oil level range

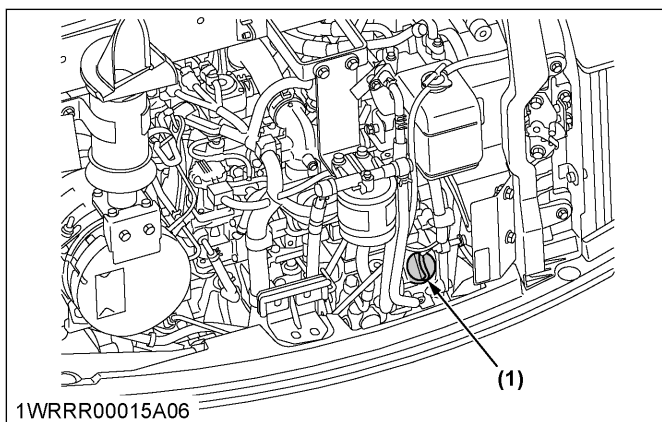

(1) Oil filling port

4. Let the engine idle for approximately 5 minutes.
5. Check the engine oil level by inserting the engine oil dipstick completely into the respective port opening and then pulling the dipstick out. If the oil level lies

between the two markings, do not add any additional oil.

3. Replacing the engine oil filter cartridge

Replace the engine oil filter cartridge at the same time as replacing the engine oil every 500 hours or every year, whichever comes first.

IMPORTANT :

- Always check the oil level after exchanging the filter.

1. Place an oil pan under the machine.

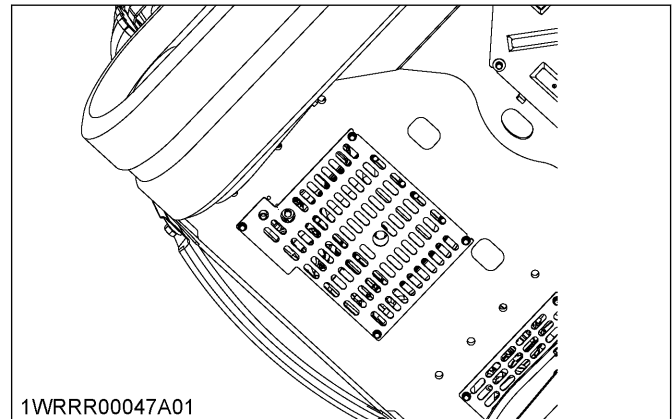

2. Remove the cartridge with the supplied filter wrench.

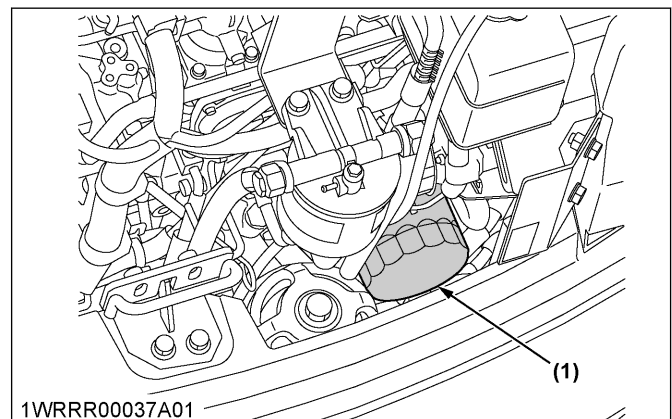

(1) Oil filter cartridge

3. Oil the O-ring of the new oil filter cartridge lightly. Then tighten the oil filter cartridge by hand.
4. Fill engine oil to the specified level.
5. Let the engine run for approximately 5 minutes and make sure that the engine oil indicator lamp does not light up.
6. Stop the engine.
7. As the engine oil level is reduced by the amount of the filter capacity after the engine is started, add oil as necessary.

4. Changing the drive unit oil

The first oil change is after 50 service hours.

CAUTION

To avoid personal injury:

- Lower all attachments to the ground, stop the engine before undertaking the oil change.

NOTE :

- The first oil change is after 50 hours.
- The normal oil change period is every 500 hours.
- Change the oil at least once a year.

1. Rotate the track so that the drain plug of the drive unit is in the bottom position.
2. Remove the drain plug to let the oil run out.
3. Screw in and tighten the drain plug again and fill gear oil through the oil filling port.

Gear oil volume	Approximately 0.65 L (0.2 U.S.gals)
-----------------	--

NOTE :

- Use prescribed gear oil SAE 90.

4. Fill oil until it overflows from the oil check port.

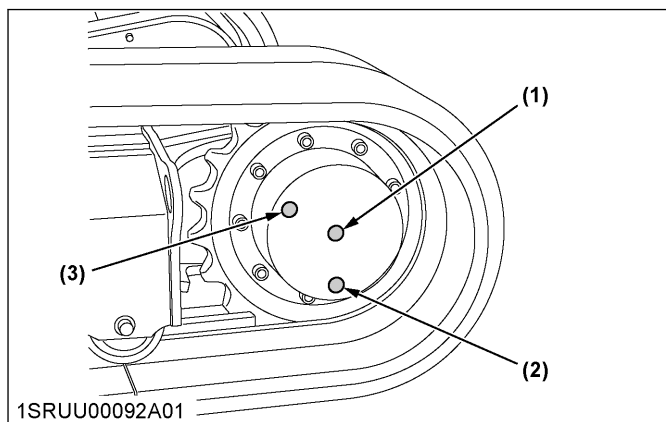

- (1) Oil check port
(2) Drain plug
(3) Oil filling port

5. Replacing the fuel filter cartridge

WARNING

To avoid personal injury or death:

- Keep away from fire.

1. Remove the filter with the filter wrench.
2. Apply a light film of fuel to the seal of the new filter and fix it tightly into position by hand.

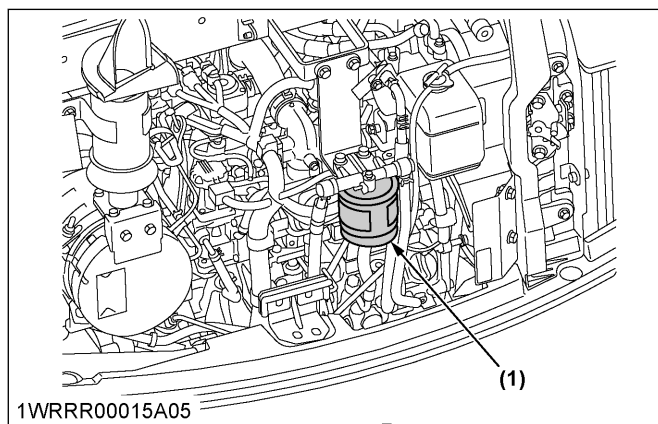

(1) Fuel filter cartridge

IMPORTANT :

- After replacing the filter, the fuel system must be purged of air.
 - Do not add any fuel into the new filter cartridge before installing it. Debris in fuel can damage the engine.
 - If you do not replace the fuel filter cartridge regularly, the cleaning efficiency of the DPF will be reduced and the DPF longevity will be shorter than expected.
 - Users must take appropriate actions to insure fuel is not contaminated during the operation.
- If fuel is spilled, wipe around the filter.

6. Replacing the hydraulic oil tank breather filter

WARNING

To avoid personal injury or death:

- There is a risk of being injured by hot pressurized hydraulic oil. Make sure that the oil has cooled down sufficiently, and then release the pressure before performing this service.

IMPORTANT :

- Maintain the utmost cleanliness when servicing the hydraulic system.

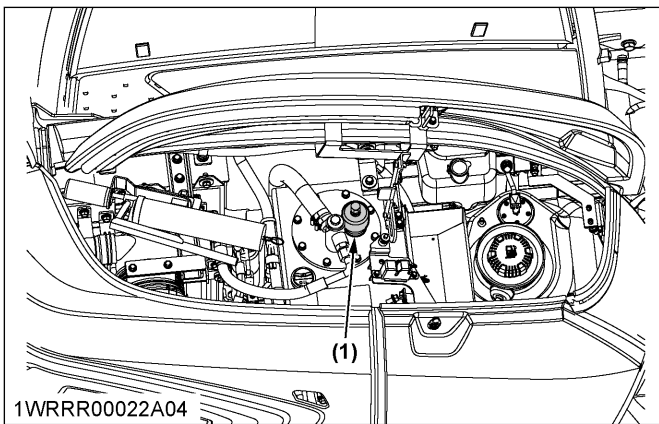

(1) Breather filter

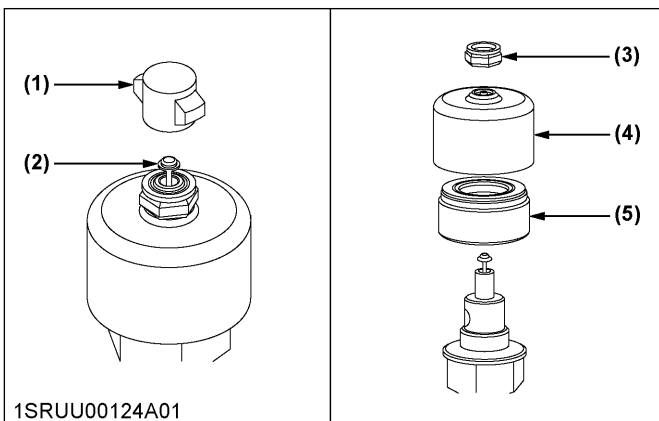

- (1) Cap nut
 (2) Button
 (3) Nut
 (4) Cover
 (5) Breather filter

1. Open the fuel tank cover.
(See Opening and closing the fuel tank cover on page 118.)
2. Unscrew the cap nut.
3. Push the button to release the pressure.
4. Unscrew the nut and remove the cover.
5. Take out the breather filter and replace it with a new one.

NOTE :

- **Dispose of cleaning cloths and the old filter element in accordance with applicable environmental protection regulations.**

6. Tighten the cover and the nut and install the cap nut.
7. Close the fuel tank cover.

EVERY 1000 SERVICE HOURS

Carry out all the 50, 200, 250, and 500 hour servicings at the same time.

1. Replacing the hydraulic pilot filter element**! WARNING**

To avoid personal injury or death:

- Before replacing the element, wait long enough for the hydraulic fluid to cool down.

1. Open the side cover.

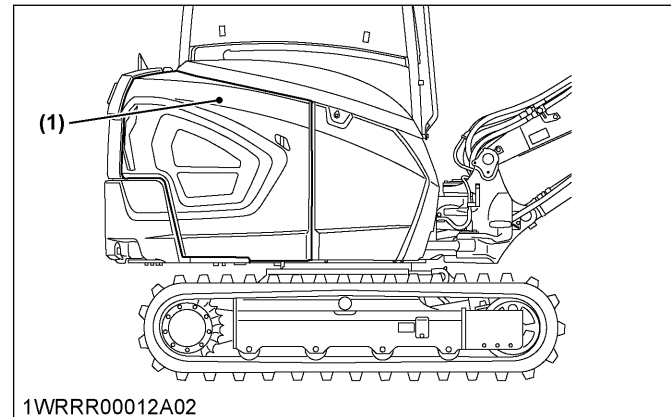

(1) Side cover

2. Remove the pilot filter case from the head cover.
3. Wrench and pull out the element downward.
4. Replace the O-ring with a new one.
5. Apply a light coating of clean hydraulic oil to the new O-ring and fit it to the case firmly. Be careful not to scratch the O-ring.
6. Attach the case to the head cover firmly.
7. Let the engine run for approximately 3 minutes.
8. Check the oil level of hydraulic oil tank, then tighten the oil filling plug.

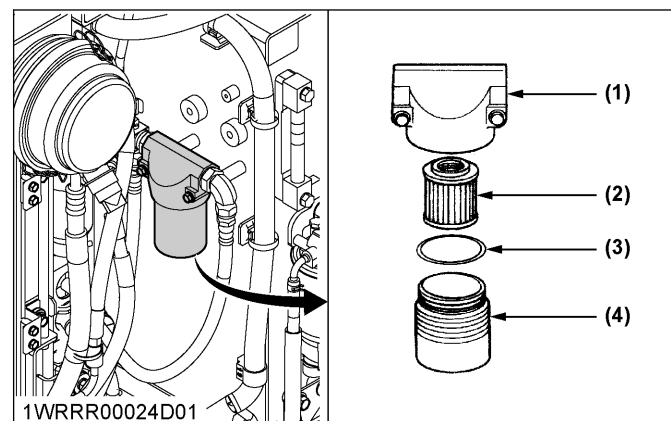

- (1) Head cover
 (2) Element
 (3) O-ring
 (4) Case

IMPORTANT :

- Users must take appropriate actions to insure hydraulic oil is not contaminated during the operation.
If hydraulic oil is spilled, wipe around the filter.

2. Replacing the hydraulic return filter element

! WARNING

To avoid personal injury:

- Remove the oil filter element only after the oil in the hydraulic tank has cooled down.
- There is a risk of being injured by hot pressurized hydraulic oil. Make sure that the oil has cooled down sufficiently, and then release the pressure before performing this service.

1. Open the side cover.
(See Opening and closing the side cover on page 119.)
2. Unscrew the cap nut on top of the breather filter, and push the button to release the pressure.

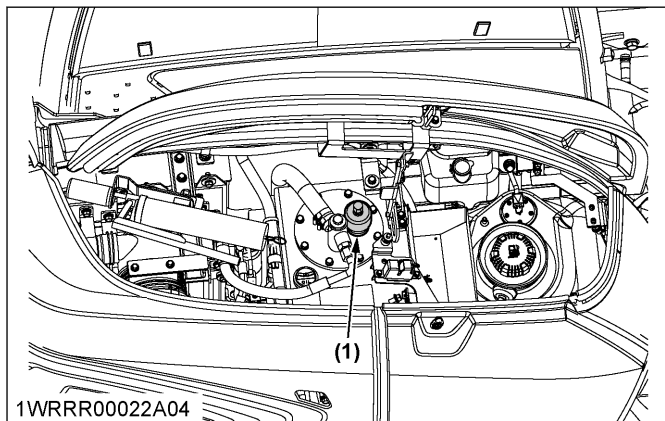

(1) Breather filter

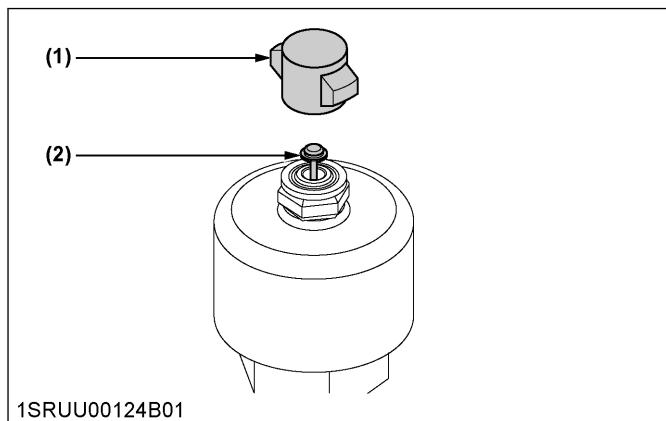

(1) Cap nut
(2) Button

3. Hold the filter support top and take the filter out of the tank.

4. Loosen the set bolt first and then detach the return filter from its support. Replace the filter with new one.
5. Take out and replace the breather filter with new one.
(See Replacing the hydraulic oil tank breather filter on page 139.)

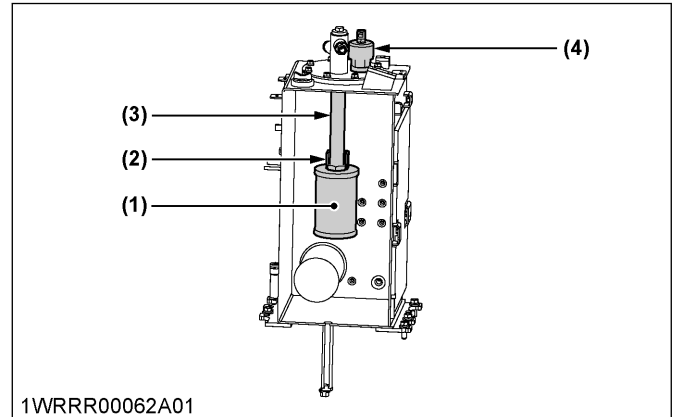

(1) Return filter
(2) Set bolt
(3) Filter support
(4) Breather filter

IMPORTANT :

- Always check the oil level after replacing the filter.
- Users must take appropriate actions to insure hydraulic oil is not contaminated during the operation.
If hydraulic oil is spilled, wipe around the hydraulic tank.

3. Changing the hydraulic oil (including replacing the suction filter)

! WARNING

To avoid personal injury or death:

- Wait long enough for the hydraulic fluid to cool down. Then, begin replacing the hydraulic fluid.
- There is a risk of being injured by hot pressurized hydraulic oil. Make sure that the oil has cooled down sufficiently, and then release the pressure before performing this service.

IMPORTANT :

- Users must take appropriate actions to insure hydraulic oil is not contaminated during the operation.
- If hydraulic oil is spilled, wipe around the hydraulic tank.

1. Park the machine on a firm, flat and level surface.

Lower the attachments and dozer blade to the ground and stop the engine.

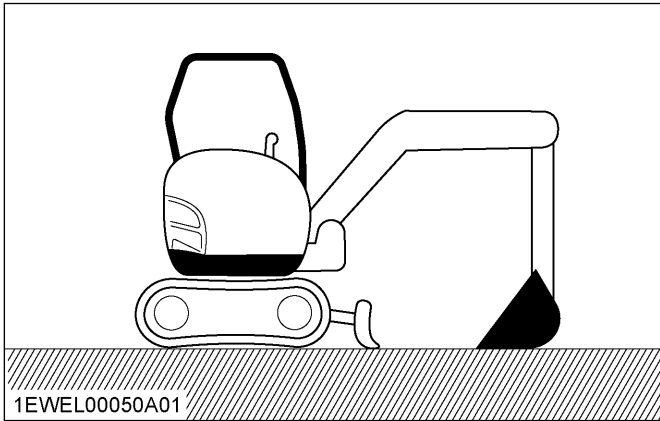

2. Open the fuel tank cover.
(See Opening and closing the fuel tank cover on page 118.)
3. Unscrew the cap nut on top of the breather filter, and push the button to release the pressure.

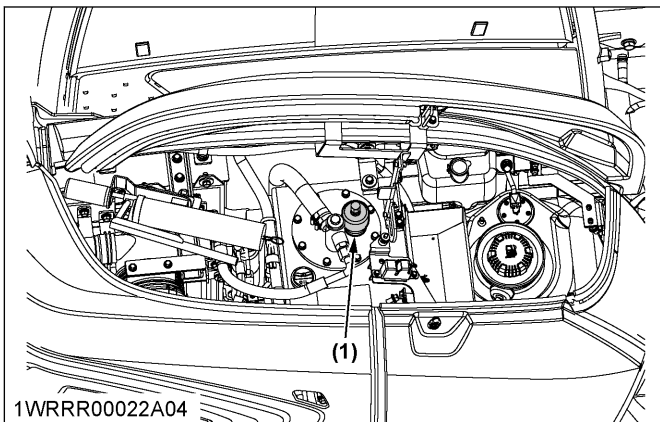

(1) Breather filter

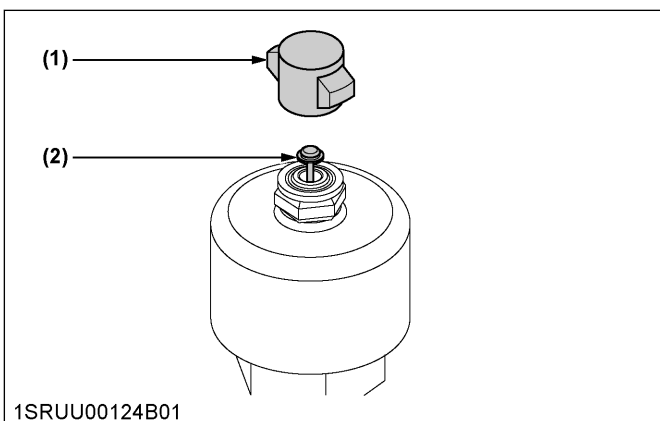

- (1) Cap nut
- (2) Button

4. Remove the drain plug located on the underside of the hydraulic tank and drain the oil.

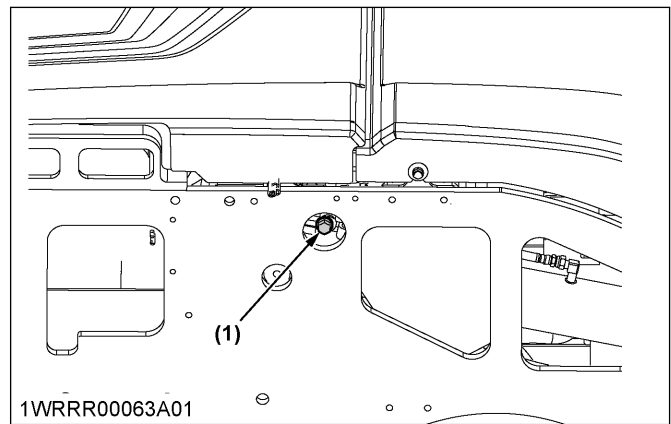

(1) Drain plug

5. Remove the suction filter lock pin and detach the suction filter.
6. Replace the filter with new one.
7. Retighten the drain plug.

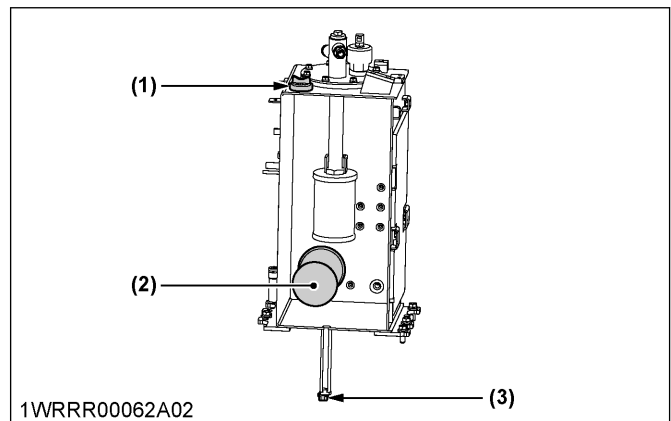

- (1) Oil filling plug
- (2) Suction filter
- (3) Drain plug

8. Open the side cover.
(See Opening and closing the side cover on page 119.)
9. Fill with oil through the oil filling opening on the top side of the tank up to the center of the gauge.

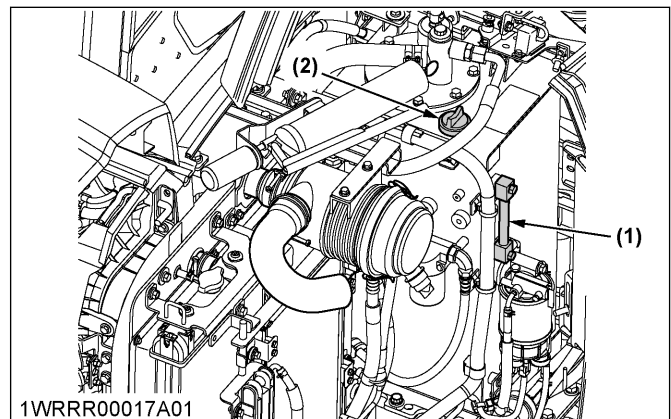

- (1) Gauge
- (2) Oil filling plug

Hydraulic oil volume	Hydraulic tank	37 L (9.8 U.S.gals)
	Whole oil volume	67 L (17.7 U.S.gals)

10. Install the hydraulic tank cover and tighten the oil filling plug.

IMPORTANT :

- Before starting the engine, make sure that the oil filling plug of hydraulic tank is properly tightened.

4. Checking the hydraulic oil (hydraulic hammer operation)

The hydraulic oil change after 1000 operating hours in the operator's manual is based on a standard machine. The following inspection measures are valid when a hydraulic hammer is used:

Changing and filling up with hydraulic oil

- The hydraulic oil must be changed more often when a hydraulic hammer is used because the machine is subject to harder conditions than standard excavating work.
- Use only the recommended oils mentioned in the operator's manual when changing or filling with oil.
- When filling up with oil, do not mix oils of different brands.

Replacing the filter and oil

- The filter must be replaced more often because of contamination resulting from the frequent assembly and disassembly of the hoses.
- Use the correct replacement filter.
- Change the oil according to operating hours.

		Hydraulic oil	Return filter
Normal excavator work		Every 1000 hrs	Every 1000 hrs
Breaker work portion	20 % or more	Every 800 hrs	Every 400 hrs
	40 % or more	Every 400 hrs	
	60 % or more	Every 300 hrs	Every 200 hrs
	80 % or more	Every 200 hrs	

5. Cleaning the auxiliary valve filter

Dust and dirt collect on the concave side of the filter.

IMPORTANT :

- To avoid oil leakage, do not reuse removed O-rings during reassembly.

1. Clean the pilot line filter by bleeding the cleaning fluid from the salient side.

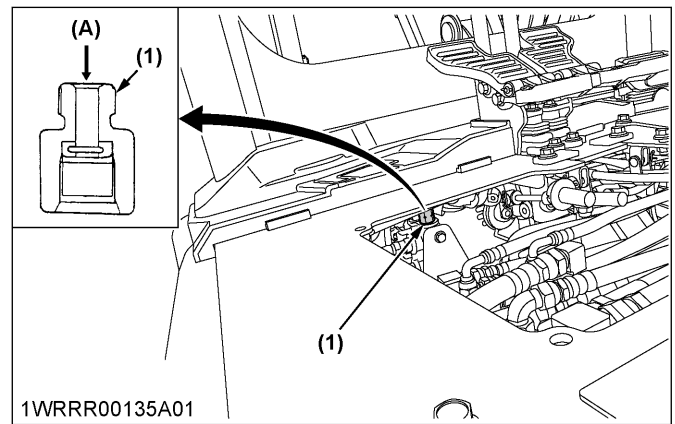

(1) Auxiliary valve filter (A) Direction of bleeding the cleaning fluid

6. Cleaning the pilot line filter

Dust and dirt collect on the concave side of the filter.

IMPORTANT :

- To avoid oil leakage, do not reuse removed O-rings during reassembly.

1. Clean the pilot line filter by bleeding the cleaning fluid from the salient side.
2. Clean the pilot line filter on the other side in the same manner.

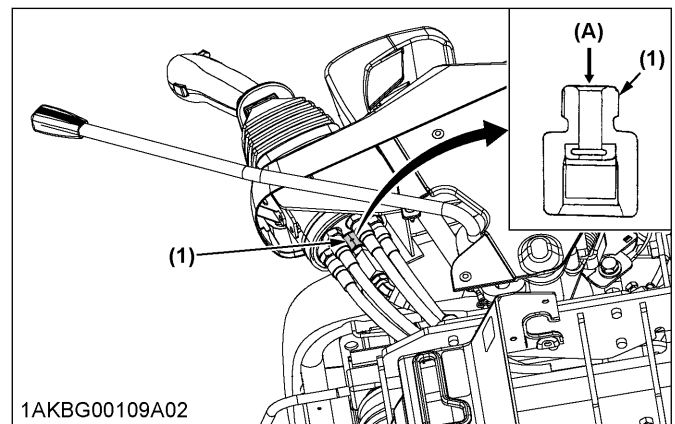

(1) Pilot line filter (A) Direction of bleeding the cleaning fluid

7. Checking the engine valve clearance

Contact your local Kubota dealer for this service.

EVERY 1000 SERVICE HOURS OR ONCE A YEAR

1. Replacing the air filter element

IMPORTANT :

- Replacement of the air filter components may be required when the machine is used in extreme conditions.
- Replace the air cleaner element regularly or foreign matters will accumulate, which will shorten the life expectancy of the DPF and reduce the cleaning efficiency of the DPF.

1. Open the side cover and remove the dust cover. (See Opening and closing the side cover on page 119.)
2. Remove and replace the outer element and inner element with new elements.

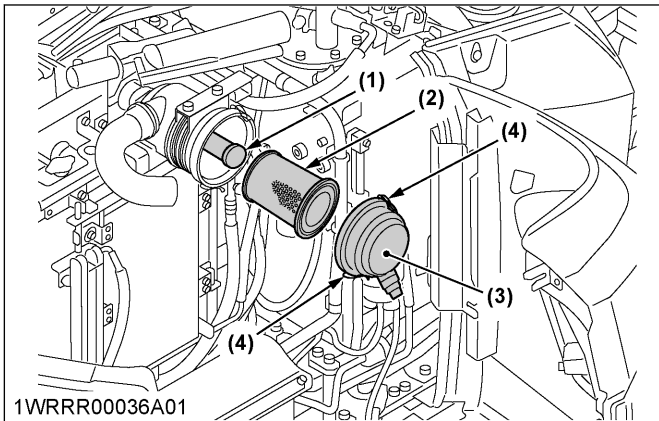

- 1WRRR00036A01
- (1) Inner element
 - (2) Outer element
 - (3) Dust cover
 - (4) Clamp

3. When reassembling, install the dust cover so that the "TOP" mark (arrow) points upward.

EVERY 1500 SERVICE HOURS

Carry out all the 50, 150, 250, and 500 hour servicings at the same time.

1. Checking the injector tip

Contact your local Kubota dealer for this service.

2. Checking the EGR cooler

Contact your local Kubota dealer for this service.

EVERY 2000 SERVICE HOURS

Carry out all the 50, 200, 250, 500, and 1000 hour servicings at the same time.

1. Changing the front idler and track roller oil

Contact your local Kubota dealer for this service.

2. Checking the alternator and starter motor

Contact your local Kubota dealer for this service.

EVERY 3000 SERVICE HOURS

Carry out all the 50, 150, 250, 500, 1000, and 1500 hour servicings at the same time.

1. Checking the EGR system

Contact your local Kubota dealer for this service.

2. Checking the turbo charger

Contact your local Kubota dealer for this service.

ANNUAL SERVICING

1. Checking the electrical wiring and fuses

1. Check the terminals periodically for proper connections.

NOTE :

- Loose wiring or damaged cables can cause improper functioning or short-circuiting of the electrical system.
2. Check the wiring and replace any damaged components immediately.
- NOTE :**
- If a fuse blows out soon after being replaced, contact your nearest Kubota dealer.
 - Never use a fuse other than the specified type.

2. Checking the air conditioner pipes and hoses

! WARNING

To avoid personal injury or death:

- Do not touch the coolant hoses or the heater with your hand. You may get burned.

1. Check to see that all lines and hose clamps are tight and not damaged.

- If hoses and clamps are found worn or damaged, replace or repair them at once. Contact your local Kubota dealer for this service.

3. Checking the exhaust manifold (cracks, gas leakage, and mounting screw)

Contact your local Kubota dealer for this service.

4. Checking the intake air line for air leaks

Contact your local Kubota dealer for this service.

5. Checking the boost sensor and AFS (Air Flow Sensor)

Contact your local Kubota dealer for this service.

6. Checking the condition of the diesel particulate filter (DPF) muffler

Contact your local Kubota dealer for this service.

7. Checking the diesel particulate filter (DPF) differential pressure sensor and piping for gas leaks

Contact your local Kubota dealer for this service.

8. Checking the diesel particulate filter (DPF) exhaust gas temperature sensor

Contact your local Kubota dealer for this service.

9. Checking the EGR piping for gas leaks

Contact your local Kubota dealer for this service.

BIENNIAL SERVICING

1. Replacing the air conditioner pipes and hoses

WARNING

To avoid personal injury or death:

- Do not touch the coolant hoses or the heater with your hand. You may get burned.

- Replace the air conditioner pipes and hoses every 2 years.
- If the hoses or pipes become swollen, hard, or cracked before 2 years has passed, replace them immediately.
- Contact your local Kubota dealer for this service.

2. Replacing radiator hoses and hose clamps

WARNING

To avoid personal injury or death:

- Do not loosen the radiator cap before the radiator has cooled down sufficiently. Loosen the cap only after allowing enough time for the pressure in the system to be reduced.
- Replace the radiator hoses and hose clamps every 2 years.
- If the hoses or pipes become swollen, hard, or cracked before 2 years has passed, replace them immediately.

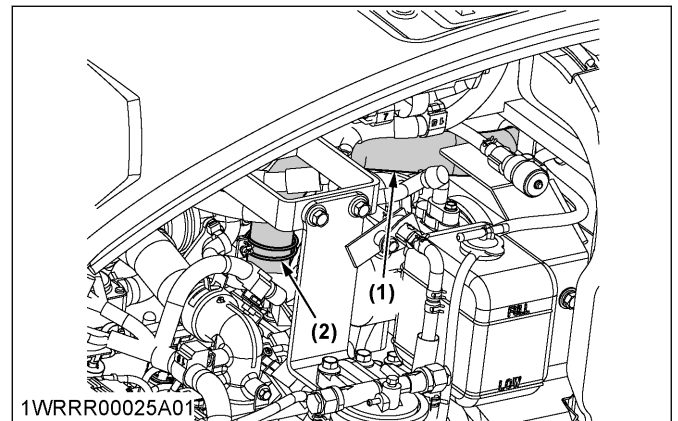

- (1) Rubber hose
(2) Hose clamp

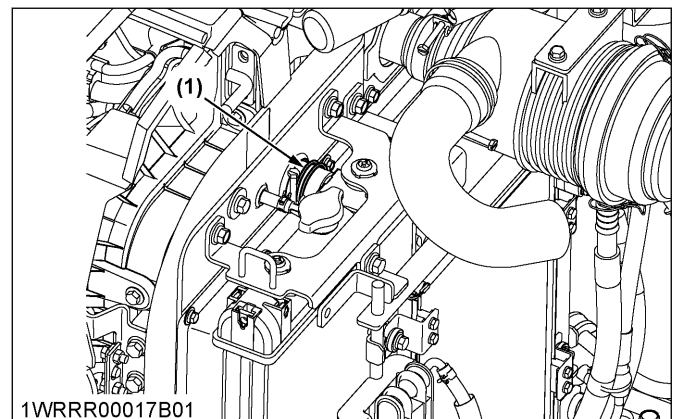

- (1) Hose clamp

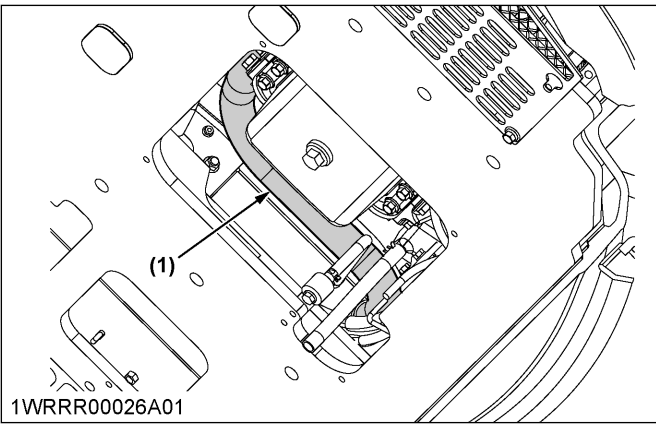

(1) Rubber hose

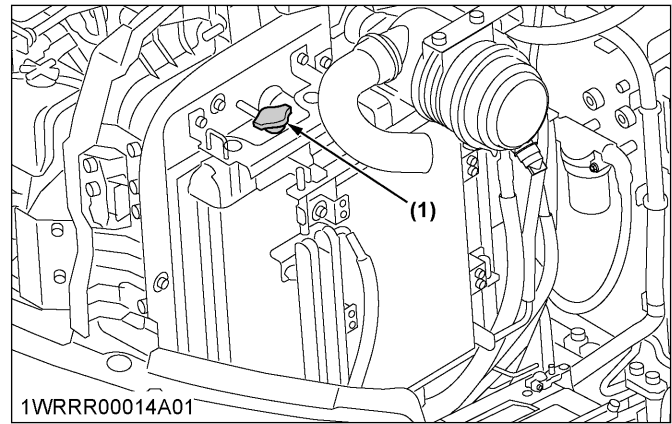

(1) Radiator cap

3. Changing the radiator coolant

WARNING

To avoid personal injury or death:

- When using antifreeze, use protective clothing such as rubber gloves.
- If swallowed, antifreeze is poisonous to people, animals, and birds.
- If you accidentally swallowed antifreeze, seek medical attention immediately.
- When antifreeze comes in contact with the skin or clothing, wash it off immediately.
- Do not mix different types of antifreeze. The mixture can produce a chemical reaction resulting in harmful substances.
- Antifreeze is extremely flammable and explosive under certain conditions. Keep antifreeze away from fire and children.
- When draining fluids from the engine, use a container underneath the engine body to catch the fluids.
- Do not pour waste onto the ground, down a drain, or into any water source.
- Also, observe the relevant environmental protection regulations when disposing of antifreeze.

1. Stop the engine, and then wait until the engine has cooled down completely.
2. Open the radiator cap.

3. Open the drain plug at the bottom of the radiator and drain the coolant completely. Should a recovery tank be equipped, disconnect the line from the tank floor and then open the drain plug.

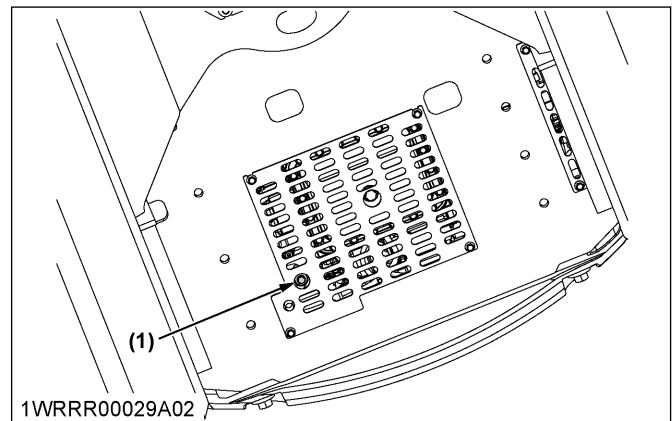

(1) Drain plug

4. Drain water while pouring water from the radiator water inlet.
5. Continue until clean water comes out of the outlet.
6. Close the drain plug.

Tightening torque	48.1 N·m to 55.9 N·m (35.5 lbf·ft to 41.2 lbf·ft)
-------------------	--

7. Fill the radiator and the recovery tank with coolant fluid.
8. Close the radiator cap.
9. Let the engine idle for about 5 minutes.
10. Stop the engine.

11. Check the coolant level of the recovery tank and add coolant if necessary.

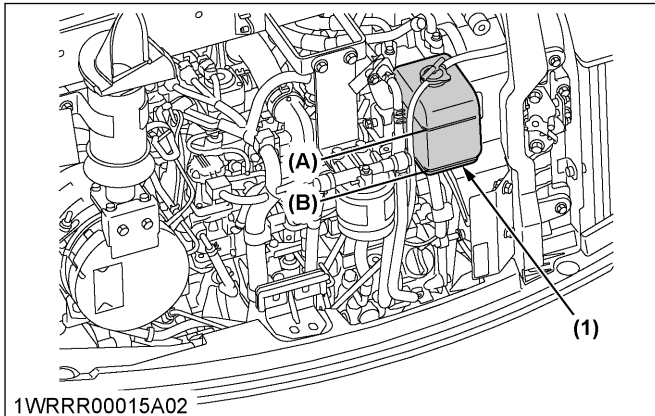

1WRRR00015A02

- (1) Recovery tank
- (A) FULL
- (B) LOW

Cooling water	Canopy	Approximately 6.7 L (1.7 U.S.gals)
	CAB	Approximately 7.0 L (1.8 U.S.gals)
Recovery tank		Approximately 1.1 L (0.29 U.S.gals)

NOTE :

- The shipped machine has been filled with 50 % antifreeze solution.

IMPORTANT :

- Do not operate the engine without coolant.
- To fill the radiator system and the recovery tank, use distilled water and antifreeze fluid.
- When the antifreeze is mixed with water, the antifreeze mixing ratio must be less than 50 %.
- Tighten the radiator cap properly. If the cap is loose or not properly fitted, it can cause engine overheating due to the loss of coolant fluid.

4. Replacing the fuel hoses and hose clamps

Replace the hoses and clamps.
(See Checking the fuel line and intake air line on page 134.)

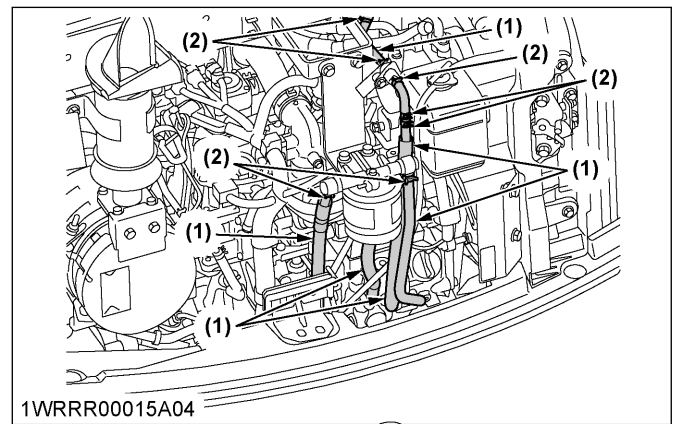

1WRRR00015A04

- (1) Fuel line
- (2) Clamp band

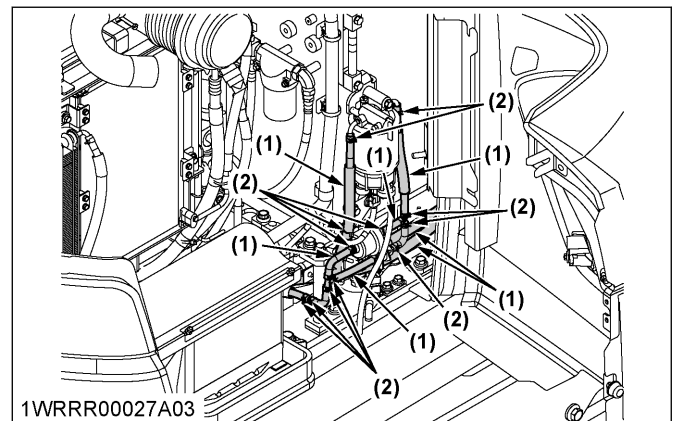

1WRRR00027A03

- (1) Fuel line
- (2) Clamp band

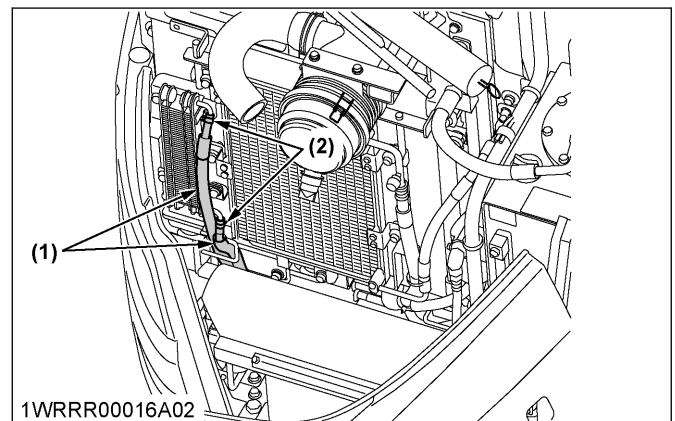

1WRRR00016A02

- (1) Fuel line
- (2) Clamp band

IMPORTANT :

- Replace all the fuel lines not only illustrated but also connected to the fuel tank, water separator, fuel filter, fuel cooler and so on, and clamps of them.

5. Replacing the intake air line

Replace the hoses and clamps, if necessary.
(See Checking the fuel line and intake air line on page 134.)

SERVICING AS REQUIRED

1. Checking the quantity of refrigerant (gas)

WARNING

To avoid personal injury or death:

- The contact of liquid with eyes or skin may cause frostbite.
- In case of leakage, wear safety goggles. Escaping refrigerant can cause severe injuries to eyes.
- When in contact with fire, the R134a refrigerant releases a toxic gas.
- Do not disconnect any parts of the refrigeration circuit of the air conditioning system. Contact your local Kubota dealer for assistance and service.

A shortage of refrigerant reduces the air conditioner performance. Check the following points. If it is indicated that the amount of refrigerant is extremely low, ask your dealer to inspect and refill.

Checking procedure

1. Run the air conditioner in the following conditions:
 - Engine speed at about 1500 rpm
 - Temperature control lever at the maximum cooling position (leftmost)
 - Fan switch at the highest blow (3)
 - Air conditioner switch at the "ON" position

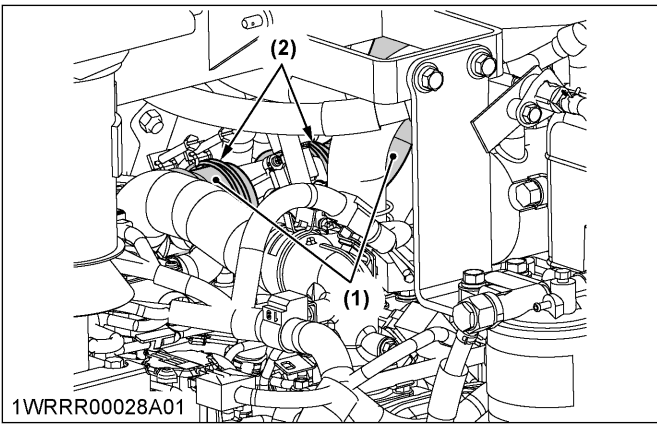

- (1) Hose
(2) Hose clamp

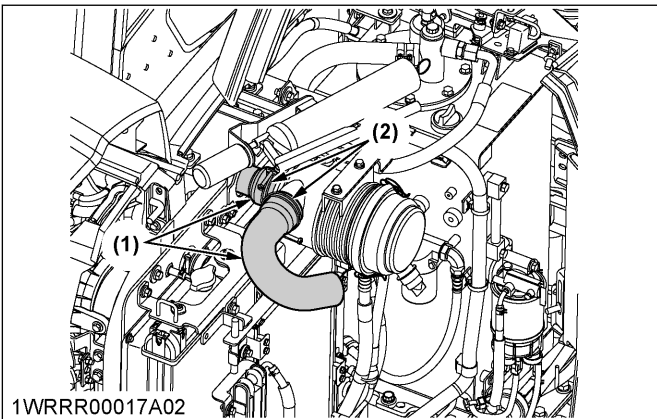

- (1) Hose
(2) Hose clamp

6. Replacing the diesel particulate filter (DPF) differential pressure sensor rubber piping (front and back)

Contact your local Kubota dealer for this service.

7. Replacing the suction pipe downstream the AFS (Air Flow Sensor)

Contact your local Kubota dealer for this service.

8. Replacing the EGR cooler hoses

Contact your local Kubota dealer for this service.

9. Replacing the hydraulic hoses

Contact your local Kubota dealer for this service.

- 2. Look into the sight glass to see if the refrigerant is flowing through its circuit.

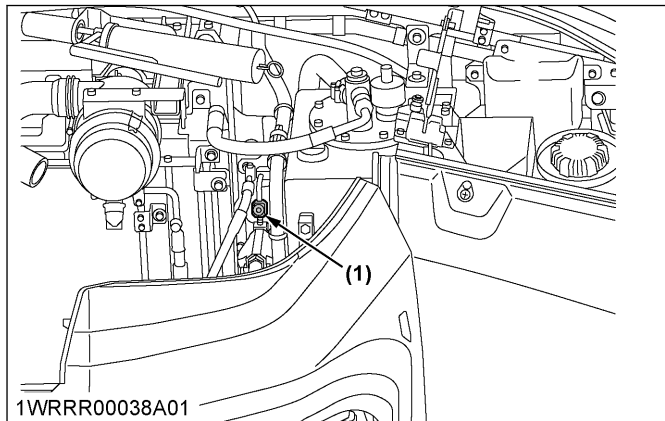

(1) Sight glass

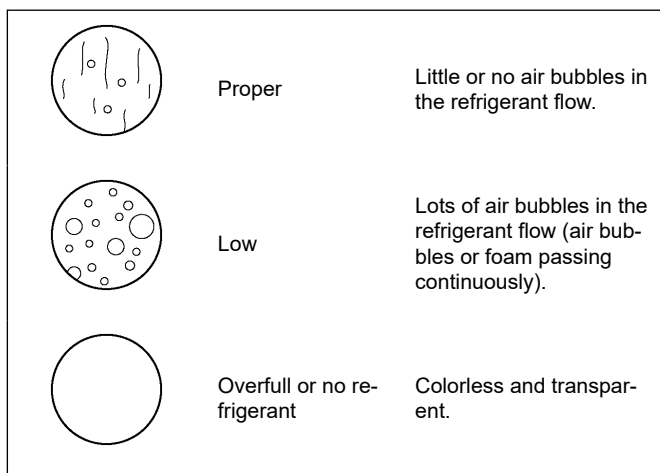

IMPORTANT :

- Charge only with R134a, not R12 refrigerant (gas).

2. Draining the water separator

If the following fuel filter water error message appears on the display, immediately drain the water separator. (See Cleaning the water separator on page 129.)



IMPORTANT :

- If you do not drain the water separator immediately after the alarm, the engine may be seriously damaged.

- Without the water separator drained, the cleaning efficiency of the DPF will be reduced and the DPF longevity will be shorter than expected.

3. Cleaning the diesel particulate filter (DPF)

The longer the DPF operates, the more ash (burnt residue) is collected in the filter. Too much ash build-up adversely affects the DPF performance.

When the DPF cleaning time draws near, the message “DPF cleaning soon” appears on the display. When this message appears, clean the DPF.

Contact your local Kubota dealer to clean the DPF.

IMPORTANT :

- To clean up the DPF, a specific machine is required. Do not attempt to clean it in any other way, such as disassembling, shaking and heating as toxic chemicals may be present inside of the DPF.

4. Cleaning the plastic parts and synthetic leather

- Use a soft cloth when wiping plastic parts or synthetic leather.
- If the plastic or synthetic leather is very dirty, use a soft cloth dipped in a mild detergent that has been diluted with water.
- Wipe off any remaining moisture or detergent with a soft cloth that has been moistened with water and then thoroughly wrung out.
- Cleaning the plastic parts with alkaline, acidic, or organic solvents such as alcohol or benzene can damage them.

OTHER ADJUSTMENTS AND REPLACEMENTS

PURGING THE FUEL SYSTEM

1. Fill up the fuel tank with fuel.
2. Turn the starter switch to the [RUN] position.
3. The air in the fuel system will automatically be purged within 1 minute.

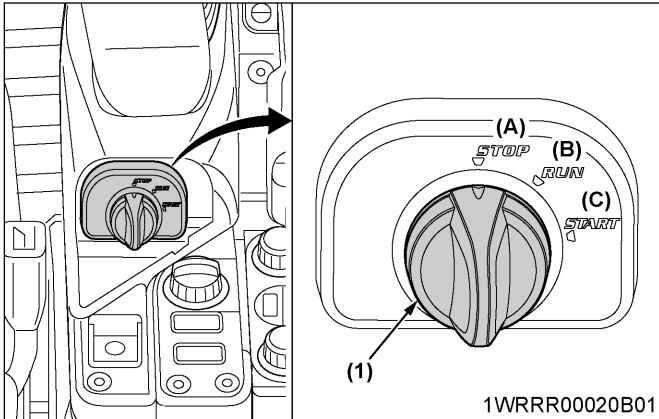

(1) Starter switch

(A) STOP
(B) RUN
(C) START

IMPORTANT :

- If the purging was insufficient, the engine stops right after starting. In this case, repeat steps 2 to 3.

NOTE :

- If the air doesn't bleed out easily, press the engine's priming pump repeatedly (10 to 30 times) until the pump feels stiff.

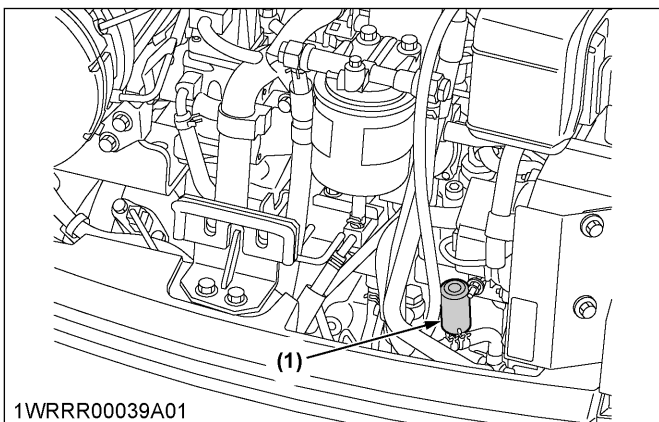

1WRRR00039A01

(1) Priming pump

ADJUSTING THE TRACKS

⚠ WARNING

To avoid personal injury or death:

- Make sure that no obstacles, such as stones are caught in the track. Remove such obstacles before adjusting the track tension.
- Do not crawl under the machine.

IMPORTANT :

- If the tracks are too tight, wear is increased.
- If the tracks are too loose, the track pads may collide with the sprocket, wear is increased. The track may dislocate or come off.
- Clean the track after every use.

1. Adjusting steel tracks

IMPORTANT :

- Should the track tension be high due to sticking mud, lift the track with the help of the boom, arm and bucket, idle the engine and remove mud from the track, especially from the openings of the link plate carefully.

Tensioning

1. Loosen the bolt of the cover and remove the cover.
2. Apply grease to the grease fitting.

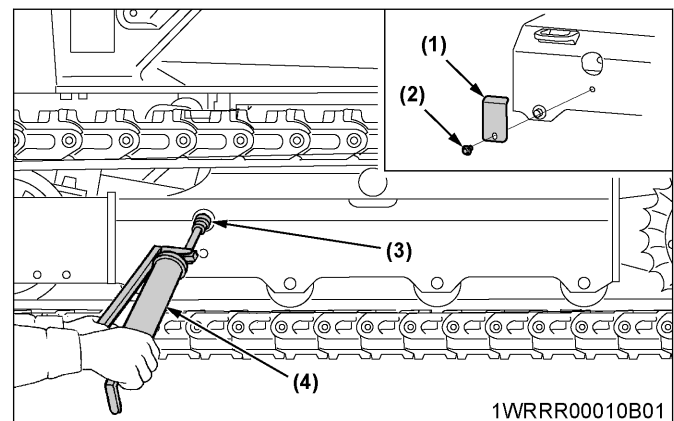

1WRRR00010B01

- (1) Cover
- (2) Bolt
- (3) Grease fitting
- (4) Grease gun

3. To check the track tension, lift the track from the ground as shown in the following illustration. The track tension is correct if the clearance between the outer end of the track roller and the track interior

surface corresponds to the dimension specified in the following table.

Clearance	85 mm to 90 mm (3.35 in. to 3.54 in.)
-----------	---------------------------------------

! DANGER

To avoid serious injury or death:

- Do not work under the machine in this condition.
- For your safety, do not rely on hydraulically supported devices. They may leak down and suddenly drop or be accidentally lowered.

! WARNING

To avoid personal injury or death:

- When lifting the machine itself with an attachment, place a safety block or safety post to prevent the machine from turning over. Keep the pilot control lock lever in the LOCK position.

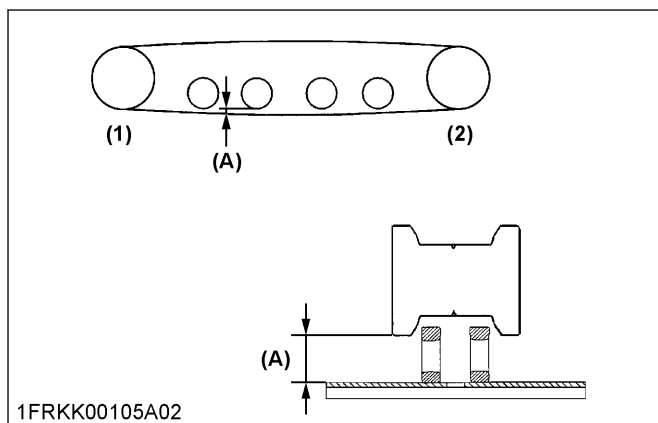
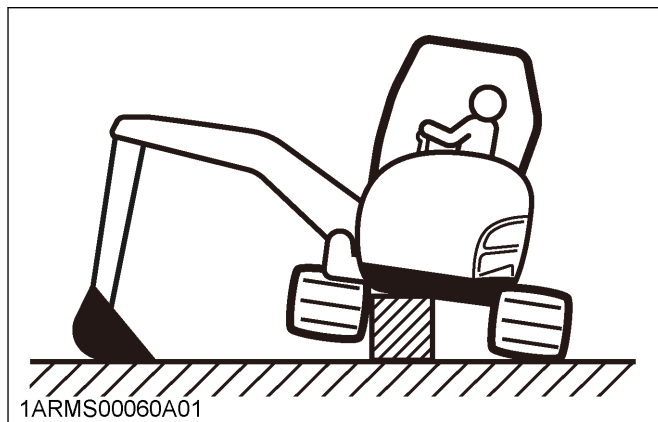

(1) Idler
(2) Drive sprocket

(A) 85 mm to 90 mm (3.35 in. to 3.54 in.)

Loosening

! WARNING

To avoid personal injury:

- Do not loosen the grease fitting completely or too quickly. Otherwise grease under high pressure in the tension cylinder could squirt out.

1. Loosen the bolt of the cover and remove the cover.
2. Using a socket wrench, loosen the grease fitting a few turns.
3. When grease oozes out from the thread, rotate the track and loosen the track in the lifted position.
4. After adjustment is completed, tighten the grease fitting using a socket wrench. Tightening torque must be between 98 N·m to 108 N·m (72.3 ft·lbs to 79.7 ft·lbs).

2. Adjusting rubber tracks

IMPORTANT :

- Should the track tension be high due to sticking mud, lift the track with the help of the boom, arm and bucket, idle the engine and remove mud from the track by rotating it.
- Track seam.
The ends of the rubber track are joined with a seam. When adjusting the tracks, the seam must be positioned on the top center between the idler and the sprocket. If the seam is positioned incorrectly, the tracks will be tensioned to loosely, and a further readjustment will be necessary.
- Rotate the track after adjustment one to two times to check the tension.
- Additionally following points are to be observed when adjusting rubber tracks.
 - If the track slackens more than 50 mm (2.0 in.), readjust them.
 - Check track tension 50 hours after initial use and readjust if necessary. Check and adjust thereafter every 50 service hours.

Tensioning

1. Loosen the bolt of the cover and remove the cover.
2. Apply grease to the grease fitting.

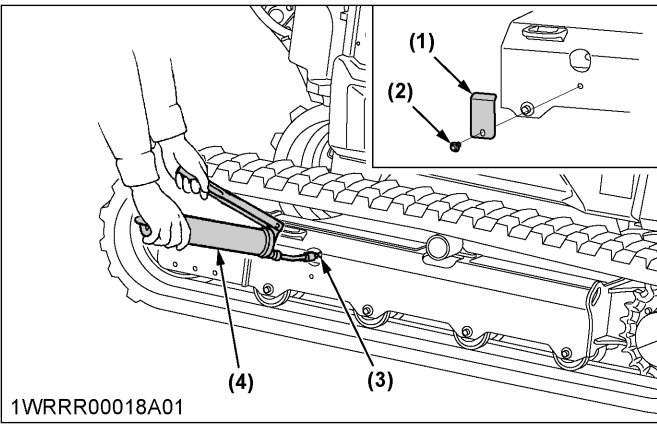

- (1) Cover
- (2) Bolt
- (3) Grease fitting
- (4) Grease gun

3. Tension the track in the lifted position, so that the distance "A" (clearance between the track roller and the inside surface of the track) is 10 mm to 15 mm (0.39 in. to 0.59 in.), as shown in the following illustration.
In this case, the track seam is positioned on the top center between the idler and the sprocket.

Clearance	10 mm to 15 mm (0.39 in. to 0.59 in.)
-----------	---------------------------------------

! DANGER

To avoid serious injury or death:

- Do not work under the machine in this condition.
- For your safety do not rely on hydraulically supported devices, they may leak down and suddenly drop or be accidentally lowered.

! WARNING

To avoid personal injury or death:

- When lifting the machine itself with an attachment, place a safety block or safety post to prevent the machine from turning over. Keep the pilot control lock lever in the LOCK position.

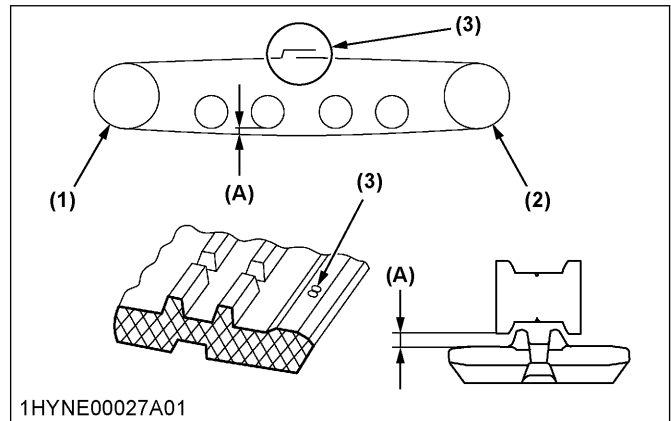
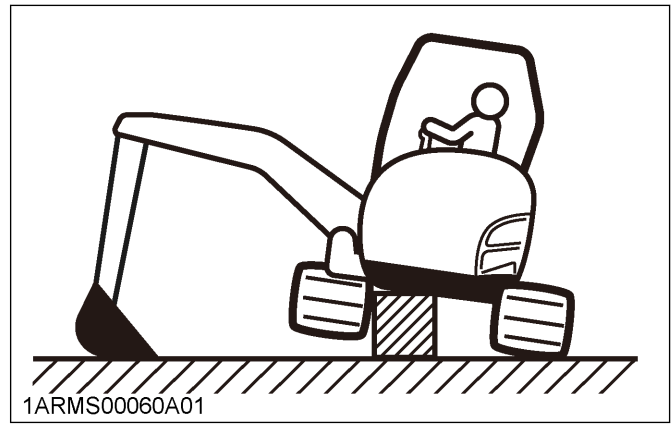

- (1) Idler
- (2) Drive sprocket
- (3) Seam (Marked [∞])
- (A) 10 mm to 15 mm (0.39 in. to 0.59 in.)

Loosening

! WARNING

To avoid personal injury:

- Do not loosen the grease fitting completely or too quickly. Otherwise grease under high pressure in the tension cylinder could squirt out.

1. Loosen the bolt of the cover and remove the cover.
2. Using a socket wrench, loosen the grease fitting a few turns.
3. When grease oozes out from the thread, rotate the track and loosen the track in the lifted position.
4. After adjustment is completed, tighten the grease fitting using a socket wrench.
Tightening torque must be between 98 N·m to 108 N·m (72.3 ft·lbs to 79.7 ft·lbs).

2.1 Special information regarding the use rubber tracks

- When turning, make a slow swivel turn. Avoid spin turns to lessen lug wear and entry of dirt.
- The relief valve may be activated if too much dirt and sand clog the tracks. In this case move the machine for a short distance straight backwards to

let the earth and sand fall off, then a turn can be made.

- Avoid using rubber track on riverbeds, stony underground, ferro-concrete and on iron plates. The rubber can damage as well as increase wear on the tracks.

CHANGING THE BUCKET

WARNING

To avoid personal injury or death:

- Two people are required to replace the bucket. One person operates the machine, and the other one mounts the bucket. The person who mounts the bucket must command and guide the movements of the front end attachments. The operator should move the front end attachments only according to the commands of the person who mounts the bucket. Continuous visibility between both persons is indispensable. If there is no visibility, stop working immediately.
- When replacing the bucket, make sure to wear eye protection, a helmet, and protective gloves.
- During attaching and detaching, chippings and burrs may occur at the bolts or bushings. These may cause severe injuries.
- Never use your fingers for the alignment of the components (linkage, bucket, and arm). The components may sever your fingers due to the uncontrolled movements.
- When other attachments are installed instead of a Kubota specified bucket, read the attachment manual to perform safe operation.

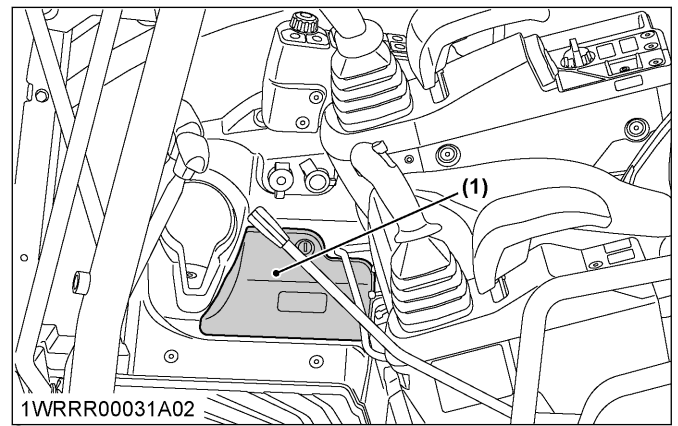

(1) Cover

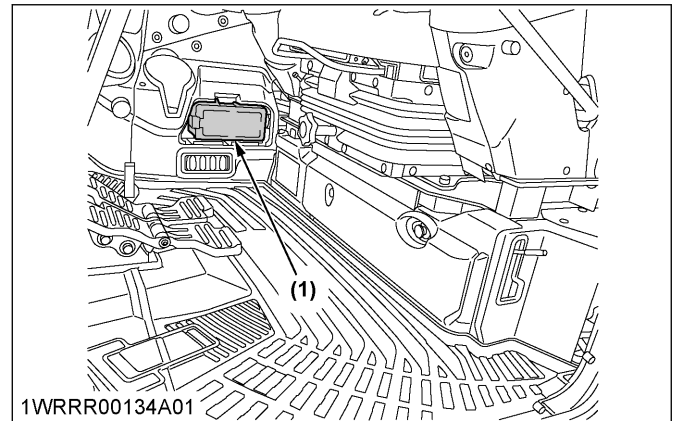

(1) Fuse box

REPLACING FUSES

WARNING

To avoid personal injury or death:

- When changing fuses, stop the engine and turn the starter switch to [STOP] position. Keep the pilot control lock lever in the LOCK position.
1. Remove the cover of the fuse box.
 2. Replace the burnt out fuse with a fuse which has the same capacity.

Fuse capacities and circuits

[Canopy]

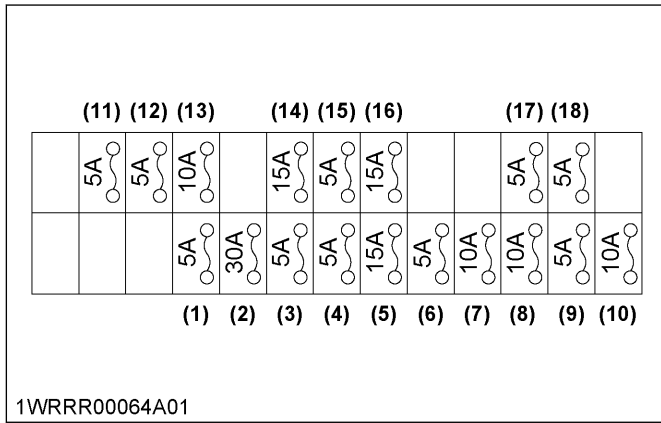

(1)	METER (+B)	(11)	ECU (ACC)
(2)	ECU (Power)	(12)	Lever Lock
(3)	Horn Switch	(13)	Alternator
(4)	Room Light	(14)	Electrical Outlet
(5)	Beacon	(15)	Fuel Pump
(6)	KOBO ACE	(16)	Radio (ACC)
(7)	Horn	(17)	CRS
(8)	ECU (+B)	(18)	Sarter
(9)	Front Work Light		
(10)	Cab Work Light		

[CAB] (Air-conditioner type)

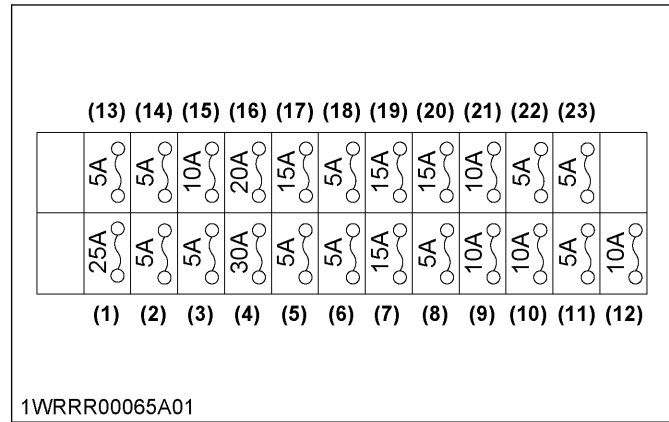

(1)	Blower Motor	(13)	ECU (ACC)
(2)	A/C Controller	(14)	Lever Lock
(3)	Meter (+B)	(15)	Alternator
(4)	ECU (Power)	(16)	Seat
(5)	Horn Switch	(17)	Electrical Outlet
(6)	Room Light	(18)	Fuel Pump
(7)	Beacon	(19)	Radio (ACC)
(8)	KOBO ACE	(20)	Wiper/Washer
(9)	Horn	(21)	Compressor
(10)	ECU (+B)	(22)	CRS
(11)	Front Work Light	(23)	Starter
(12)	Cab Work Light		

REPLACING SLOW-BLOW FUSES

A slow-blow fuse is provided to protect the electrical circuits. If a slow-blow fuse is blown, check the electrical circuits for trouble and then replace with a new compatible slow-blow fuse.

⚠ WARNING
 To avoid personal injury or death:

- When changing fuses, stop the engine and turn the starter switch to [STOP] position. Keep the pilot control lock lever in the LOCK position.

IMPORTANT :

- The main fuse protects the entire electrical system. If the main fuse or another fuse has blown, determine why it blew and make any necessary repairs.
 Never bridge fuses, always replace them with a new fuse of the same rating.

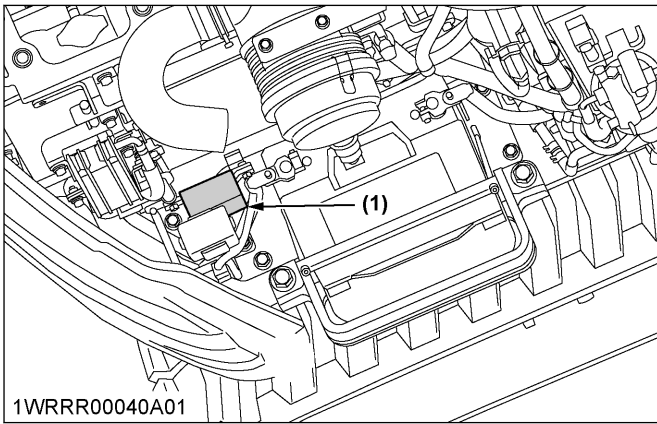

(1) Slow-blow fuse case

1. Disconnect the negative cord of the battery.
2. Remove the slow-blow fuse case.
3. Open the slow-blow fuse case cap and covers, then remove the bolts and draw out the slow-blow fuse (A) and fuse (B).

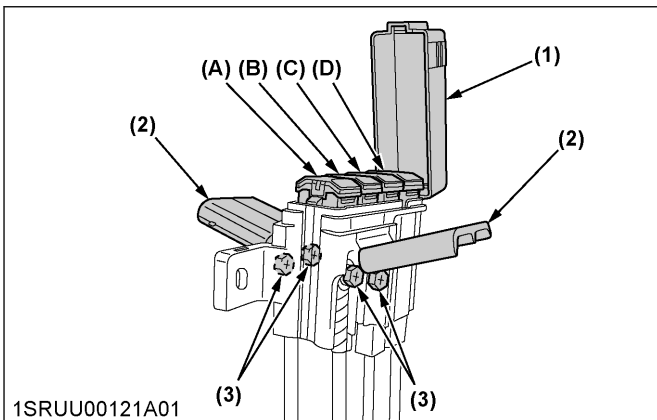

- (1) Slow-blow fuse case cap
 (2) Cover
 (3) Bolt

(A)	Alternator	80 A
(B)	Main Power (1)	60 A
(C)	Main Power (2)	50 A
(D)	Engine	30 A

TROUBLESHOOTING

TROUBLESHOOTING OF THE ENGINE AND OTHER SYSTEMS

If the machine does not perform as desired, or when trouble arises, refer to the following table and carry out the appropriate measures.

Trouble		Cause	Countermeasure
Engine	Starting difficulties	Pilot control lock lever is in the UNLOCK position.	<ul style="list-style-type: none"> Bring pilot control lock lever into the LOCK position.
		Fuel is too viscous or dirty.	<ul style="list-style-type: none"> Check the fuel tank and filter. Remove impurities and water. If necessary, replace the filter.
		Air or water is in the fuel system.	<ul style="list-style-type: none"> Remove water from the fuel tank. Check the fuel pipe joint bolts and nuts for looseness. Purge of the fuel system. Details regarding the purging operation for fuel filter and injection pump can be found in a different section. (See PURGING THE FUEL SYSTEM on page 150)
		Oil viscosity is too high and the engine runs sluggishly in the winter.	<ul style="list-style-type: none"> Pour hot water over the radiator.
		Battery is almost dead. Insufficient compression	<ul style="list-style-type: none"> Recharge the battery.
	Insufficient engine power	Low fuel level	<ul style="list-style-type: none"> Check the fuel level and add fuel if necessary.
		Clogged air filter	<ul style="list-style-type: none"> Clean the air filter element.
	Engine suddenly stops.	Low fuel level	<ul style="list-style-type: none"> Check the fuel level and add fuel if necessary. Purge the fuel system.
		Clogged fuel filter	<ul style="list-style-type: none"> If necessary, replace filter.
	Abnormal exhaust gas color	Poor quality fuel	<ul style="list-style-type: none"> Use high quality fuel.
		Too much engine oil	<ul style="list-style-type: none"> Drain the engine oil to the prescribed oil level.
	Water temperature in red zone (overheating)	Flawed seal of the water pump	<ul style="list-style-type: none"> Replace.
		Worn or torn V-belt	<ul style="list-style-type: none"> Adjust or replace.
		Thermostat is flawed.	<ul style="list-style-type: none"> Replace.
		Coolant level is too low.	<ul style="list-style-type: none"> Fill to the prescribed level.
		Radiator grill or fins are clogged.	<ul style="list-style-type: none"> Clean.
		Coolant is contaminated with rust from the cylinder head or crank case.	<ul style="list-style-type: none"> Replace the coolant fluid and add anti-rust.
		Radiator cap is damaged (evaporation)	<ul style="list-style-type: none"> Replace.
		Corroded coolant pipes	<ul style="list-style-type: none"> Clean.
		Continuous operation under full load	<ul style="list-style-type: none"> Reduce load.
Cylinder head gasket is damaged (coolant loss).		<ul style="list-style-type: none"> Replace. 	
Engine oil level is too low.		<ul style="list-style-type: none"> Fill to the prescribed level. 	
Maladjustment of fuel injection		<ul style="list-style-type: none"> Readjust the ignition timing. 	

(Continued)

Trouble		Cause	Countermeasure
Engine	Water temperature in red zone (overheating)	Use of poor fuel	<ul style="list-style-type: none"> • Use the prescribed fuel.
Hydraulic system	Boom, arm, bucket, drive, swivel and dozer power is too low.	Hydraulic oil level is too low.	<ul style="list-style-type: none"> • Add oil.
		Leakage of hoses and/or joints	<ul style="list-style-type: none"> • Replace the hose or joint.
	Swivel motor and front attachment does not work.	Pilot control lock lever is in the LOCK position	<ul style="list-style-type: none"> • Bring the pilot control lock lever into the UNLOCK position.
Drive system	Deviation of drive direction	Blocked with stones	<ul style="list-style-type: none"> • Remove.
		Track is too loose or too tight.	<ul style="list-style-type: none"> • Adjust accordingly.
DPF		See AUTOMATIC DIESEL PARTICULATE FILTER (DPF) REGENERATION on page 187 and LOCKING AND RELEASING THE DIESEL PARTICULATE FILTER (DPF) REGENERATION on page 189.	

OPERATION IN COLD WEATHER

PREPARATION FOR WORK IN COLD WEATHER

- Replace engine oil and hydraulic oil with those of viscosities suitable for cold weather.
- In cold weather, battery power drops, and the battery fluid may freeze if the battery is not sufficiently charged. To prevent the battery fluid from freezing, keep the battery charged at least 75% or more of its capacity after operation. So that the machine starts easily next time, it is recommended to keep the battery stored in closed or heated rooms. If the battery fluid level is too low, do not add after operation, but add with the engine running before the next operation.
- Add antifreeze to coolant in the radiator and recovery tank, if the ambient temperature is expected to drop below 0 °C. Mixing ratio of water and antifreeze depends on the expected ambient temperature.

Mixing ratio between water and antifreeze

Ambient temperature	°C (°F)	-5 (+23)	-10 (+14)	-15 (+5)	-20 (-4)	-25 (-13)	-30 (-22)	-35 (-31)
Antifreeze	%	30	30	30	35	40	45	50
Water	%	70	70	70	65	60	55	50

IMPORTANT :

- **Use permanent antifreeze or long-life coolant.**
- **Drain the coolant completely and clean the inside of the radiator, then fill with the water and antifreeze mixture.**
- **The antifreeze acts as an anti-corrosive, it is not necessary to add an additive to the water and antifreeze mixture.**
- **Details regarding the radiator fill volumes can be found in a different section.**
(See Checking the coolant level on page 120.)

AFTER WORKING IN COLD WEATHER

- Clean the machine thoroughly after work and wipe dry. Otherwise mud and earth on the tracks could freeze if the temperature drops below the 0°C (32°F) mark. Operation of the machine is then not possible.
- Store the machine in a dry place. If not possible, store on wooden planks or on mats. If the machine is kept on damp or muddy ground, the tracks could

freeze overnight. Operation of the machine is then not possible. Furthermore the drive unit may be damaged.

- The piston rods of the hydraulic cylinders must be rubbed dry. Otherwise severe damage could occur if dirty water seeps through the seals.

LONG-TERM STORAGE



WARNING

To avoid personal injury or death:

- Do not clean the machine while the engine is running.
- To avoid the danger of exhaust fume poisoning, do not operate the engine indoors without proper ventilation.
- Park the machine on a firm, flat, and level surface. Lower the attachments and dozer blade to the ground.

STORING THE MACHINE

If the machine is stored for a longer period of time, observe the following procedures:

1. The whole machine should be cleaned thoroughly and should be stored indoors in all cases. If the machine has to be kept outdoors, arrange wooden planks on even ground, place the machine on the planks, and cover it completely.
2. Change the oil and grease the machine.
3. Heavily grease the visible section of the cylinder rods.
4. Remove the battery and store indoors.
5. If it is expected that the temperature will sink below the 0 °C (32 °F) mark, add antifreeze or drain the coolant completely.

IMPORTANT :

- **Wash the machine after stopping the engine.**
If you wash the machine while the engine is running, water can splash and get into the air cleaner through its intake and cause engine damage.

OPERATING THE MACHINE AFTER LONG-TERM STORAGE

1. Wipe off the grease from the hydraulic cylinder rods.
2. Thoroughly inspect the machine and clean off any debris.
3. Turn on the engine. Operate the attachment and the drive mechanisms under no load in order to circulate the hydraulic oil.

If the machine is stored for longer than 1 month, carry out steps 1 and 2 once every month.

PERIODIC REPLACEMENT OF PARTS

To ensure safe operation, inspect and service the machine at regular intervals. For added safety, ask your Kubota dealer to replace the following important parts.

These parts are prone to material degradation or subject to wear and tear with time. It is difficult to judge how much they have been affected at a regular inspection. Therefore, it is necessary to replace them with new ones, regardless of whether wear is visible or not after a specified time of use.

If any of them are found worn even before the specified time of use, they must be repaired or replaced the same way as other parts.

LONG-TERM STORAGE

If any of the hose clamps are found deformed or cracked, they must also be replaced.

For the hydraulic hoses other than the ones to be replaced periodically, inspect them for the following points. If found in an unusual condition, tighten them up or replace them.

When replacing the hydraulic hoses, change their O-rings and sealings with new ones.

For replacement of the important parts, contact your local Kubota dealer.

While performing the following periodic inspections, check the fuel hoses and hydraulic hoses also.

Inspection interval	Check points
Daily checks	Oil leak at fuel and hydraulic hose connections and points
Every month	Oil leak at fuel and hydraulic hose connections and points Damage at fuel and hydraulic hose (cracks, chafing)
Every year	Oil leak at fuel and hydraulic hose connections and points Interference, deformation, degradation, twist and other damage (cracks, chafing) of fuel and hydraulic hoses

List of important component parts

No.	Component parts	Period
1	Fuel hose	Every 2 years or 4000 hours
2	Hydraulic hose (suction)	
3	Hydraulic hose (delivery)	
4	Hydraulic hose (boom cylinder)	
5	Hydraulic hose (arm cylinder)	
6	Hydraulic hose (bucket cylinder)	
7	Hydraulic hose (swing cylinder)	
8	Hydraulic hose (dozer cylinder)	
9	Hydraulic hose (service port)	
10	Hydraulic hose (swivel motor)	
11	Hydraulic hose (travel motor)	
12	Hydraulic hose (angle cylinder)	
13	DPF differential pressure sensor rubber piping (front and back)	
14	Suction pipe downstream the AFS (air flow sensor)	

To prevent serious damage to the hydraulic system, use only a Kubota genuine hydraulic hose.

RECOMMENDED OILS AND FUELS

IMPORTANT :

- Before delivery, the hydraulic oil used was Shell Tellus S2M46.
- Use engine oil API service classification CJ-4 or CK-4.
- Use SAE 90 (API, GL-4/GL-5) as drive unit oil for all seasons.
- To change the engine oil, hydraulic oil, gear oil or the like, drain all of the oil and replace it with fresh oil. When adding oil, use the same brand and same type of oil.
- Other than the oil mentioned below, JCMAS HK certified oil and GK certified grease can also be used. Check the Japan Lubricating Oil Society (JALOS) website for more details.

	Application	Viscosity	KTC *1 recommends	Shell	ExxonMobil
Gear oil	All-weather gear oil	SAE 90	Excavator gear oil 90	Shell Spirax HD80W-90	Mobilube HD Plus 80W-90
Hydraulic oil	In winter or in low temperatures	ISO 32	Excavator hydraulic fluid 32	Shell Tellus S2M32 or Shell Tellus S2MX32	
	In summer or in high ambient temperatures	ISO 46	Excavator hydraulic fluid 46	Shell Tellus S2M46 or Shell Tellus S2MX46	
Grease				Shell Alvania EP2	Mobilux EP2
Fuel				Diesel fuel No.2-D S15	
Fuel under -5 °C (23 °F)				Diesel fuel No.1-D S15	

*1 KTC is an abbreviation for Kubota Tractor Corporation.

	Application	Viscosity	KCL *1 recommends	Shell	Esso
Gear oil	All-weather gear oil	SAE 90		Shell Spirax HD75W-90	Mobilube HD80W-90
Hydraulic oil	In winter or in low temperatures	ISO 32	KUBOTA ALL SEASON HYDRAULIC EXCAVATOR OIL	Shell Tellus S2M32 or Shell Tellus S2MX32	
	In summer or in high ambient temperatures	ISO 46		Shell Tellus S2M46 or Shell Tellus S2MX46	
Grease				Shell Alvania EP2	Mobilux EP2
Fuel				Diesel fuel No.2-D S15	
Fuel under -5 °C (23 °F)				Diesel fuel No.1-D S15	

*1 KCL is an abbreviation for Kubota Canada Ltd.

Engine oil:

- Oil used in the engine should have an American Petroleum Institute (API) service classification and Proper SAE engine oil according to the ambient temperatures.

Above 25 °C (77 °F)	SAE 30 or SAE 10W-30, SAE 15W-40
0 °C to 25 °C (32 °F to 77 °F)	SAE 20 or SAE 10W-30, SAE 15W-40
Below 0 °C (32 °F)	SAE 10W or SAE 10W-30, SAE 15W-40

- Refer to the following table for the suitable API classification engine oil and the fuel.

RECOMMENDED OILS AND FUELS

Fuel used	Engine oil classification (api classification)
	Oil class of engines with DPF
Ultra low sulfur fuel [<0.0015% (15 ppm)]	CJ-4 or CK-4

- Fuel:**
- Use the ultra low sulfur diesel fuel only [below 0.0015% (15 ppm)] for these engines.
 - Cetane number of 45 is minimum. Cetane number greater than 50 is preferred, especially for temperatures below -20 °C (-4 °F) or elevations above 1500 m (5000 ft).
 - Diesel fuels specified to **EN 590** or **ASTM D975** are recommended.
 - **No.2-D** is a distillate fuel of lower volatility for engines in industrial and heavy mobile service. (**SAE J313 JUN87**)
 - Indicated capacities of water and oil are manufacture's estimate.

- IMPORTANT :**
- **If you use different fuel or engine oil, the cleaning efficiency of the DPF will be reduced and the DPF longevity will be shorter than expected.**
 - **Filters must trap fuel and lubricant sulfate additives (Zn, Pb, Na, K, Ca, Mg, Cu, Ba, P, and so on.) as ash during combustion. Fuel must be controlled carefully to prevent the additives being mixed into fuel such as fuel tank anti-oxidants, water remover, antifreeze and so on.**

BIODIESEL FUEL (BDF)

B0-B20 Biodiesel fuels (BDF): mixed diesel fuels containing 20 % or less biodiesel can be utilized under the following conditions.

IMPORTANT :

- **Refueling and handling fuel should be done with caution in order to avoid contact with the fuel and spillage that could create a potential environmental or fire hazard. Wear appropriate protective equipment when refueling.**

Applicable BDF:

- Blended diesel fuels containing 6 % through 20 % BDF (B6 - B20) which comply with American Society for Testing and Materials (ASTM) D7467 Standard, as revised, can be used without adversely affecting the performance and durability of the engine and fuel system components.
- Any mineral oil diesel fuel, if used, must conform to ASTM D975 (or the European EN590) Standard, as revised. B100 fuel used to make Biodiesel blended fuels must meet ASTM D6751 (or EN14214) Standard, as revised. The final blended fuel B20 must conform to ASTM D7467 Standard, as revised. Straight vegetable oil is not allowed in any blended fuel.
- Allowable blended fuel is mineral oil diesel fuel blended with B100 (meaning, 100 % BDF). The blended fuel ratio shall be less than 20 % B100 and 80 % or more diesel fuel. The B100 source used for Biodiesel blends must be purchased from an accredited BQ-9000 marketer or producer. More information about qualified marketer(s) and producer(s) can be found at <http://www.bq-9000.org>.

Preparation:

- Before using BDF concentrations greater than B5, you are advised to replace the engine oil, engine oil filter and fuel filter with new oil and filters. Details regarding the replacement procedures can be found in a different section. (See Changing the engine oil on page 137 and Replacing the engine oil filter cartridge on page 138.)

Product warranty, emission and other precautions:

- The engine emission control system was certified according to current regulations based on the use of non-BDF. When using BDF, the owner is advised to check applicable local and federal emission regulations and comply with all of them.
- BDF may cause restricted or clogged fuel filters during cold weather conditions, resulting in the engine not operating properly.
- BDF encourages the growth of microorganisms which may cause degradation of the fuel. This in turn may cause fuel line corrosion or reduce fuel filter flow earlier than expected.
- BDF inherently absorbs moisture which may cause degradation of the fuel earlier than expected. To avoid this, drain the water separator and fuel filter port often.
- Do not use Biodiesel concentrations higher than 20 % (namely, greater than B20). Engine performance and fuel consumption will be affected, and degradation of the fuel system components may occur.
- Do not readjust the engine fuel control system as this will violate emission control levels for which the equipment was approved.
- Compared with soybean-based and rapeseed-based feedstock, palm oil-based feedstock has a thicker consistency (that is, higher viscosity) at lower temperatures. Consequently, fuel filter performance may be reduced, particularly during cold weather conditions.
- The Kubota Warranty, as specified in the owner's warranty information guide, only covers defects in product materials and workmanship. Accordingly, any problems that may arise due to the use of poor quality fuels that fail to meet the above requirements, whether biodiesel or mineral oil based, are not covered by the Kubota Warranty.

Routine handling:

- Avoid spilling BDF onto painted surfaces as this may damage the finish. If fuel is spilled immediately wipe clean and flush with soapy water to avoid permanent damage.
- When using BDF, you are advised to maintain a full tank of fuel, especially overnight and during short term storage, to reduce condensation within the tank. Tighten the fuel cap after refueling to prevent moisture build up within the tank. Water in the biodiesel mixture will damage fuel filters and may damage engine components.

Maintenance requirements when using BDF B0 through B5:

Follow the recommended oil change intervals. (See MAINTENANCE INTERVALS on page 111.)

Extended oil change intervals may result in premature wear or engine damage.

RECOMMENDED OILS AND FUELS

Maintenance requirements when using BDF B6 through B20:

The maintenance intervals for fuel related parts changes.

See the following table for the new maintenance intervals.

Items		Interval	Remarks
Water separator filter element	Replace	Every 250 hrs	
Fuel filter cartridge	Replace	Every 250 hrs	
Fuel line	Check	Every 100 hrs	
	Replace	Every 1 year	Contact your local Kubota dealer for this service.

Long term storage:

- BDF easily deteriorates due to oxygen, water, heat and foreign substances.
Do not store B6 through B20 longer than 1 month and B5 longer than 3 months.
- When using B6 through B20 and storing the machine longer than 1 month, drain the fuel from the tanks and replace with light mineral oil diesel fuel.
Subsequently, run the engine at least 30 minutes to remove all of the Biodiesel from the fuel lines.
- When using B5 fuel and storing machine longer than 3 months, drain the fuel from the tanks and replace with light mineral oil diesel fuel.
Subsequently, run the engine at least 30 minutes to remove all of the Biodiesel from the fuel lines.

REQUEST REGARDING FUEL USE AND MAINTENANCE OF CRS DIESEL ENGINES

Please use fuel and perform maintenance as directed in this operator's manual.

Use quality fuel (diesel) that meets the exhaust gas regulations for the region where the engine is used. Particular attention should be given to contamination and sulfur content in the fuel.

- Kubota CRS diesel engines are equipped with an electronically controlled high-pressure fuel injection system (CRS: Common Rail System) and an exhaust emission control system (DPF: Diesel Particulate Filter) in order for the engines to perform satisfactorily and to meet required emission characteristics.
- The electronically controlled high-pressure fuel injection system is made up of high precision components. If the fuel gets contaminated with foreign matters, the system may malfunction or very adversely affected for its service life. If the sulfur content is higher than approved, the product service life may be reduced. It includes the early deterioration of engine oil, the wear of engine components and the catalyst degradation of the exhaust emission control system.

Country	Standard name	Sulfur content reference value	Remarks
Europe	EN590	0.0010 % (10 ppm) or less	-
North America	ASTM D975	0.0015 % (15 ppm) or less	-
Japan	JIS K2204	0.0010 % (10 ppm) or less	-
Australia	Australian Standard	0.0010 % (10 ppm) or less	-
Republic of Korea	Korean Standard	0.0010 % (10 ppm) or less	-
China	GB 252	0.0050 % (50 ppm) or less	From July 1, 2017
		0.0010 % (10 ppm) or less	From January 1, 2018

Handle fuel, fuel tank and fuel filter with enough care to keep them free of foreign matters.

- Do not use any fuel that is contaminated with dust and the like.
- Do not refuel the machine nor replace the filter in any dusty environments.
- During refueling, be careful to prevent foreign matters from coming into the fuel tank.
- Before replacing the filter, clean up its periphery.
- Do not interrupt the replacement job. This is to keep the filter and its periphery free of foreign matters.
- For the job, wear clean vinyl or similar gloves. Cotton work gloves and other fiber gloves may cause contamination.

Use only Kubota brand parts. Perform maintenance in accordance with instructions from Kubota.

- Inspect and replace the water separator and fuel filter at regular intervals in accordance with the instructions provided by Kubota.
- If any other water separators and fuel filters than Kubota brands are used and if the specified servicing instructions are neglected, malfunctions similar to those in Item 1 above may occur, leading to engine breakdown.

The following cases are not covered by the warranty. Kubota will not be responsible for any burden of expenses.

- If the engine fails because of the use of any fuel and/or fuel filter not recommended by Kubota or because of the negligence of specified servicing instructions, the end user will be responsible for all costs.

APPENDICES

MAIN DIMENSIONS

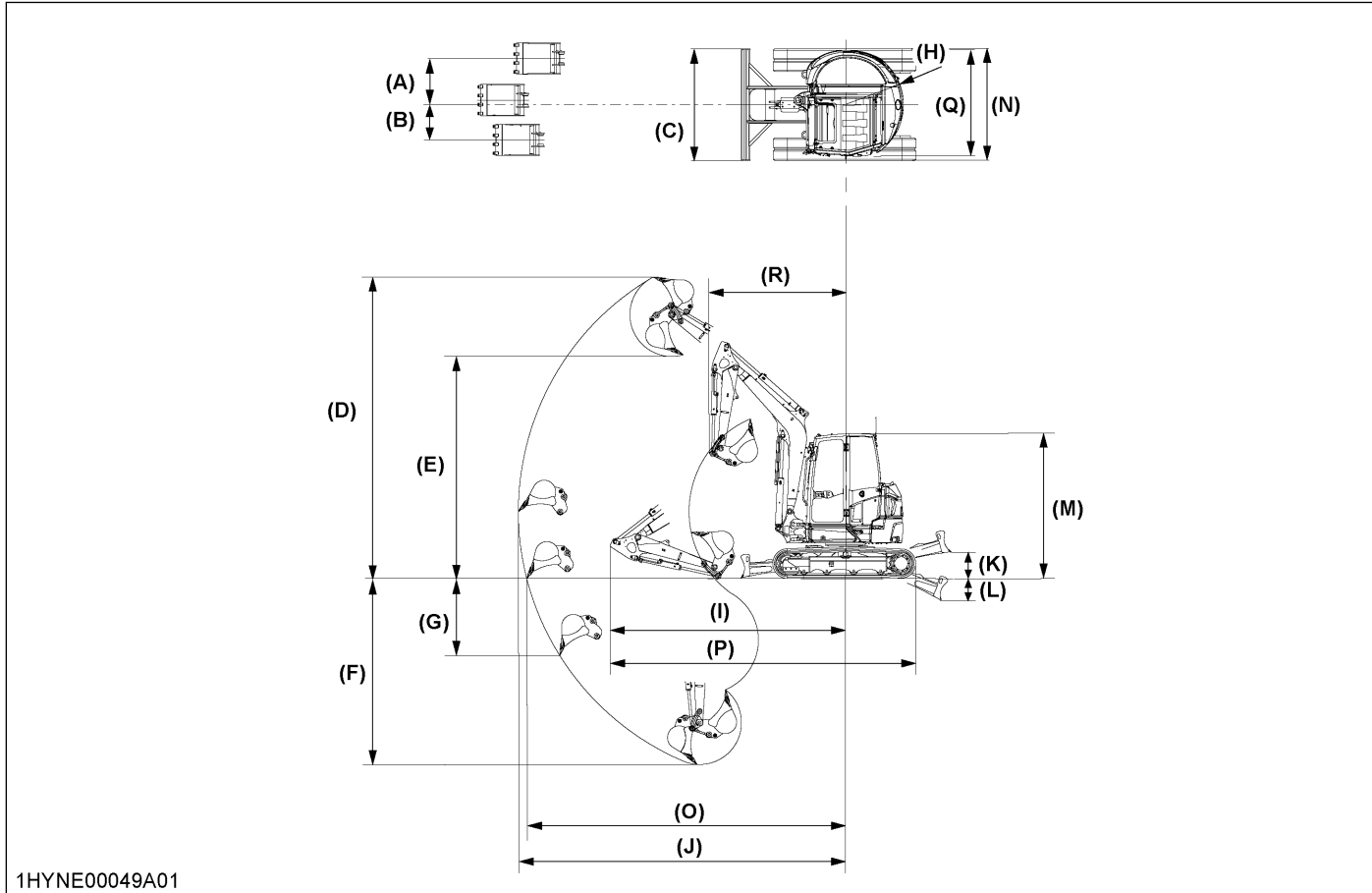

	(A)	(B)	(C)	(D)	(E)	(F)	(G)	(H)	(I)	(J)
Standard blade			1700 (66.93)							
Angle blade	575 (22.6)	395 (15.6)	1700 (66.93)	5335 (210.0)	3900 (153.5)	3410 (134.3)	2385 (93.9)	1300 (51.18)	3785 (149.0)	5535 (217.9)
6-in-1 blade			1800 (70.87)							

	(K)	(L)	(M) Canopy	(M) CAB	(N)	(O)	(P)	(Q)	(R)
Standard blade	400 (15.7)	405 (15.9)							
Angle blade	420 (16.5)	510 (20.1)	2480 (97.64)	2490 (98.03)	1700 (66.93)	5400 (212.6)	5085 (200.2)	1700 (66.93)	2155 (84.84)
6-in-1 blade	433 (17.0)	527 (20.7)							

NOTE :

- Above dimensions are based on the machine with quick attach coupler (K7870A) and quick attach bucket (K7875A).
- Above dimensions are based on the machine with a rubber track.
- Specifications are subject to change without notice.

LIFTING CAPACITY

IMPORTANT INFORMATION

WARNING

To avoid personal injury or death:

- Do not lift loads greater than those values mentioned in the lifting capacity tables.
 - The values mentioned in the table are valid only on even, hard ground. When lifting on soft ground, the machine can roll over due to the load being concentrated only on one side of the machine.
 - The table values are calculated at the end of the arm without the bucket. In order to find the allowable loads for machines with a bucket, subtract the bucket weight from the values in the table.
 - Never lift the machine with the angle blade placed at an angle.
1. The lifting capacities are based on **ISO 10567** and do not exceed 75 % of the static tilt load of the machine or 87 % of the hydraulic lifting capacity of the machine.
 2. The strokes are as follows:
 - a. The load point corresponds to the front bolt part of the arm.
 - b. The machine positions are
 - i. over - front (blade down)
 - ii. over - front (blade up)
 - iii. over - side
 - c. The operating cylinder is the boom cylinder.
 3. The bucket of the machine, the hook, the sling, and other lifting accessories are taken into consideration for the loads.
The following illustration shows machine condition without the bucket and all the other conditions are according to standard regulations.

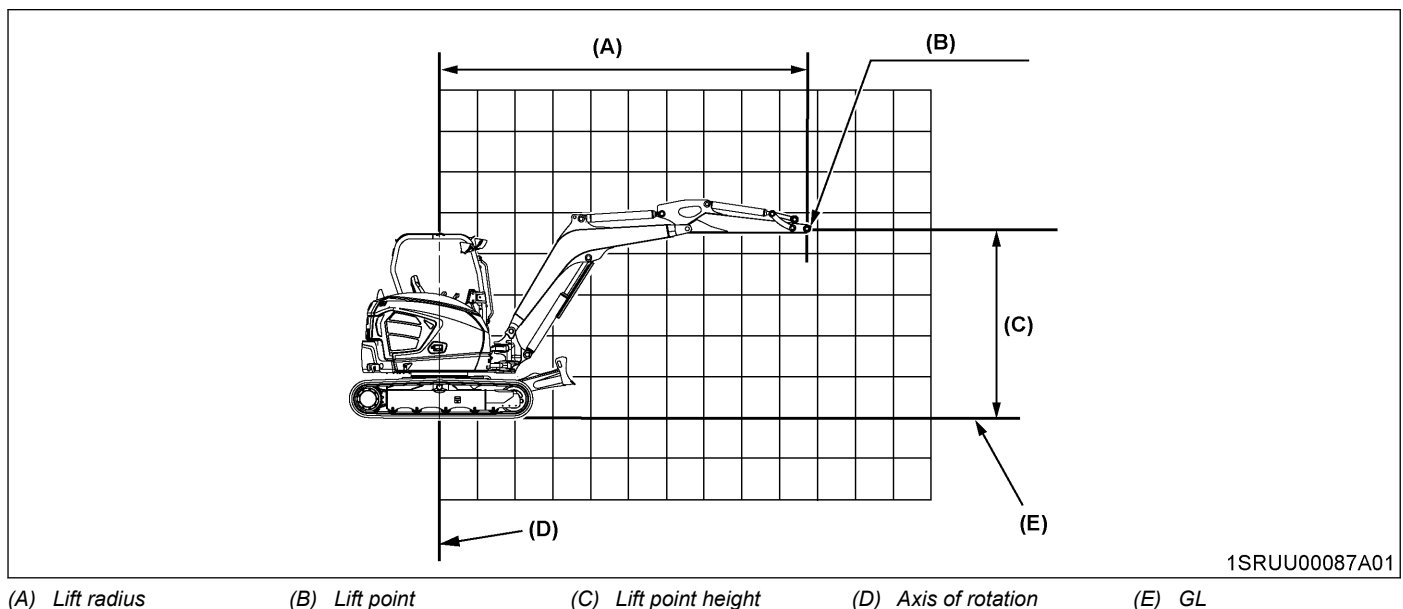

LIFTING CAPACITY OF (CANOPY, RUBBER TRACK, STANDARD BLADE)

Lifting capacity over-end blade down

Lift point height (ft)	Load radius (ft)									
	Min.	2	4	6	8	10	12	14	Max.	
GL	14									
	12						1.58			
	10						1.58	1.64	1.66	
	8					1.79	1.70	1.66	1.67	
	6				2.71	2.18	1.91	1.75	1.69	
	4				3.56	2.60	2.14	1.87	1.72	
	2				4.13	2.94	2.33	1.98	1.76	
	0			2.46	4.31	3.12	2.45	2.03	1.80	
	-2	2.15	1.99	2.73	3.82	4.22	3.13	2.45	1.97	1.84
	-4	3.28	2.77	4.13	5.55	3.90	2.94	2.28		
	-6			5.90	4.55	3.28	2.46			
	-8				2.88	2.07				

Unit=1000 lbs

Lifting capacity over-end blade up

Lift point height (ft)	Load radius (ft)									
	Min.	2	4	6	8	10	12	14	Max.	
GL	14									
	12						1.58			
	10						1.58	1.42	1.38	
	8					1.79	1.70	1.41	1.26	
	6				2.71	2.18	1.76	1.39	1.19	
	4				3.14	2.24	1.72	1.37	1.16	
	2				3.05	2.18	1.68	1.35	1.16	
	0			2.46	3.01	2.15	1.66	1.34	1.20	
	-2	2.15	1.99	2.73	3.82	3.01	2.14	1.65	1.34	1.29
	-4	3.28	2.77	4.13	5.05	3.02	2.15	1.66		
	-6			5.90	4.55	3.08	2.19			
	-8				2.88	3.07				

Unit=1000 lbs

Lifting capacity over-side

Lift point height (ft)	Load radius (ft)									
	Min.	2	4	6	8	10	12	14	Max.	
GL	14									
	12						1.58			
	10						1.58	1.26	1.23	
	8					1.79	1.59	1.26	1.12	
	6				2.71	2.03	1.55	1.24	1.06	
	4				2.71	1.96	1.52	1.22	1.03	
	2				2.62	1.91	1.49	1.20	1.03	
	0			2.46	2.59	1.88	1.46	1.19	1.06	
	-2	2.15	1.99	2.73	3.82	2.58	1.87	1.46	1.19	1.14
	-4	3.28	2.77	4.13	4.17	2.60	1.88	1.47		
	-6			5.90	4.24	2.65	1.91			
	-8				2.88	2.07				

Unit=1000 lbs

LIFTING CAPACITY OF (CANOPY, STEEL TRACK, STANDARD BLADE)

Lifting capacity over-end blade down

Lift point height (ft)	Load radius (ft)									
	Min.	2	4	6	8	10	12	14	Max.	
GL	14									
	12						1.58			
	10						1.58	1.64	1.66	
	8					1.79	1.70	1.66	1.67	
	6				2.71	2.18	1.91	1.75	1.69	
	4				3.56	2.60	2.14	1.87	1.72	
	2				4.13	2.94	2.33	1.98	1.76	
	0				2.46	4.31	3.12	2.45	2.03	1.80
	-2	2.15	1.99	2.73	3.82	4.22	3.13	2.45	1.97	1.84
	-4	3.28	2.77	4.13	5.55	3.90	2.94	2.28		
	-6			5.90	4.55	3.28	2.46			
	-8				2.88	2.07				

Unit=1000 lbs

Lifting capacity over-end blade up

Lift point height (ft)	Load radius (ft)									
	Min.	2	4	6	8	10	12	14	Max.	
GL	14									
	12						1.58			
	10						1.58	1.44	1.41	
	8					1.79	1.70	1.43	1.28	
	6				2.71	2.18	1.78	1.42	1.21	
	4				3.20	2.28	1.75	1.40	1.18	
	2				3.10	2.22	1.71	1.38	1.18	
	0				2.46	3.06	2.19	1.69	1.37	1.22
	-2	2.15	1.99	2.73	3.82	3.06	2.18	1.68	1.37	1.31
	-4	3.28	2.77	4.13	5.13	3.08	2.19	1.69		
	-6			5.90	4.55	3.13	2.22			
	-8				2.88	2.07				

Unit=1000 lbs

Lifting capacity over-side

Lift point height (ft)	Load radius (ft)									
	Min.	2	4	6	8	10	12	14	Max.	
GL	14									
	12						1.57			
	10						1.56	1.23	1.20	
	8					1.79	1.54	1.22	1.09	
	6				2.71	1.97	1.51	1.20	1.03	
	4				2.61	1.90	1.47	1.18	1.00	
	2				2.52	1.85	1.44	1.17	1.00	
	0				2.46	2.49	1.82	1.42	1.15	1.03
	-2	2.15	1.99	2.73	3.82	2.49	1.81	1.41	1.16	1.11
	-4	3.28	2.77	4.13	3.98	2.51	1.82	1.42		
	-6			5.90	4.05	2.55	1.85			
	-8				2.88	2.07				

Unit=1000 lbs

LIFTING CAPACITY OF (CANOPY, RUBBER TRACK, ANGLE BLADE)

Lifting capacity over-end blade down

Lift point height (ft)	Load radius (ft)									
	Min.	2	4	6	8	10	12	14	Max.	
GL	14									
	12						1.58			
	10						1.58	1.64	1.66	
	8						1.79	1.70	1.66	1.67
	6					2.71	2.18	1.91	1.75	1.69
	4					3.56	2.60	2.14	1.87	1.72
	2					4.13	2.94	2.33	1.98	1.76
	0				2.46	4.31	3.12	2.45	2.03	1.80
	-2	2.15	1.99	2.73	3.82	4.22	3.13	2.45	1.97	1.84
	-4	3.28	2.77	4.13	5.55	3.90	2.94	2.28		
	-6			5.90	4.55	3.28	2.46			
	-8				2.88	2.07				

Unit=1000 lbs

Lifting capacity over-end blade up

Lift point height (ft)	Load radius (ft)									
	Min.	2	4	6	8	10	12	14	Max.	
GL	14									
	12							1.58		
	10							1.58	1.37	1.34
	8						1.79	1.70	1.37	1.22
	6					2.71	2.18	1.70	1.35	1.15
	4					3.05	2.17	1.66	1.33	1.12
	2					2.96	2.12	1.63	1.31	1.12
	0				2.46	2.92	2.08	1.61	1.30	1.16
	-2	2.15	1.99	2.73	3.82	2.92	2.07	1.60	1.30	1.24
	-4	3.28	2.77	4.13	4.90	2.94	2.09	1.61		
	-6			5.90	4.55	2.98	2.12			
	-8				2.88	2.07				

Unit=1000 lbs

Lifting capacity over-side

Lift point height (ft)	Load radius (ft)									
	Min.	2	4	6	8	10	12	14	Max.	
GL	14									
	12						1.58			
	10						1.58	1.32	1.29	
	8						1.79	1.66	1.32	1.17
	6					2.71	2.13	1.63	1.30	1.11
	4					2.84	2.06	1.59	1.28	1.08
	2					2.75	2.00	1.56	1.26	1.08
	0				2.46	2.71	1.97	1.54	1.25	1.12
	-2	2.15	1.99	2.73	3.82	2.71	1.96	1.53	1.25	1.20
	-4	3.28	2.77	4.13	4.38	2.73	1.97	1.54		
	-6			5.90	4.44	2.77	2.01			
	-8				2.88	2.07				

Unit=1000 lbs

LIFTING CAPACITY OF (CANOPY, STEEL TRACK, ANGLE BLADE)

Lifting capacity over-end blade down

Lift point height (ft)	Load radius (ft)									
	Min.	2	4	6	8	10	12	14	Max.	
GL	14									
	12						1.58			
	10						1.58	1.64	1.66	
	8						1.79	1.70	1.66	1.67
	6					2.71	2.18	1.91	1.75	1.69
	4					3.56	2.60	2.14	1.87	1.72
	2					4.13	2.94	2.33	1.98	1.76
	0				2.46	4.31	3.12	2.45	2.03	1.80
	-2	2.15	1.99	2.73	3.82	4.22	3.13	2.45	1.97	1.84
	-4	3.28	2.77	4.13	5.55	3.90	2.94	2.28		
	-6			5.90	4.55	3.28	2.46			
	-8				2.88	2.07				

Unit=1000 lbs

Lifting capacity over-end blade up

Lift point height (ft)	Load radius (ft)									
	Min.	2	4	6	8	10	12	14	Max.	
GL	14									
	12							1.58		
	10							1.58	1.40	1.36
	8						1.79	1.70	1.39	1.24
	6					2.71	2.18	1.73	1.37	1.17
	4					3.10	2.21	1.69	1.35	1.14
	2					3.01	2.15	1.66	1.34	1.14
	0				2.46	2.97	2.12	1.64	1.32	1.18
	-2	2.15	1.99	2.73	3.82	2.97	2.11	1.63	1.32	1.27
	-4	3.28	2.77	4.13	4.98	2.99	2.12	1.64		
	-6			5.90	4.55	3.04	2.16			
	-8				2.88	2.07				

Unit=1000 lbs

Lifting capacity over-side

Lift point height (ft)	Load radius (ft)									
	Min.	2	4	6	8	10	12	14	Max.	
GL	14									
	12						1.58			
	10						1.58	1.28	1.25	
	8						1.79	1.61	1.28	1.14
	6					2.71	2.06	1.58	1.26	1.08
	4					2.73	1.99	1.54	1.24	1.05
	2					2.64	1.94	1.51	1.22	1.05
	0				2.46	2.61	1.91	1.49	1.21	1.09
	-2	2.15	1.99	2.73	3.82	2.61	1.90	1.48	1.21	1.16
	-4	3.28	2.77	4.13	4.17	2.63	1.91	1.49		
	-6			5.90	4.24	2.67	1.94			
	-8				2.88	2.07				

Unit=1000 lbs

LIFTING CAPACITY OF (CANOPY, RUBBER TRACK, 6-IN-1 BLADE)

Lifting capacity over-end blade down

Lift point height (ft)	Load radius (ft)									
	Min.	2	4	6	8	10	12	14	Max.	
GL	14									
	12						1.58			
	10						1.58	1.64	1.66	
	8						1.79	1.70	1.66	1.67
	6					2.71	2.18	1.91	1.75	1.69
	4					3.56	2.60	2.14	1.87	1.72
	2					4.13	2.94	2.33	1.98	1.76
	0				2.46	4.31	3.12	2.45	2.03	1.80
	-2	2.15	1.99	2.73	3.82	4.22	3.13	2.45	1.97	1.84
	-4	3.28	2.77	4.13	5.55	3.90	2.94	2.28		
	-6			5.90	4.55	3.28	2.46			
	-8				2.88	2.07				

Unit=1000 lbs

Lifting capacity over-end blade up

Lift point height (ft)	Load radius (ft)									
	Min.	2	4	6	8	10	12	14	Max.	
GL	14									
	12						1.58			
	10						1.58	1.33	1.30	
	8						1.79	1.69	1.33	1.18
	6					2.71	2.18	1.65	1.31	1.11
	4					2.96	2.11	1.61	1.29	1.08
	2					2.87	2.05	1.58	1.27	1.09
	0				2.46	2.83	2.02	1.56	1.26	1.12
	-2	2.15	1.99	2.73	3.82	2.83	2.01	1.55	1.26	1.20
	-4	3.28	2.77	4.13	4.75	2.85	2.02	1.56		
	-6			5.90	4.55	2.89	2.06			
	-8				2.88	2.07				

Unit=1000 lbs

Lifting capacity over-side

Lift point height (ft)	Load radius (ft)									
	Min.	2	4	6	8	10	12	14	Max.	
GL	14									
	12						1.58			
	10						1.58	1.37	1.34	
	8						1.79	1.70	1.37	1.22
	6					2.71	2.18	1.69	1.35	1.15
	4					2.94	2.13	1.65	1.33	1.12
	2					2.85	2.08	1.62	1.31	1.13
	0				2.46	2.81	2.05	1.60	1.30	1.16
	-2	2.15	1.99	2.73	3.82	2.81	2.04	1.59	1.30	1.25
	-4	3.28	2.77	4.13	4.53	2.83	2.05	1.60		
	-6			5.90	4.55	2.87	2.08			
	-8				2.88	2.07				

Unit=1000 lbs

LIFTING CAPACITY OF (CANOPY, STEEL TRACK, 6-IN-1 BLADE)

Lifting capacity over-end blade down

Lift point height (ft)	Load radius (ft)									
	Min.	2	4	6	8	10	12	14	Max.	
GL	14									
	12						1.58			
	10						1.58	1.64	1.66	
	8					1.79	1.70	1.66	1.67	
	6				2.71	2.18	1.91	1.75	1.69	
	4				3.56	2.60	2.14	1.87	1.72	
	2				4.13	2.94	2.33	1.98	1.76	
	0				2.46	4.31	3.12	2.45	2.03	1.80
	-2	2.15	1.99	2.73	3.82	4.22	3.13	2.45	1.97	1.84
	-4	3.28	2.77	4.13	5.55	3.90	2.94	2.28		
	-6			5.90	4.55	3.28	2.46			
	-8				2.88	2.07				

Unit=1000 lbs

Lifting capacity over-end blade up

Lift point height (ft)	Load radius (ft)									
	Min.	2	4	6	8	10	12	14	Max.	
GL	14									
	12						1.58			
	10						1.58	1.36	1.32	
	8					1.79	1.70	1.35	1.20	
	6				2.71	2.18	1.68	1.33	1.13	
	4				3.01	2.15	1.64	1.31	1.10	
	2				2.92	2.09	1.61	1.29	1.11	
	0				2.46	2.88	2.06	1.59	1.28	1.14
	-2	2.15	1.99	2.73	3.82	2.88	2.05	1.58	1.28	1.23
	-4	3.28	2.77	4.13	4.84	2.90	2.06	1.59		
	-6			5.90	4.55	2.95	2.09			
	-8				2.88	2.07				

Unit=1000 lbs

Lifting capacity over-side

Lift point height (ft)	Load radius (ft)									
	Min.	2	4	6	8	10	12	14	Max.	
GL	14									
	12						1.58			
	10						1.58	1.33	1.30	
	8					1.79	1.67	1.32	1.18	
	6				2.71	2.13	1.63	1.31	1.12	
	4				2.82	2.06	1.60	1.29	1.09	
	2				2.74	2.01	1.56	1.27	1.09	
	0				2.46	2.70	1.97	1.54	1.26	1.13
	-2	2.15	1.99	2.73	3.82	2.70	1.97	1.54	1.26	1.21
	-4	3.28	2.77	4.13	4.32	2.72	1.98	1.55		
	-6			5.90	4.38	2.76	2.01			
	-8				2.88	2.07				

Unit=1000 lbs

LIFTING CAPACITY OF (CAB, RUBBER TRACK, STANDARD BLADE)

Lifting capacity over-end blade down

Lift point height (ft)	Load radius (ft)									
	Min.	2	4	6	8	10	12	14	Max.	
GL	14									
	12						1.58			
	10						1.58	1.64	1.66	
	8						1.79	1.70	1.66	1.67
	6					2.71	2.18	1.91	1.75	1.69
	4					3.56	2.60	2.14	1.87	1.72
	2					4.13	2.94	2.33	1.98	1.76
	0				2.46	4.31	3.12	2.45	2.03	1.80
	-2	2.15	1.99	2.73	3.82	4.22	3.13	2.45	1.97	1.84
	-4	3.28	2.77	4.13	5.55	3.90	2.94	2.28		
	-6			5.90	4.55	3.28	2.46			
	-8				2.88	2.07				

Unit=1000 lbs

Lifting capacity over-end blade up

Lift point height (ft)	Load radius (ft)									
	Min.	2	4	6	8	10	12	14	Max.	
GL	14									
	12						1.58			
	10						1.58	1.48	1.44	
	8						1.79	1.70	1.47	1.31
	6					2.71	2.18	1.83	1.45	1.24
	4					3.28	2.34	1.79	1.43	1.21
	2					3.18	2.28	1.76	1.42	1.21
	0				2.46	3.14	2.25	1.73	1.40	1.25
	-2	2.15	1.99	2.73	3.82	3.14	2.24	1.73	1.40	1.34
	-4	3.28	2.77	4.13	5.26	3.16	2.25	1.74		
	-6			5.90	4.55	3.21	2.28			
	-8				2.88	2.07				

Unit=1000 lbs

Lifting capacity over-side

Lift point height (ft)	Load radius (ft)									
	Min.	2	4	6	8	10	12	14	Max.	
GL	14									
	12						1.58			
	10						1.58	1.31	1.28	
	8						1.79	1.65	1.31	1.17
	6					2.71	2.11	1.62	1.29	1.10
	4					2.82	2.04	1.58	1.27	1.07
	2					2.73	1.99	1.55	1.25	1.08
	0				2.46	2.69	1.96	1.53	1.24	1.11
	-2	2.15	1.99	2.73	3.82	2.69	1.95	1.52	1.24	1.19
	-4	3.28	2.77	4.13	4.35	2.71	1.96	1.53		
	-6			5.90	4.41	2.76	1.99			
	-8				2.88	2.07				

Unit=1000 lbs

LIFTING CAPACITY OF (CAB, STEEL TRACK, STANDARD BLADE)

Lifting capacity over-end blade down

Lift point height (ft)	Load radius (ft)									
	Min.	2	4	6	8	10	12	14	Max.	
GL	14									
	12						1.58			
	10						1.58	1.64	1.66	
	8					1.79	1.70	1.66	1.67	
	6				2.71	2.18	1.91	1.75	1.69	
	4				3.56	2.60	2.14	1.87	1.72	
	2				4.13	2.94	2.33	1.98	1.76	
	0				2.46	4.31	3.12	2.45	2.03	1.80
	-2	2.15	1.99	2.73	3.82	4.22	3.13	2.45	1.97	1.84
	-4	3.28	2.77	4.13	5.55	3.90	2.94	2.28		
	-6			5.90	4.55	3.28	2.46			
	-8				2.88	2.07				

Unit=1000 lbs

Lifting capacity over-end blade up

Lift point height (ft)	Load radius (ft)									
	Min.	2	4	6	8	10	12	14	Max.	
GL	14									
	12						1.58			
	10						1.58	1.50	1.47	
	8					1.79	1.70	1.50	1.33	
	6				2.71	2.18	1.86	1.48	1.26	
	4				3.33	2.37	1.82	1.46	1.23	
	2				3.23	2.31	1.79	1.44	1.23	
	0				2.46	3.19	2.28	1.76	1.43	1.27
	-2	2.15	1.99	2.73	3.82	3.19	2.27	1.76	1.43	1.37
	-4	3.28	2.77	4.13	5.35	3.21	2.28	1.77		
	-6			5.90	4.55	3.26	2.32			
	-8				2.88	2.07				

Unit=1000 lbs

Lifting capacity over-side

Lift point height (ft)	Load radius (ft)									
	Min.	2	4	6	8	10	12	14	Max.	
GL	14									
	12						1.58			
	10						1.58	1.28	1.25	
	8					1.79	1.60	1.27	1.13	
	6				2.71	2.04	1.57	1.25	1.07	
	4				2.71	1.98	1.53	1.23	1.04	
	2				2.63	1.92	1.50	1.22	1.04	
	0				2.46	2.59	1.89	1.48	1.21	1.08
	-2	2.15	1.99	2.73	3.82	2.59	1.88	1.47	1.21	1.16
	-4	3.28	2.77	4.13	4.14	2.61	1.89	1.48		
	-6			5.90	4.21	2.65	1.93			
	-8				2.88	2.07				

Unit=1000 lbs

LIFTING CAPACITY OF (CAB, RUBBER TRACK, ANGLE BLADE)

Lifting capacity over-end blade down

Lift point height (ft)	Load radius (ft)									
	Min.	2	4	6	8	10	12	14	Max.	
GL	14									
	12						1.58			
	10						1.58	1.64	1.66	
	8						1.79	1.70	1.66	1.67
	6					2.71	2.18	1.91	1.75	1.69
	4					3.56	2.60	2.14	1.87	1.72
	2					4.13	2.94	2.33	1.98	1.76
	0				2.46	4.31	3.12	2.45	2.03	1.80
	-2	2.15	1.99	2.73	3.82	4.22	3.13	2.45	1.97	1.84
	-4	3.28	2.77	4.13	5.55	3.90	2.94	2.28		
	-6			5.90	4.55	3.28	2.46			
	-8				2.88	2.07				

Unit=1000 lbs

Lifting capacity over-end blade up

Lift point height (ft)	Load radius (ft)									
	Min.	2	4	6	8	10	12	14	Max.	
GL	14									
	12						1.58			
	10						1.58	1.43	1.40	
	8						1.79	1.70	1.43	1.27
	6					2.71	2.18	1.78	1.41	1.20
	4					3.18	2.27	1.74	1.39	1.17
	2					3.09	2.21	1.70	1.37	1.17
	0				2.46	3.05	2.18	1.68	1.36	1.21
	-2	2.15	1.99	2.73	3.82	3.05	2.17	1.67	1.36	1.30
	-4	3.28	2.77	4.13	5.11	3.07	2.18	1.68		
	-6			5.90	4.55	3.11	2.21			
	-8				2.88	2.07				

Unit=1000 lbs

Lifting capacity over-side

Lift point height (ft)	Load radius (ft)									
	Min.	2	4	6	8	10	12	14	Max.	
GL	14									
	12						1.58			
	10						1.58	1.38	1.34	
	8						1.79	1.70	1.37	1.22
	6					2.71	2.18	1.69	1.35	1.16
	4					2.95	2.14	1.65	1.33	1.13
	2					2.86	2.08	1.62	1.32	1.13
	0				2.46	2.82	2.05	1.60	1.30	1.17
	-2	2.15	1.99	2.73	3.82	2.82	2.04	1.59	1.30	1.25
	-4	3.28	2.77	4.13	4.54	2.84	2.05	1.60		
	-6			5.90	4.55	2.88	2.09			
	-8				2.88	2.07				

Unit=1000 lbs

LIFTING CAPACITY OF (CAB, STEEL TRACK, ANGLE BLADE)

Lifting capacity over-end blade down

Lift point height (ft)	Load radius (ft)									
	Min.	2	4	6	8	10	12	14	Max.	
GL	14									
	12						1.58			
	10						1.58	1.64	1.66	
	8					1.79	1.70	1.66	1.67	
	6				2.71	2.18	1.91	1.75	1.69	
	4				3.56	2.60	2.14	1.87	1.72	
	2				4.13	2.94	2.33	1.98	1.76	
	0				2.46	4.31	3.12	2.45	2.03	1.80
	-2	2.15	1.99	2.73	3.82	4.22	3.13	2.45	1.97	1.84
	-4	3.28	2.77	4.13	5.55	3.90	2.94	2.28		
	-6			5.90	4.55	3.28	2.46			
	-8				2.88	2.07				

Unit=1000 lbs

Lifting capacity over-end blade up

Lift point height (ft)	Load radius (ft)									
	Min.	2	4	6	8	10	12	14	Max.	
GL	14									
	12						1.58			
	10						1.58	1.46	1.42	
	8					1.79	1.70	1.45	1.29	
	6				2.71	2.18	1.80	1.43	1.22	
	4				3.23	2.30	1.77	1.41	1.19	
	2				3.14	2.25	1.73	1.40	1.19	
	0				2.46	3.10	2.21	1.71	1.38	1.23
	-2	2.15	1.99	2.73	3.82	3.10	2.20	1.70	1.38	1.32
	-4	3.28	2.77	4.13	5.19	3.12	2.22	1.71		
	-6			5.90	4.55	3.16	2.25			
	-8				2.88	2.07				

Unit=1000 lbs

Lifting capacity over-side

Lift point height (ft)	Load radius (ft)									
	Min.	2	4	6	8	10	12	14	Max.	
GL	14									
	12						1.58			
	10						1.58	1.33	1.30	
	8					1.79	1.67	1.33	1.19	
	6				2.71	2.13	1.64	1.31	1.12	
	4				2.83	2.07	1.60	1.29	1.09	
	2				2.75	2.01	1.57	1.27	1.10	
	0				2.46	2.71	1.98	1.55	1.26	1.13
	-2	2.15	1.99	2.73	3.82	2.71	1.97	1.54	1.26	1.21
	-4	3.28	2.77	4.13	4.33	2.73	1.98	1.55		
	-6			5.90	4.40	2.77	2.02			
	-8				2.88	2.07				

Unit=1000 lbs

LIFTING CAPACITY OF (CAB, RUBBER TRACK, 6-IN-1 BLADE)

Lifting capacity over-end blade down

Lift point height (ft)	Load radius (ft)									
	Min.	2	4	6	8	10	12	14	Max.	
GL	14									
	12						1.58			
	10						1.58	1.64	1.66	
	8						1.79	1.70	1.66	1.67
	6					2.71	2.18	1.91	1.75	1.69
	4					3.56	2.60	2.14	1.87	1.72
	2					4.13	2.94	2.33	1.98	1.76
	0				2.46	4.31	3.12	2.45	2.03	1.80
	-2	2.15	1.99	2.73	3.82	4.22	3.13	2.45	1.97	1.84
	-4	3.28	2.77	4.13	5.55	3.90	2.94	2.28		
	-6			5.90	4.55	3.28	2.46			
	-8				2.88	2.07				

Unit=1000 lbs

Lifting capacity over-end blade up

Lift point height (ft)	Load radius (ft)									
	Min.	2	4	6	8	10	12	14	Max.	
GL	14									
	12						1.58			
	10						1.58	1.39	1.36	
	8						1.79	1.70	1.39	1.23
	6					2.71	2.18	1.72	1.37	1.16
	4					3.09	2.20	1.69	1.35	1.13
	2					3.00	2.15	1.65	1.33	1.14
	0				2.46	2.96	2.11	1.63	1.32	1.18
	-2	2.15	1.99	2.73	3.82	2.96	2.10	1.62	1.32	1.26
	-4	3.28	2.77	4.13	4.96	2.98	2.11	1.63		
	-6			5.90	4.55	3.02	2.15			
	-8				2.88	2.07				

Unit=1000 lbs

Lifting capacity over-side

Lift point height (ft)	Load radius (ft)									
	Min.	2	4	6	8	10	12	14	Max.	
GL	14									
	12						1.58			
	10						1.58	1.42	1.39	
	8						1.79	1.70	1.42	1.27
	6					2.71	2.18	1.75	1.40	1.20
	4					3.04	2.21	1.71	1.38	1.17
	2					2.96	2.16	1.68	1.36	1.17
	0				2.46	2.92	2.13	1.66	1.35	1.21
	-2	2.15	1.99	2.73	3.82	2.92	2.12	1.65	1.35	1.30
	-4	3.28	2.77	4.13	4.70	2.94	2.13	1.66		
	-6			5.90	4.55	2.98	2.16			
	-8				2.88	2.07				

Unit=1000 lbs

LIFTING CAPACITY OF (CAB, STEEL TRACK, 6-IN-1 BLADE)

Lifting capacity over-end blade down

Lift point height (ft)	Load radius (ft)									
	Min.	2	4	6	8	10	12	14	Max.	
GL	14									
	12						1.58			
	10						1.58	1.64	1.66	
	8					1.79	1.70	1.66	1.67	
	6				2.71	2.18	1.91	1.75	1.69	
	4				3.56	2.60	2.14	1.87	1.72	
	2				4.13	2.94	2.33	1.98	1.76	
	0				2.46	4.31	3.12	2.45	2.03	1.80
	-2	2.15	1.99	2.73	3.82	4.22	3.13	2.45	1.97	1.84
	-4	3.28	2.77	4.13	5.55	3.90	2.94	2.28		
	-6			5.90	4.55	3.28	2.46			
	-8				2.88	2.07				

Unit=1000 lbs

Lifting capacity over-end blade up

Lift point height (ft)	Load radius (ft)									
	Min.	2	4	6	8	10	12	14	Max.	
GL	14									
	12						1.58			
	10						1.58	1.42	1.38	
	8					1.79	1.70	1.41	1.26	
	6				2.71	2.18	1.75	1.39	1.18	
	4				3.14	2.24	1.72	1.37	1.15	
	2				3.05	2.18	1.68	1.35	1.16	
	0				2.46	3.01	2.15	1.66	1.34	1.20
	-2	2.15	1.99	2.73	3.82	3.01	2.14	1.65	1.34	1.28
	-4	3.28	2.77	4.13	5.05	3.03	2.15	1.66		
	-6			5.90	4.55	3.08	2.19			
	-8				2.88	2.07				

Unit=1000 lbs

Lifting capacity over-side

Lift point height (ft)	Load radius (ft)									
	Min.	2	4	6	8	10	12	14	Max.	
GL	14									
	12						1.58			
	10						1.58	1.38	1.35	
	8					1.79	1.70	1.37	1.23	
	6				2.71	2.18	1.69	1.36	1.16	
	4				2.93	2.13	1.66	1.34	1.13	
	2				2.84	2.08	1.63	1.32	1.13	
	0				2.46	2.81	2.05	1.60	1.31	1.17
	-2	2.15	1.99	2.73	3.82	2.80	2.04	1.60	1.31	1.25
	-4	3.28	2.77	4.13	4.48	2.82	2.05	1.61		
	-6			5.90	4.54	2.87	2.08			
	-8				2.88	2.07				

Unit=1000 lbs



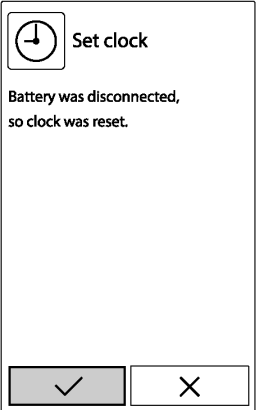
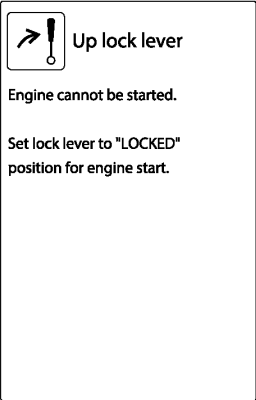

LIST OF SCREENS

NAVIGATION SCREENS

If an error occurs in the machine, one of the following messages appears on the display. In case of trouble, immediately contact your local Kubota dealer for inspection and repair. To view detailed information, press the jog dial (does not apply to numbers 1 through 3). Notify your local Kubota dealer of this information.

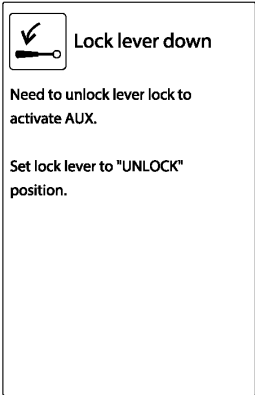
No.	Message	Problem or failure (details)	Machine behavior (provisional measure)	Correction
1	<p>Clock setting request</p>  <p>1SRUU00036B01enUS</p>	<p>The battery is disconnected, thereby requiring to set the clock.</p>	<p>Select “✓” to set the clock.</p>	—
2	<p>Tilt up the lock lever</p>  <p>1SRUU00055B01enUS</p>	<p>This message indicates a procedural step.</p>	<p>Tilt up the pilot control lock lever. This message disappears by tilting up the pilot control lock lever.</p>	—

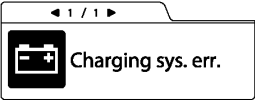
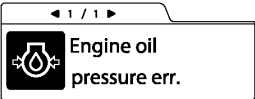
(Continued)

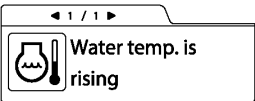
No.	Message	Problem or failure (details)	Machine behavior (provisional measure)	Correction
3	<p>Tilt down the lock lever</p>  <p>1SRUU00059B01enUS</p>	<p>This message indicates a procedural step.</p>	<p>Tilt down the pilot control lock lever. This message disappears by tilting down the pilot control lock lever.</p>	<p>—</p>
4	<p>Out of fuel</p>  <p>1WRRR00072A01enUS</p>	<p>Fuel is running out.</p>	<p>—</p>	<p>Add fuel.</p>
5	<p>Fuel sensor error</p>  <p>1WRRR00075B01enUS</p>	<p>The fuel sensor system is experiencing trouble.</p>	<p>The fuel level indicator does not appear on the meter. The machine's other functions are still operative.</p>	<p>Immediately contact your local Kubota dealer.</p>
6	<p>Charging system error</p>  <p>1WRRR00073A01enUS</p>	<p>Charging system is experiencing trouble. The battery is not charging.</p>	<p>The machine works until the battery goes dead.</p>	<p>Immediately contact your local Kubota dealer.</p>
7	<p>Engine oil pressure error</p>  <p>1WRRR00074A01enUS</p>	<p>The engine lubricating system oil pressure is too low. Stop the engine.</p>	<p>The engine may get burnt out. Immediately stop the engine.</p>	<p>Immediately contact your local Kubota dealer.</p>
8	<p>Overvoltage</p>  <p>1WRRR00088A01enUS</p>	<p>This message appears if a jumper cable is connected to a 24 V battery or improper device to start the engine or if the alternator is experiencing trouble.</p>	<p>Immediately interrupt the engine if with a 24 V battery. When the engine gets restarted and is running with no message appearing, it means there is no problem.</p>	<p>If this message still appears, immediately ask for repairs.</p>
9	<p>Overheat advance warning Water temperature rising</p>  <p>1WRRR00077B01enUS</p>	<p>Water temperature is rising somewhat higher than specified.</p>	<p>Operate with less load. Check the radiator and other components for clog. Immediately clean them up.</p>	<p>—</p>

(Continued)

LIST OF SCREENS

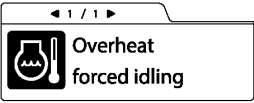
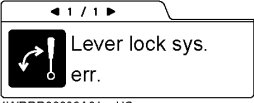
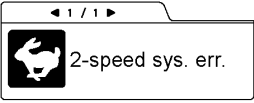
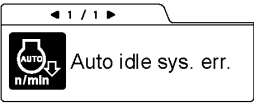
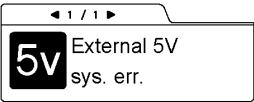
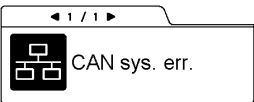
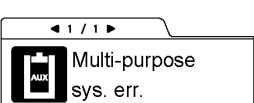
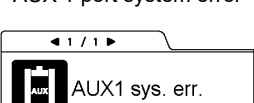

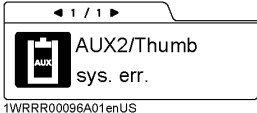
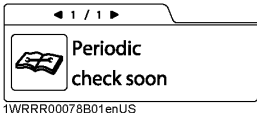
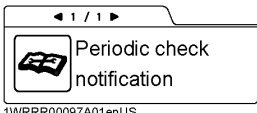
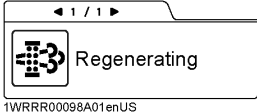
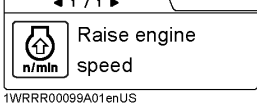
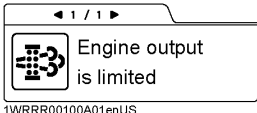
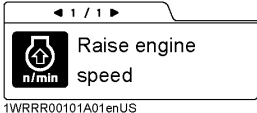

No.	Message	Problem or failure (details)	Machine behavior (provisional measure)	Correction
10	<p>Cool-down during overheat idling</p>  <p>1WRRR00067B01enUS</p>	The engine automatically reduces rpm to avoid an over-heat.	Leave the engine idling until this warning disappears. Do not stop the engine because the coolant temperature will increase sharply and may boil and gush out. Be sure to cool down the engine without stopping it.	Refill the radiator with coolant by the amount that overflowed. Unclog the radiator and other components before using again. Also check the hydraulic system for oil leakage and other troubles. If oil leakage is found, immediately contact your local Kubota dealer for repairs.
11	<p>Lock lever system error</p>  <p>1WRRR00089A01enUS</p>	The lock lever system is experiencing trouble.	The engine can run, but the machine fails to move.	Immediately contact your local Kubota dealer.
12	<p>Travel 2-speed system (switching)</p>  <p>1WRRR00090A01enUS</p>	The 2-speed switching system is experiencing trouble.	The machine still runs at low speed without switching to high speed. The machine's other functions are still operative.	Immediately contact your local Kubota dealer.
13	<p>AI system error</p>  <p>1WRRR00091A01enUS</p>	The Auto Idle system is experiencing trouble. The accelerator fails as well.	The accelerator fails, but the machine's other functions are still operative. Move the machine to a place suitable for repairs.	Immediately contact your local Kubota dealer.
14	<p>5 V short circuit</p>  <p>1WRRR00092A01enUS</p>	The sensor's 5 V power supply has short circuited.	The majority of systems fail. <ul style="list-style-type: none"> The engine may start and the machine may move. However, do not try any operations. Move the machine to a safe place. 	Immediately contact your local Kubota dealer.
15	<p>CAN system error</p>  <p>1WRRR00093A01enUS</p>	The communication (CAN) system is experiencing trouble. Some meter readings may be erroneous or some switches may malfunction.	The engine may start and the machine may move. However do not try any operations. Must move the machine to a safe place.	Immediately contact your local Kubota dealer.
16	<p>General switching system error</p>  <p>1WRRR00094A01enUS</p>	The general switching system is experiencing trouble. This message appears only when the general switching function is preset effective.	The engine can restart and the machine can move, but the general switching system fails. When systems other than the general switching system function, the operation can be continued.	Immediately contact your local Kubota dealer.
17	<p>AUX 1 port system error</p>  <p>1WRRR00095A01enUS</p>	The AUX 1 port system is experiencing trouble.	The engine can restart and the machine can move, but the AUX 1 port system fails. When systems other than the AUX 1 port system function, the operation can be continued.	Immediately contact your local Kubota dealer.

(Continued)



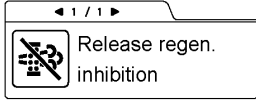
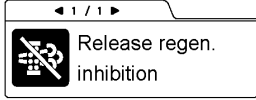
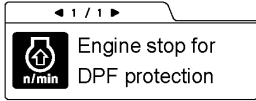

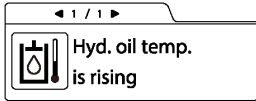
No.	Message	Problem or failure (details)	Machine behavior (provisional measure)	Correction
18	<p>AUX 2/ Thumb system error</p>  <p>AUX2/Thumb sys. err. 1WRRR00096A01enUS</p>	The AUX 2 port system is experiencing trouble.	The engine can restart and the machine can move, but the AUX 2 port system fails. When systems other than the AUX 2 port system function, the operation can be continued.	Immediately contact your local Kubota dealer.
19	<p>Periodic check (advance notice)</p>  <p>Periodic check soon 1WRRR00078B01enUS</p>	This message appears 10 hours before the periodic check interval. The list of related components can be reviewed on the “Periodic check” screen. (See Periodic Check on page 43.)	Start the engine as usual.	Ask your local Kubota dealer for relevant part and replace the existing part with it. After replacement, turn on and off the starter switch 10 times, and this message disappears.
20	<p>Periodic check (warning)</p>  <p>Periodic check notification 1WRRR00097A01enUS</p>	The periodic check interval has passed. The list of related components can be reviewed on the “Periodic check” screen. (See Periodic Check on page 43.)	The engine can still start, but immediately ask your local Kubota dealer for replacement.	Ask your local Kubota dealer for relevant part and replace the existing part with it. After replacement, turn on and off the starter switch 10 times, and this message disappears.
21	<p>Exhaust temp rise Operate carefully possible to work</p>  <p>Regenerating 1WRRR00098A01enUS</p>	For the process of DPF regeneration, the exhaust gas temperature rises. It is possible to work with careful operation.	—	—
22	<p>Raise engine speed</p>  <p>Raise engine speed 1WRRR00099A01enUS</p>	The DPF must be regenerated.	For low engine rpm, the machine cannot start DPF regeneration.	Rev up the engine rpm and start the diesel-particulate-filter (DPF) regeneration.
23	<p>Now HP is limited</p>  <p>Engine output is limited 1WRRR00100A01enUS</p>	For the process of DPF regeneration, the exhaust gas temperature rises. It is possible to work with careful operation.	To protect the DPF, engine output is limited.	—
24	<p>Raise engine speed Now HP is limited</p>  <p>Raise engine speed 1WRRR00101A01enUS</p>	The DPF is clogged. The DPF must be regenerated.	The diesel-particulate-filter (DPF) must be regenerated, but low engine rpm is unable to start the diesel-particulate-filter (DPF) regeneration. To protect the DPF, engine output is limited. If you leave the machine with the hydraulic locked, the engine can stop automatically.	Rev up the engine rpm and start DPF regeneration. If this message still appears, immediately contact your local Kubota dealer.

(Continued)

LIST OF SCREENS

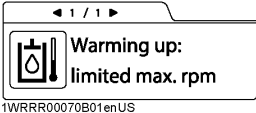
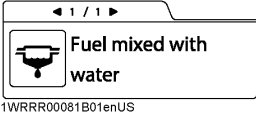
No.	Message	Problem or failure (details)	Machine behavior (provisional measure)	Correction
25	<p>Regen.inhibition. Release it.</p>  <p>1WRRR00102A01enUS</p>	The DPF must be regenerated.	The DPF must be regenerated, but unable to start regeneration because the inhibited switch is activated.	Move the machine to a safe place and release the inhibit switch to start DPF regeneration. If this message still appears, immediately contact your local Kubota dealer.
26	<p>Regen. inhibition. Release it. Now HP limited</p>  <p>1WRRR00103A01enUS</p>	The DPF is clogged. The DPF must be regenerated.	The DPF must be regenerated, but unable to start regeneration because the inhibited switch is activated. If you leave the machine with the hydraulic locked, the engine can stop automatically.	Move the machine to a safe place and release the inhibit switch to start DPF regeneration. If this message still appears, immediately contact your local Kubota dealer.
27	<p>Warning-stop engine. Rev up and restart.</p>  <p>1WRRR00104A01enUS</p>	To protect the DPF, the engine stopped automatically.	—	Turn off the starter switch and restart the engine. Move the machine to a safe place immediately and rev up the engine rpm to start the DPF regeneration.
28	<p>The DPF is clogged up. Need repairing</p>  <p>1WRRR00105A01enUS</p>	The machine can not start DPF regeneration.	DPF must be repaired.	Immediately contact your local Kubota dealer.
29	<p>Exchange the DPF.</p>  <p>1WRRR00106A01enUS</p>	The machine can not start DPF regeneration.	DPF must be replaced.	Immediately contact your local Kubota dealer.
30	<p>Overheat advance warning Hydraulic oil temperature rising</p>  <p>1WRRR00068B01enUS</p>	Hydraulic oil temperature is rising somewhat higher than specified.	Operate with the load a little lessened.	—
31	<p>Overheat advance warning Auto idling for the temperature of the hydraulic oil rising</p>  <p>1WRRR00069B01enUS</p>	The engine was forced to idle because the hydraulic oil temperature had risen too high.	Leave the engine idling until the overheat advance warning disappears. Do not stop the engine because the temperature of the hydraulic oil will increase sharply. Be sure to cool down the engine without stopping it.	Unclog the oil cooler and other components before using again. Check also the hydraulic system for oil leak and other troubles. If an oil leak is found, immediately contact your local Kubota dealer for repair.

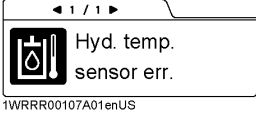
(Continued)

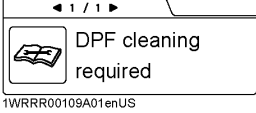
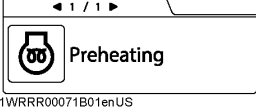
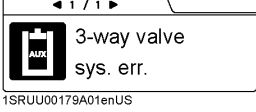
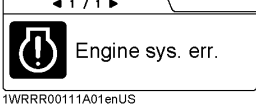
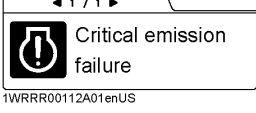
No.	Message	Problem or failure (details)	Machine behavior (provisional measure)	Correction
32	<p>Warming-up</p>  <p>1WRRR00070B01enUS</p>	<p>No warm-up operation was made. The engine was revved up only to the medium rpm because the hydraulic oil temperature had dropped too low.</p>	Warm up the engine.	—
33	<p>Water got mixed with fuel</p>  <p>1WRRR00081B01enUS</p>	Water is in the fuel filter and water may be in the fuel filter.	If you do not drain the fuel filter immediately after the alarm, the engine may be seriously damaged.	Immediately drain the fuel filter after stopping the engine and drain the water separator as soon as possible.
34	<p>Stop button is activated</p>  <p>1WRRR00087A01enUS</p>	The engine cannot be started.	—	Press the engine stop button before starting engine.
35	<p>Hyd. temp. sensor err.</p>  <p>1WRRR00107A01enUS</p>	The hydraulic oil temperature sensor system is experiencing trouble.	Meter does not show the hydraulic oil temperature, and overheating cannot be detected.	Immediately contact your local Kubota dealer.
36	<p>DPF cleaning soon</p>  <p>1WRRR00108A01enUS</p>	The DPF will need cleaning soon.	Operate the machine as usual.	Contact your local Kubota dealer to have the DPF cleaned.
37	<p>DPF cleaning required</p>  <p>1WRRR00109A01enUS</p>	The DPF needs cleaning.	The engine can still start, but you must immediately contact your local Kubota dealer for cleaning.	Contact your local Kubota dealer to have the DPF cleaned.
38	<p>Preheating</p>  <p>1WRRR00071B01enUS</p>	The engine is preheating.	—	Wait until this message disappears, and then start engine.
39	<p>3-way valve sys. err.</p>  <p>1SRUU00179A01enUS</p>	The one-way or two-way selection valve system is experiencing trouble.	If systems other than one-way or two-way selection valve system function, work can be continued.	Immediately contact your local Kubota dealer.
40	<p>Engine sys. err.</p>  <p>1WRRR00111A01enUS</p>	The engine system is experiencing trouble.	—	Immediately contact your local Kubota dealer.
41	<p>Critical emission failure</p>  <p>1WRRR00112A01enUS</p>	The particulate control device (PCD) / NOx control device (NCD) is experiencing trouble.	Engine control is not working properly.	Immediately contact your local Kubota dealer for emergency repairs.

(Continued)

LIST OF SCREENS

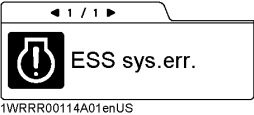
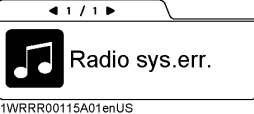
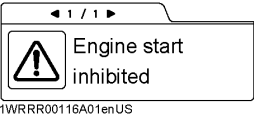
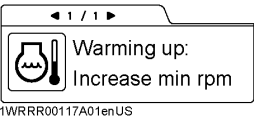









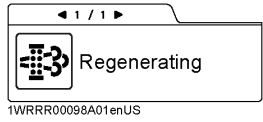

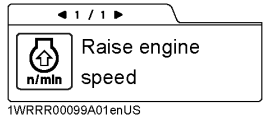
No.	Message	Problem or failure (details)	Machine behavior (provisional measure)	Correction
42	 <p>Dozer tilt sys.err. 1WRRR00113A01enUS</p>	<p>Problem with dozer tilt system. Malfunction: Dozer tilt knob (short circuit)</p> <p>Problem with dozer tilt system. Malfunction: Dozer tilt knob (open circuit)</p> <p>Problem with dozer tilt system. Malfunction: Tilt-R or L solenoid (open circuit)</p>	<p>If systems other than dozer tilt system function, work can be continued.</p>	<p>Immediately contact your local Kubota dealer.</p>
43	 <p>ESS sys.err. 1WRRR00114A01enUS</p>	<p>Problem with ESS system. Malfunction: ESS solenoid (open circuit)</p>	<p>If systems other than ESS system function, work can be continued.</p>	<p>Immediately contact your local Kubota dealer.</p>
44	 <p>Radio sys.err. 1WRRR00115A01enUS</p>	<p>Problem with radio system. Malfunction: radio</p>	<p>If systems other than radio system function, work can be continued.</p>	<p>Immediately contact your local Kubota dealer.</p>
45	 <p>Engine start inhibited 1WRRR00116A01enUS</p>	<p>Machine start is disabled by Kubota NOW.</p>	<p>—</p>	<p>Immediately contact your local Kubota dealer.</p>
46	 <p>Warming up: Increase min rpm 1WRRR00117A01enUS</p>	<p>Coolant temp. is too low. Engine is revved up for warming-up.</p>	<p>—</p>	<p>—</p>

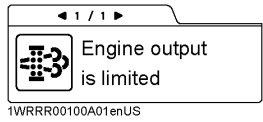
AUTOMATIC DIESEL PARTICULATE FILTER (DPF) REGENERATION

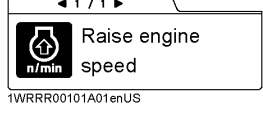
Automatic regeneration is a normal maintenance activity that a machine performs automatically.

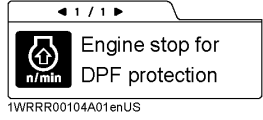
The diesel particulate filter (DPF) serves to trap particulate matters (PM) that are contained in exhaust gases and to automatically burn (DPF-regenerate) these matters. During the regeneration, buzzer sounds and warning lamp blinks and display shows messages.

The following is an explanation and required operator action.

Warning lamp	Display	Meaning	Required operator action
 Blinking (yellow)		Auto regeneration starts. Continue operating the machine.	Operate the machine until the warning lamp stops blinking. Make sure that no people, animals, plants and flammable materials are within the immediate working area.
 Blinking (yellow)		When the message "Raise engine speed" appears on the display, raise the engine speed until the message disappears.	Increase the engine speed until the message "Raise engine speed" disappears. Auto regeneration starts. Operate the machine until the warning lamp stops blinking. Make sure that no people, animals, plants and flammable materials are within the immediate working area. (Refer to No. 22 in Navigation list of screens section.)
 Blinking (yellow)		The DPF is in the regeneration process but the engine output is limited.	Keep raising the engine speed and finish the DPF regeneration process. Make sure that no people, animals, plants and flammable materials are within the immediate working area.
 Blinking (red)		The DPF is clogged. Start the DPF regeneration immediately. To protect the DPF, the engine output is limited. When the pilot control lock lever is pulled up, the engine will stop after 60 seconds in order to protect DPF. When the pilot control lock lever is down, the engine will not stop while the engine output is limited.	Increase the engine speed until the message "Raise engine speed" disappears. Auto regeneration starts. Make sure that no people, animals, plants and flammable materials are within the immediate working area. (Refer to No. 24 in Navigation list of screens section.)
 Blinking (red)		To protect the DPF, the engine stopped automatically.	Restart the engine and raise its speed until the machine starts DPF regeneration. Unless the auto regeneration starts, contact your local Kubota dealer.
 Blinking (red)		DPF must be repaired. To protect the DPF, the engine output is limited. When the pilot control lock lever is pulled up, the engine will stop after 60 seconds in order to protect DPF. When the pilot control lock lever is down, the engine will not stop while the engine output is limited.	Immediately contact your local Kubota dealer. (Refer to No. 28 in Navigation list of screens section.)
 Blinking (red)		Exchange the DPF. To protect the DPF, the engine output is limited.	Immediately contact your local Kubota dealer. (Refer to No. 29 in Navigation list of screens section.)

NOTE :

- Stopping the engine or pressing the inhibit switch during the automatic regeneration cycle stops the automatic regeneration process.
After restarting the engine, automatic regeneration starts.

- Regeneration time is approximately 20 to 30 minutes, and the interval is approximately 50 to 60 hours. But actual regeneration time and interval depend on usage environment like ambient temperature, exhaust temperature and engine speed.

LOCKING AND RELEASING THE DIESEL PARTICULATE FILTER (DPF) REGENERATION

1. Press the inhibit switch (1).

The automatic DPF regeneration is locked and the inhibit lamp on the display lights up.

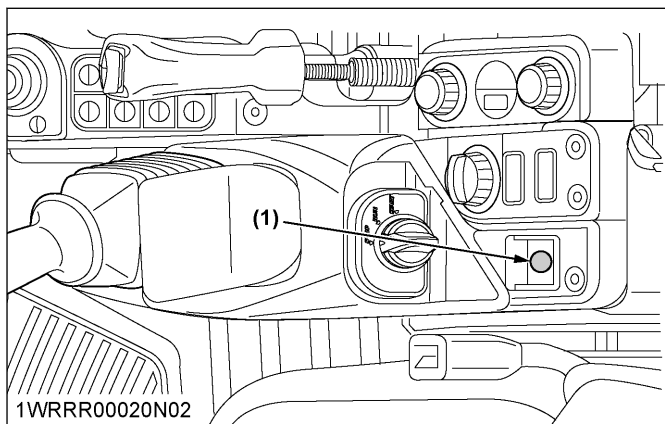



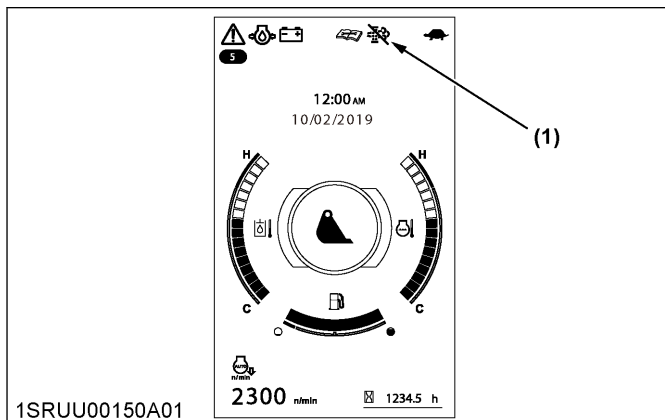









(1) Inhibit switch

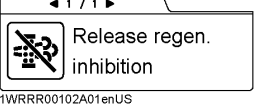

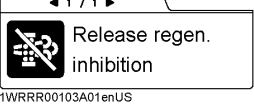
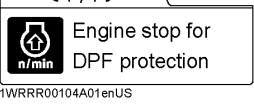
(1) Inhibit lamp

LIST OF SCREENS

2. Take the appropriate action based on the following table.

Inhibit lamp	Warning lamp	Display	Meaning	Required operator action
 Lights up (yellow)	 Unlit	—	<ul style="list-style-type: none"> Auto regeneration process is locked. The state is before requirement of regeneration. When inhibit switch turns into blinking, it requires regeneration. 	<ul style="list-style-type: none"> Operate the machine as usual.
 Blinking (yellow)	 Blinking (yellow)		<ul style="list-style-type: none"> Auto regeneration process is locked. Operator needs preparation of DPF regeneration. 	<ul style="list-style-type: none"> Move the machine to a safe place and release the inhibit switch. Increase the engine speed until the machine starts DPF regeneration. Make sure that no people, animals, plants and flammable materials are within the immediate working area. (Refer to No. 25 in Navigation list of screens section.)
 Blinking (yellow)	 Blinking (red)	 	<ul style="list-style-type: none"> Auto regeneration process is locked. Operator needs to prepare for DPF regeneration immediately. The DPF is clogged. To protect the DPF, engine output is limited. When the pilot control lock lever is raised up, the engine will stop after 60 seconds in order to protect DPF. When the Pilot control lock lever is down, the engine will not stop while the engine output is limited. 	<ul style="list-style-type: none"> Move the machine to a safe place and release the inhibit switch. Increase the engine speed until the machine starts DPF regeneration. Make sure that no people, animals, plants and flammable materials are within the immediate working area. (Refer to No. 26 and 27 in Navigation list of screens section.)
 Blinking (yellow)	 Blinking (red)		<ul style="list-style-type: none"> DPF must be repaired. To protect the DPF, engine output is limited. When the pilot control lock lever is raised up, the engine will stop after 60 seconds in order to protect DPF. When the Pilot control lock lever is down, the engine will not stop while the engine output is limited. 	<p>Immediately contact your local Kubota dealer. (Refer to No. 28 in Navigation list of screens section.)</p>
 Blinking (yellow)	 Blinking (red)		<ul style="list-style-type: none"> DPF must be exchanged. To protect the DPF, engine output is limited. 	<p>Immediately contact your local Kubota dealer. (Refer to No. 29 in Navigation list of screens section.)</p>

SOFTWARE INFORMATION

- This product includes “*Open Source Software*” (OSS).
- You must read and accept the terms and conditions of each license (OSS license).
- This product includes OSS that is made available under the “GNU Lesser General Public License” (LGPL).
- If you have purchased this product, you may reverse engineer the OSS to the extent that such OSS licenses are applied but only when you need to do so to use this software.
- This product includes OSS that is made available under the “*GNU General Public License*” (GPL), LGPL, or the “*Mozilla Public License 2.0*” (MPL).
- If you purchase this product, you may obtain, copy, modify and distribute the applicable source code under the OSS licenses.
- The OSS license and source code is available at the following URL:
<https://www.kubota.com/products/opensource/index.html>

Disclaimer

This product includes “*Open Source Software*”, which is provided “*as is*”.

Kubota and any third party that has the right to use OSS shall not be liable for any damages arising out of this software and its use or the inability to use it.

INDEX

Symbols

6-in-1 blade operating.....	101
--------------------------------	-----

A

after working in cold weather.....	158
air conditioner	
adjusting air flow.....	74
cooling.....	75
defrosting.....	75
dehumidifying-heating.....	75
demisting.....	75
heating.....	75
air conditioner belt tension [CAB type only]	
adjusting.....	136
checking.....	136
air conditioner condenser	
checking.....	135
air conditioner control panel.....	75
air conditioner filter	
cleaning.....	131
air conditioner hose	
checking.....	144
replacing.....	145
air conditioner operation.....	75
air conditioner pipe	
checking.....	144
replacing.....	145
air filter element	
cleaning.....	133
inspecting.....	133
replacing.....	144
air flow	
adjusting.....	74
air outlet (front).....	74
alternator	
checking.....	144
AM mode	
operating.....	57
angle blade	
operating.....	101
arm	
operating.....	91
audio	
switching power on and off.....	55
audio screen.....	54
audio source	
switching.....	56
audio volume	
adjusting.....	56
auto idle (AI) control	
operating.....	103

auto idle (AI) control switch	
checking.....	65
automatic diesel particulate filter (DPF) regeneration.....	187
AUX port enable switch	
checking.....	65
auxiliary port	
operating.....	94
releasing pressure.....	100
selecting operation mode.....	93
setting maximum flow volume.....	97
using the one-way hold.....	96
auxiliary port operation.....	92
auxiliary valve filter	
cleaning.....	143

B

battery	
charging.....	130
checking condition.....	129
handling.....	13
beacon light switch.....	67
biodiesel fuel (BDF).....	163
bluetooth microphone.....	76
Bluetooth mode	
operating.....	59
boom	
operating.....	90
boom lowering valve	
operating.....	103
boom swing	
operating.....	92
boost sensor and AFS (air flow sensor)	
checking.....	145
breather filter	
replacing.....	139
bucket	
changing (warning information).....	153
operating.....	91

C

CAB door	
closing.....	72
opening.....	72
CAB front window door	
closing.....	72
opening.....	72
CAB side window	
closing.....	73
opening.....	73
call control	
Bluetooth-connected cell phone.....	62

clamps	
checking.....	132
clock	
reordering year/month/day.....	48
selecting 24-hour system.....	48
selecting AM/PM system.....	48
setting.....	46
condition of the diesel particulate filter (DPF) muffler	
checking.....	145
coolant level	
checking.....	120
coolant temperature gauge	
checking.....	41
CRS diesel engine	
fuel use.....	165
maintenance.....	165
cup holder.....	119

D

daily check	
checking and cleaning electrical wiring.....	125
checking and cleaning engine.....	125
checking coolant level.....	120
checking engine oil level.....	121
checking fuel level.....	121
checking hydraulic oil level.....	122
checking oil cooler.....	123
checking radiator.....	123
checking washer liquid.....	125
daily check (warning information).....	120
dealer service.....	31
diesel particulate filter (DPF)	
cleaning.....	149
diesel particulate filter (DPF) differential pressure sensor and piping for gas leaks	
checking.....	145
diesel particulate filter (DPF) differential pressure sensor rubber piping (front and back)	
replacing.....	148
diesel particulate filter (DPF) exhaust gas temperature sensor	
checking.....	145
diesel particulate filter (DPF) muffler	
checking.....	125
diesel particulate filter (DPF) regeneration	
locking.....	189
releasing.....	189
display brightness	
setting.....	48
dozer	
operating.....	90
DPF regeneration.....	84
drive lever (right, left)	
operating.....	87
drive unit oil	
changing.....	139

E

EGR cooler	
checking.....	144
EGR cooler hose	
replacing.....	148
EGR piping for gas leaks	
checking.....	145
EGR system	
checking.....	144
electrical equipment	
checking.....	126
electrical outlet.....	67
electrical wiring	
checking.....	125,144
cleaning.....	125
emergency hammer.....	73
engine	
check points after starting the engine.....	82
operating.....	79
starting.....	79
starting under cold conditions.....	81
starting with an auxiliary battery.....	82
stopping.....	83
engine and electrical wiring	
checking.....	125
cleaning.....	125
engine auto-stop function	
setting.....	49
engine hood	
closing.....	118
opening.....	118
engine oil	
changing.....	137
engine oil filter cartridge	
replacing.....	138
engine oil level	
checking.....	121
engine stop button.....	83
engine tachometer	
checking.....	43
engine valve clearance	
checking.....	143
error warning	
checking.....	64
evacuator valve	
checking.....	125
cleaning.....	134
excavator	
driving instructions.....	86
lifting (warning information).....	107
scrapping procedure.....	32
towing.....	106
transporting on truck.....	105
warranty policy.....	31
excavator main dimensions.....	166
excavator parts.....	35

exhaust leaks	
checking.....	126
exhaust manifold (cracks, gas leakage, and mounting screw)	
checking.....	145

F

fan belt tension	
adjusting.....	136
checking.....	136
FCC Statement.....	77
filter indicator	
checking.....	124
fire prevention.....	15
FM mode	
operating.....	58
front attachment	
greasing.....	126
front idler oil	
changing.....	144
front window base	
removing.....	73
fuel filter cartridge	
replacing.....	139
fuel gauge	
checking.....	40
fuel hose	
replacing.....	147
fuel hose clamp	
replacing.....	147
fuel level	
checking.....	121
fuel level audible indication switch (when refueling)	
checking.....	41
fuel line	
checking.....	134
fuel system	
purging.....	150
fuel tank	
draining water.....	129
fuel tank cover	
closing.....	118
opening.....	118
fuels (recommended).....	161
fuses	
checking.....	144
replacing.....	153

G

glow indication	
checking.....	43
grease gun	
storing.....	119

H

hands-free phone	
impact of Bluetooth.....	76
heat-up function	
setting.....	53
heater switch.....	71
high-pressure fuel system	
handling.....	15
horn switch.....	64
hour meter	
checking.....	43
hydraulic components	
handling.....	14
hydraulic hose	
replacing.....	148
hydraulic oil	
changing.....	141
hydraulic oil (hydraulic hammer operation)	
checking.....	143
hydraulic oil level	
checking.....	122
hydraulic oil overheat warning	
checking.....	42
hydraulic oil temperature gauge	
checking.....	42
hydraulic pilot filter element	
replacing.....	140
hydraulic return filter element	
replacing.....	141
hydraulic system	
releasing pressure.....	100
hydraulic tank selection valve	
selecting circuit	102

I

inhibit diesel particulate filter (DPF) regeneration switch	
.....	67
injector tip	
checking.....	144
instrument panel.....	37
intake air line	
checking.....	134
replacing.....	147
intake air line for air leaks	
checking.....	145
interior lamp.....	71
ISED Canada Statement.....	78

K

keyless start	
changing the machine password.....	53
changing user passwords.....	51
deleting user passwords.....	52
registering new user passwords.....	50

L

levers (control).....	69
lifting capacity	
CAB, rubber track, 6-in-1 blade.....	178
CAB, rubber track, angle blade.....	176
CAB, rubber track, standard blade.....	174
CAB, steel track, 6-in-1 blade.....	179
CAB, steel track, angle blade.....	177
CAB, steel track, standard blade.....	175
canopy, rubber track, 6-in-1 blade.....	172
canopy, rubber track, angle blade.....	170
canopy, rubber track, standard blade.....	168
canopy, steel track, 6-in-1 blade.....	173
canopy, steel track, angle blade.....	171
canopy, steel track, standard blade.....	169
lifting capacity (important information).....	167
lighting for night operation.....	65

M

machine	
lifting (basic points).....	107
lifting (safety aspects).....	107
lifting procedure.....	107
operating (after long-term storage).....	159
parking on slope (warning information).....	89
precautions when washing.....	110
storing.....	159
technical data.....	33
working (safety).....	9
machine operation	
important information.....	104
maintenance intervals.....	111
maintenance intervals (air conditioner).....	117
maintenance work (warning information).....	129

N

new machine	
operating.....	85

O

oil cooler	
checking.....	123
oils (recommended).....	161
one-way circuit selection valve.....	102
operating record	
checking.....	46
operation	
pivoting.....	88
spinning.....	89
traveling downhill.....	89
traveling uphill.....	89
operator's manual	
storing.....	120
overheat warning	
checking.....	42

overheating countermeasures.....	83
----------------------------------	----

P

parts (periodic replacement).....	159
pattern selection system	
changing pattern.....	90
pedals (control).....	69
periodic check interval message	
setting.....	43
pilot control lock lever	
handling.....	70
starting operation.....	86
pilot line filter	
cleaning.....	143
pilot valve linkage	
greasing.....	137
plastic parts	
cleaning.....	149
preparation for work in cold weather.....	158

Q

quantity of refrigerant (gas)	
checking.....	148

R

radiator	
checking.....	123
handling.....	14
radiator coolant	
changing.....	146
radiator hose	
replacing.....	145
radiator hose clamp	
replacing.....	145
radiator hoses	
checking.....	132
regular checks (warning information).....	129
ROPS	
checking.....	124
rubber track	
adjusting.....	151

S

safety	
avoiding crystalline silica (quartz) dust.....	10
fire prevention.....	15
general information.....	7
handling the battery.....	13
handling the high-pressure fuel system.....	15
handling the hydraulic components.....	14
Handling the radiator.....	14
loading the machine.....	11
OPG.....	8
post-operation.....	11

precautions when performing checks or maintenance.....	12
precautions when using the front attachments to lift the machine.....	15
ROPS.....	8
starting to operate the machine.....	9
transporting the machine.....	11
waste material.....	15
working the machine.....	9
safety for children.....	10
safety labels	
taking care of the labels.....	29
safety labels (danger, warning and caution).....	17
screens (navigation) list.....	180
seat (operator's)	
adjusting.....	85
seat belt	
checking.....	126
service hour meter	
checking.....	45
side cover	
closing.....	119
opening.....	119
slow blow fuse	
replacing.....	154
software information.....	191
special information regarding the use rubber tracks.	152
starter motor	
checking.....	144
starter switch	
checking.....	40
steel track	
adjusting.....	150
suction filter	
replacing.....	141
suction pipe downstream the AFS (air flow sensor)	
replacing.....	148
switches.....	37
swivel	
operating.....	92
swivel bearing	
greasing.....	133
swivel bearing teeth	
greasing.....	131
synthetic leather	
cleaning.....	149
T	
temperature drop indication of hydraulic oil	
checking.....	43
throttle potentiometer	
checking.....	66
tools	
storing.....	119
track	
check.....	131

track roller oil	
changing.....	144
travel speed switch	
checking.....	66
troubleshooting.....	156
turbo charger	
checking.....	144
two-way circuit selection valve.....	102

U

USB outlet.....	67
user setting	
checking the operating record.....	46
setting periodic check interval message.....	43
user settings.....	46
using the seat belt.....	85

V

V-belt	
checking.....	125
V-belt tension	
adjusting.....	136

W

walk-around inspection.....	120
warning (battery charge).....	63
warning (low engine oil pressure).....	63
warning (remaining fuel).....	63
warning (various errors).....	64
warning lamp	
checking.....	63
warranty policy.....	31
washer liquid	
checking.....	125
water separator	
checking.....	123
cleaning water.....	129
draining.....	149
draining water.....	129
water separator filter element	
replacing.....	137
weather band mode	
operating.....	60
wiper	
operating.....	71
work light turn-off delay function	
setting.....	50
working light switch	
operating.....	64